

*Guide Book*

**REFRESHER COURSE**

*for*

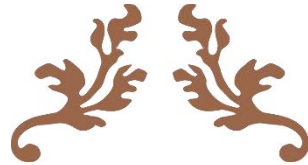
**Certified Energy  
Managers and Auditors**



**Bureau of Energy Efficiency**  
Ministry of Power,  
Govt. of India  
4th Floor, Sewa Bhawan,  
R. K. Puram, New Delhi - 110066



# *Guide Book*



---

## REFRESHER COURSE

*for*

### Certified Energy Managers and Auditors

---

**2018**



**Bureau of Energy Efficiency**  
**Ministry of Power,**  
**Govt. of India**  
**4th Floor, Sewa Bhawan**  
**R. K. Puram, New Delhi - 110066 (INDIA)**

**Prepared by**

National Productivity Council, India

---

**Copyright © Bureau of Energy Efficiency 2018**

All rights reserved. All information contained in this publication is copyrighted, and as such no part of this publication may be reproduced or utilized in any form or by any other means, electronic or mechanical, including photocopying, or by any information storage and retrieval system, without permission in writing from the publishers.

**CORE TEAM**

<b>PRINCIPAL EDITOR (NPC)</b>	Mr. R. Suryanarayanan Director, National Productivity Council (NPC)
<b>REVIEW GROUP (BEE)</b>	Mr. Abhay Bakre Director General Bureau of Energy Efficiency
	Mr. Pankaj Kumar Secretary Bureau of Energy Efficiency
	Mr. Saurabh Diddi Director Bureau of Energy Efficiency
	Dr. Ashok Kumar Director Bureau of Energy Efficiency
	Mr. S. K. Khandare Director Bureau of Energy Efficiency
	Mr. Sameer Pandita Director Bureau of Energy Efficiency
	Ms. Rajini Thompson Coordinator (Exam) Bureau of Energy Efficiency
<b>ADVISORY INPUTS (NPC)</b>	Mr. K.V.R. Raju Regional Director, National Productivity Council (NPC)

## EXTERNAL CONTRIBUTORS & REVIEWERS

---

Mr. Padu S Padmanabhan Strategic Energy, Water, Environment Expert	Mr. R.K. Khilnani, Managing Director, Energy Tech Consultants Pvt. Ltd	A. M Narayanan Head - Energy Efficiency Energy Management Centre-Kerala	J. Nagesh Kumar Director , CEEP And former Director (NPC, Chennai)
Mr. T. Sankaranarayanan Energy Consultant (Former Regional Director (NPC, Mumbai)	Mr. P. Dharmalingam ENSAVE Consultancy and Training Pvt. Ltd. Former Regional Director (NPC, Chennai)	Mr. H. Ragavendra Prabhu Director & Head, NPC, Bengaluru	Dr. P. Kanagavel Additional Director & Head, National Institute of Wind Energy (NIWE), MNRE
Mr. S. Srinivas, Deputy Exec. Director (IGBC) CII- Sohrabji Godrej Green Business Centre	Mr. R. Kumar, Director - Energy & Sustainability, Jones Lang LaSalle	Mr. V.S. Deshpande Head – Sales & Marketing (Div-T2) Transparent Cogen Systems Pvt. Ltd., Pune	Dr. Anant Shukla ASEAN-German Energy Programme (AGEP) Senior Advisor Deutsche Gesellschaft für, Internationale Zusammenarbeit (GIZ) GmbH, Indonesia
Dr. Satyanarayan Seshadri CTO, Aspiration Energy	Deepak Gokhale General Manager Corporate Technical and Energy Services Aditya Birla Management Corporation Pvt. Ltd.		

---

## NPC CONTRIBUTORS

---

Mr.. Suryanarayanan Director (Energy) NPC, Chennai	Mr. Sreenivasulu Deverapalli Sr. Dy. Director (Env.) NPC, Chennai	Mr. Joel Franklin Asaria, Deputy Director, NPC, Chennai	Ms. P. Chitra Dy. Director NPC, Chennai
Mr. Velayutham V Dy. Director, NPC, Chennai	Mr. J. P. Varun, Asst. Director, NPC, Chennai	Mr. Idhayachander Ravichandran Dy. Director, NPC, Chennai	Ms. V G. Sandhya Assistant Director NPC, Chennai

---



## PREFACE

Most of the energy managers/auditors, who qualified way back, may not have kept pace with the advancements in the field of energy. Furthermore, Gazette states that certificate issued on successful completion of Energy Manager/Energy Auditor exam is valid for only *five years* with the effect from the date of the award and is renewable only on attending a refresher course.

Accordingly, refresher course was proposed and the topics for coverage were finalized after several rounds of meeting by the expert groups and in line with the requirements of the Bureau of Energy Efficiency. The course material is prepared by National Productivity Council after taking into account the latest developments and advancements such as renewable energy, smart grid, smart cities, ISO 50001 (2018 version), measurement & verification, carbon footprint, energy efficient buildings and so on.

The training based on refresher course material is expected to boost self-confidence and skill-set of the energy managers/energy auditors. It is designed to improve their energy management and auditing skills and boost their confidence and motivate them to take up challenging assignments.





## ACRONYMS

AAC	Autoclaved Aerated Concrete
AMI	Advanced Metering Infrastructure
AT&C	Aggregate Technical & Commercial
BAT	Best Available Technology
BEE	Bureau of Energy Efficiency
BEMS	Building Energy Management System
BIPV	Building integrated photovoltaic
BM	Building Management
BoS	Balance of System
BP	British Petroleum
BPO	Business Process Outsourcing
CAES	Compressed air energy storage
CAPEX	Capital Expenditure
CBM	Coal Bed Methane
CCF	Closed Cavity Facades
CCHP	Combined Cooling, Heating, and Power
CdTe	Cadmium telluride
CEEDR	Centralized Energy Efficiency Data Repository
CERC	Central Electricity Regulatory Commission
CFL	Compact Fluorescent Light
CIGS	Copper Indium Gallium selenide/sulphide
COP	Conference of the Parties (UNFCCC)
COP	Coefficient of Performance
CPP	Captive Power Plant
CPS	Cyber-physical systems
CPV	Concentrator Photovoltaic or Concentrating Photovoltaic
CRI	Colour Rendering Index
CSR	Corporate Sustainability Reporting
DC	Designated Consumer
DCV	Demand-Controlled Ventilation
DGUs	Double-glazed units
DHI	Diffuse Horizontal Irradiation
DISCOM	Distribution Service Company
DNI	Direct Normal Irradiation
DX	Distributed System
EC	Electronically commutated (fans)
ECBC	Energy Conservation Building Code
ECM	Energy Conservation Measure
EE	Energy Efficiency
EEM	Energy Efficiency Measure
EER	Energy Efficiency Ratio
EIMAS	Energy Information Management Analytic System
EmAEA	Empaneled Accredited Energy Auditor
EnBIs	Energy Baselines
EnPIs	Energy Performance Indexes
EP	Environmental Protection
EPC	Engineering, Procurement and Construction
EPI	Energy Performance Index
EPS	Expanded polystyrene

ESCerts	Energy Saving Certificates
ESCO	Energy Service Company
ETC	Evacuated Tube Collectors
FIT	Feed-in Tariff
FPC	Flat Plate Collectors
GAP	Gap analysis
GDP	Gross Domestic Product
GHG	Greenhouse gases
GHI	Global Horizontal Irradiation
GRIHA	Green Rating for Integrated Habitat Assessment
GTKM	Gross Tonne Kilometers (It is total weigh of locomotives and vehicles)
HAN	Home Area Network
HRV	Heat recovery ventilation
IEA	International Energy Agency
IEC	International Electrotechnical Commission
IEX	Indian Energy Exchange
IGBC	Indian Green Building Council
INDC	Intended Nationally Determined Contribution
IoT	Internet of things
KPIs	Key Performance Indexes
LED	Light Emitting Diode
LEED	Leadership in Energy and Environmental Design
LiBr	Lithium Bromide
LNG	Liquefied Natural Gas
LPD	Lighting Power Density
LPD	Litres per day
LPF	Litres per Flush
LSG	Light to Solar Gain Ratio
M&V	Measurement & Verification
MBN	Parameter for monitoring the Energy Performance of Refinery
MEG	Micro energy grid (MEG)
MEMS	Micro-Electro-Mechanical-Systems
MEPS	Minimum Energy Performance Standards
MJ	Mega Joule
MNRE	Ministry of New and Renewable Energy
MTOE	Million tonnes oil equivalent
MW	Megawatt
NABERS	National Australian Built Environment Rating System
NBC	National Building Code
NMEE	National Mission on Enhanced Energy Efficiency
NZEB	Net Zero Energy Building
ORC	Organic Rankine Cycle
Pa	Pascal
PAT	Perform Achieve Trade
PDCA	Plan Do Check Act
PDEC	Passive downdraft evaporative cooling
PE cells	Photoelectric cells
PLF	Plant Load Factor
PMU	Phasor Measurement Units
POSCO	Power System Operation Corporation Limited
PPA	Power Purchase Agreement
PPP	Purchase Power Parity

PRDS	Pressure Reducing and DeSuperheating System ...
PRV	Pressure Reducing Valve
PTC	Parabolic Trough Collector
PTPP	Parabolic Trough Power Plant
PV	Photovoltaic
PXIL	Power Exchange of India
R/P	Reserve to Production ratio
R-APDRP	Restructured Accelerated Power Development and Reforms Programme
REC	Renewable Energy Certificate
RESCO	Renewable Energy Service Company
R-LNG	Re-gasified Liquid Natural Gas
RPO	Renewable Purchase Obligation
S&L	Standard & Labeling
SDA	State Designated Agency
SEC	Specific Energy Consumption
SECI	\Solar Energy Corporation of India Limited
SERC	State Electricity Regulatory Commission (SERC) regulations
SEUs	Significant Energy Uses
SHGC	Solar Heat Gain Coefficient
T&D	Transmission & Distribution
TFC	Total Final Consumption
TOE	Tonnes oil equivalent
Toe	Tonne oil equivalent
U value	Denotes conduction heat loss
UNFCC	United Nations Framework Convention on Climate Change
USEPA	US Environmental Protection Agency
USGBC	US Green Building Council
VAM	Vapour Absorption Machine
VAV	Variable Air Volume
VFD	Variable Frequency Drive
VLT	Visual Light Transmission
WBP	Whole Building Performance
WWR	Window-to-wall ratio
XPS	Extruded polystyrene



# TABLE OF CONTENTS

		<i>Page no.</i>
	PREFACE	VII
	ACRONYMS	IX
<b>1.</b>	<b>ENERGY SCENARIO UPDATES</b>	<b>1</b>
1.1	Introduction	1
1.2	Coal	3
1.3	Oil	4
1.4	Natural Gas	6
1.5	Hydro Power	7
1.6	Nuclear Power	8
1.7	Bio-energy	8
1.8	Electricity	9
1.9	Carbon-dioxide emissions	14
1.10	Policy Interventions	15
1.11	Renewable Energy Thrust	16
1.12	Distributed Generation	19
1.13	Smart Cities	21
1.14	Smart Transportation	22
1.15	Smart Grid	24
1.16	Internet of Things (IoT)	26
1.17	Industry 4.0	28
<b>2.</b>	<b>PERFORM ACHIEVE TRADE (PAT) UPDATES</b>	<b>29</b>
2.1	PAT Genesis	29
2.2	Overview of PAT	30
2.3	PAT Concept	31
2.4	Baseline Assessment	31
2.5	Monitoring and Verification	32
2.6	Certification of Energy Savings	36
2.7	Trading of ESCerts	37
2.8	Check Verification	39
2.9	Enforcement of Compliance to PAT	42
2.10	PAT Development	42
<b>3.</b>	<b>KEY THRUST AREAS OF ENERGY CONSERVATION ACT, 2001</b>	<b>49</b>
3.1	Introduction	49
3.2	Standard & Labelling	49
3.2.1	Standard	50
3.2.2	Label	50
3.2.3	Energy Saving Calculation for Submersible Pump Set	53
3.2.4	Star-label Upgradation	54
3.3	Star Rating of Building	54
3.4	Energy Conservation Building Code (ECBC) for Non-Residential (Commercial) Buildings	58
3.4.1	Impact of ECBC Compliance	58
3.4.2	Scope of ECBC (Commercial Buildings)	58
3.4.3	Applicable Building Systems	59
3.4.4	Building Classification	59
3.4.5	Levels of Energy Efficiency Performance	60
3.4.6	Energy Performance	60
3.4.7	ECBC Compliance Approaches & Methods	61

3.4,8	Case Study of an ECBC-compliant Building	63
3.5	Energy Conservation Building Code (ECBC) for Residential Buildings	64
<b>4.</b>	<b>ENERGY EFFICIENCY DATA ANALYTICS</b>	<b>66</b>
4.1	Purpose and Background	66
4.2	Energy Productivity/Efficiency Indicators: Definition and Goal	66
4.3	Energy Efficiency Performance Indicators for Industries	67
4.4	Benchmarking of Sectoral Energy Efficiency	68
4.5	Plant Energy Efficiency Data Analytics	70
4.6	Importance of “Data” in conducting Gap Analysis	75
4.7	Energy Information Management and Analytical Systems (EIMAS)	76
4.8	Centralized Energy Efficiency Data Repository	76
4.9	Policies to Support Industrial Energy Efficiency	77
<b>5.</b>	<b>ENERGY MANAGEMENT SYSTEM (EnMS): ISO 50001: 2018</b>	<b>80</b>
5.1	Introduction	80
5.2	Why ISO 50001 to Manage Energy Effectively?	80
5.2.1	Energy Performance Approach	81
5.2.2	Relationship between Energy Performance and the EnMS	81
5.2.3	Plan-Do-Check-Act (PDCA) cycle	82
5.3	Benefits of Implementing ISO 50001	83
5.4	Why a New ISO 50001 Version?	83
	<b><u>Requirements of ISO 50001:2018 Clauses</u></b> <b><u>(S.No. (1 to 10 below) correspond with clause numbers of the Standard)</u></b>	84
1	<i>Scope</i>	84
2	<i>Normative references</i>	84
3	<i>Terms and definitions</i>	84
4	<i>Context of organization</i>	85
4.1	<i>Understanding the organization and its context</i>	85
4.2	<i>Understanding the needs and expectations of interested parties</i>	85
4.3	<i>Determining the scope of energy management system</i>	86
4.4	<i>Energy management system</i>	87
5	<i>Leadership</i>	87
5.1	<i>Leadership and commitment</i>	87
5.2	<i>Energy Policy</i>	87
5.3	<i>Organizational roles, responsibilities and authorities</i>	88
6	<i>Planning</i>	89
6.1	<i>Actions to address risks and responsibilities</i>	89
6.2	<i>Objectives, energy targets and planning to achieve them</i>	90
6.3	<i>Energy review</i>	91
6.4	<i>Energy Performance Indicators</i>	92
6.5	<i>Energy baseline</i>	93
6.6	<i>Planning for collection of energy data</i>	94
7	<i>Support</i>	95
7.1	<i>Resources</i>	95
7.2	<i>Competence</i>	95
7.3	<i>Awareness</i>	95
7.4	<i>Communication</i>	96
7.5	<i>Documented information</i>	96
7.5.1	<i>General</i>	96
7.5.2.	<i>Creating and Updating</i>	97
7.5.3.	<i>Control of documented information</i>	97
8.	<i>Operation</i>	98
8.1	<i>Operational planning &amp; control</i>	98
8.2	<i>Design</i>	98

8.3	<i>Procurement</i>	99
9.	<i>Performance evaluation</i>	97
9.1	<i>Monitoring, measurement, analysis and evaluation of energy performance and the EnMS</i>	100
9.1.1	<i>General</i>	100
9.1.2	<i>Evaluation of Compliance with legal requirements and other requirements</i>	100
9.2	<i>Internal audit</i>	100
9.3	<i>Management review</i>	101
10.	<i>Improvement</i>	102
10.1	<i>Nonconformity and corrective action</i>	102
10.2	<i>Continual improvement</i>	102
<b>6.</b>	<b>MEASUREMENT AND VERIFICATION OF ENERGY PERFORMANCE OF ORGANIZATIONS</b>	<b>104</b>
6.1	Introduction	104
6.2	Standards, Protocols and Guidelines	104
6.3	Purpose of M&V	105
6.4	M&V Applications	106
6.4.1	Energy Performance Contracts	106
6.4.2	Use of M&V in PAT Scheme	107
6.4.3	M&V for Effective ISO 50001 implementation	107
6.5	Fundamental Principles of M&V	108
6.6	The M&V Process	109
6.7	Factors driving Energy Savings	110
6.8	Measuring Energy Savings and Examples	111
6.9	The Four Basic Options or Methods for Conducting M&V	113
6.9.1	Measurement Boundary	114
6.9.2	Option A Retrofit Isolation: Key Parameter Measurement	114
6.9.3	Option B – Retrofit Isolation: All Parameter Measurement	115
6.9.4	Option C – Whole Facility	116
6.9.5	Option D – Calibrated Simulation	117
6.9.6	Selecting the Option	117
6.10	Uncertainty and M&V Cost	118
6.11	What is not M&V?	119
6.11.1	Difference between “Measurement & Verification” and “Monitoring and Verification”	119
6.11.2	Difference between M&V and Monitoring & Targeting	119
6.12	Conclusion	120
6–i	M&V Plan	121
6–ii	CONTENTS OF A FULL M&V REPORT	123
6–iii	M&V CASE STUDY: EEM: STEAM TRAP REPLACEMENT	124
<b>7.</b>	<b>BEST PRACTICES, TECHNOLOGIES AND CASE STUDIES – ELECTRICAL AND THERMAL SYSTEM</b>	<b>125</b>
7.1	Introduction	125
7.2	Best Practices and Technologies in Electrical System	125
7.2.1	Case for Energy Efficient Motors	125
7.2.2	Variable Frequency Drive (VFD) Applications	128
7.2.3	High COP Chillers	134
7.2.4	Internet of Things (IOT) Application for Chiller System	137
7.3	Best Practices and Technologies in Thermal System	139
7.3.1	Pressure Reducing Turbine	139
7.3.2	Heat Pump	140
7.3.3	Heat Pipe	143
7.3.4	Condensing boiler	144
7.3.5	Absorption chillers	146
7.3.6	Trigeneration	147

7.3.7	Organic Rankine Cycle (ORC)	149
<b>8.</b>	<b>BEST PRACTICES IN BUILDING ENERGY MANAGEMENT AND CONSERVATION</b>	<b>150</b>
8.1	Introduction	150
8.2	Green Building	151
8.3	Net Zero Energy Building (NZEB)	154
8.4	Building as an Energy System	154
8.5	Energy Saving Approaches for Building	155
8.5.1	Passive Designs	155
8.5.2	HVAC	163
8.5.3	Lighting	168
8.5.4	Renewable Energy	170
8.5.5	Other areas	170
8.5.6	Emerging Trends	172
<b>9.</b>	<b>RENEWABLE ENERGY TECHNOLOGIES AND APPLICATIONS</b>	<b>174</b>
9.1	Introduction	174
9.2	Types of Renewable Energy System	174
9.3	Installable Potential and Installed Capacities	175
9.4	Solar Energy	175
9.4.1.	Solar Radiation Resource	176
9.4.2	Solar Thermal Applications	177
9.4.3	Flat Plate Collectors (FPC) based Solar Water Heaters	177
9.4.4	Evacuated Tube Collectors (ETC) based Solar Water Heaters	178
9.4.5	Concentrated Solar Power (CSP)	178
9.4.6	Parabolic Solar Dish Collector	179
9.4.7	Parabolic Trough Collectors (PTC)	179
9.4.8	Linear Fresnel Collectors	180
9.4.9	Power Towers	180
9.4.10	Industrial Applications of Solar Thermal Energy	181
9.4.11	Solar PV Technology	182
9.4.12	PV system types	184
9.4.13	Grid-connected (Rooftop Solar) PV Plant	184
9.4.14	Approach and Methodology to Develop a Rooftop PV Plant	186
9.4.15	Off Grid Solar PV	188
9.4.16	Business Models for Installation of Large Capacity Rooftop	189
9.4.17	Solar Power Parks	190
9.4.18	New Solar Technologies	191
9.5	Wind Energy	192
9.5.1	Types of Wind Turbines	192
9.5.2	Development of Wind Project	193
9.5.3	Offshore Wind Energy	194
9.5.4	Repowering	194
9.5.6	Small-scale Wind turbine	194
9.5.7	Small Wind–Solar Hybrid System	195
9.6	Bio-energy	196
9.6.1	Direct Combustion of Biomass	196
9.6.2	Co-firing of Biomass	197
9.6.3	Biomass Gasification	197
9.6.4	Anaerobic Digestion	198
9.6.5	Liquid Biofuels	199
9.7	Small-scale Hydropower	200
9.8	Electrical Energy Storage (EES)	201
9.9	RE/EE Integration for mitigation of Climatic Change	204



<b>10.</b>	<b>GHG AND CARBON FOOTPRINT ACCOUNTING AND REPORTING</b>	<b>208</b>
10.1	Introduction to Greenhouse gases and Carbon Foot Print	206
10.2	Global Greenhouse Gas Emission Scenarios	208
10.3	Indian GHG Scenario	209
10.4	GHG Accounting and Reporting	210
10.5	Relevant Protocols and Standards	210
10.6	Estimating GHG or Carbon Emissions	211
10.7	Calculations and Methods for Determining GHG Emissions	212
10.7.1	Measuring GHG emissions from identified sources converting them to CO2 equivalent using GWP	212
10.7.2	Measuring energy use and converting it to CO2 equivalent using notified emission factors	212
10.7.3	Estimating emissions from production using product emission factors	213
10.7.4	Estimating emissions based on fuel consumed and its composition (ultimate analysis)	214
10.7.5	Approaches for estimating GHG emissions from transport	214
10.7.6	Estimating GHG emissions from chemical reaction using material balance approach	215
10.8	Carbon Footprints	215
10.9	Types of Carbon Footprints	216
10.9.1	Organizational Footprint	216
10.9.2	How to calculate an Organizational Footprint?	219
10.9.3	Communicating organizational carbon footprint	221
10.10	Reporting GHG Emissions	221
	<b>A. ENERGY AUDIT INSTRUMENTS</b>	<b>223</b>
A1.	Introduction	223
A2.	Typical Instruments Used For Energy Audit	223
	<b>B. SOFTWARE AND SIMULATION FOR ENERGY AUDITING</b>	<b>229</b>
B1	Introduction	229
B2	Applications of Various Softwares	229
B3	Softwares for Process Plants, Power Plants, Solar Systems Refinery, Optimizing Heat Exchanger network, Steam plants, and other thermal systems	233
	<b>REFERENCES</b>	<b>242</b>

## LIST OF TABLES

		<b>Page no.</b>
1.1	Breakup of Installed Capacity by Energy Source	10
1.2	Electricity Generation by Fuel Source	10
1.3	Renewable energy installed capacity in India (MNRE)	12
1.4	Per Capita Electricity Consumption (CEA)	13
2.1	Timelines and Activities for a PAT Cycle	35
2.2	PAT Cycle-I (2012-13 to 2014-15)	43
2.3	Details of DCs in PAT-II (2016-2019)	44
2.4	SEC Norms for Electric /Diesel Traction of Zonal Railways	45
2.5	Targets for PAT-III (2017-2019)	47
2.6	No. of DCs Covered in PAT Cycles II, III, and IV	47
3.1	Verified Building Information and Energy Data for the BPO	56
3.2	Bandwidths for BPO Buildings for 4 Climatic Zones	57

4.1	Energy Efficiency Performance Indicators <sup>1</sup> for Indian Industry	67
4.2	Specific Energy Consumption in Industry – India and the World	69
4.3	Energy Efficiency Policy & Program Pathway in Indian Industry Sector	78
5.1	Consistency Relationship between Policy, Objective, Target and Action Plan	91
5.2	Sample Training Plan	96
6.1	Four Basic Options or Methods for Evaluating Avoided Energy Use	114
7.1	IE Classes	126
7.2	Typical Compressor Sizes and Efficiencies	136
7.3	Typical Chiller Types and Efficiencies	147
8.1	List of Green Building Features	152
8.2	Energy Saving Potential in HVAC System Design	163
9.1	Installable Potential and Installed Capacities	175
9.2	Typical SHWS Capacity and Collector Area	177
10.1	GHG and its GWP	211
10.2	Estimation of Total GHG Emissions based on emission releases	212
10.3	GHG Emissions Factors	213
10.4	Estimation of Total GHG Emissions based on Fuel/ Power Consumption	213
10.5	Estimation of Total GHG Emissions based from emission factors	214
10.6	Ultimate Analysis of Sub-Bituminous coal	214
10.7	Activities Covered Under Each Scope	218
A1	Introduction	223
A2	Typical Instruments Used For Energy Audit	223

## LIST OF FIGURES

		Page no.
1.1	Break-up Primary Energy Consumption by Fuel/Source	1
1.2	Breakup of World Primary Energy Consumption by Fuel/Source	1
1.3	World Primary Energy Consumption Trend	2
1.4	Primary Energy Consumption Trend of India	2
1.5	Coal Reserves by Country (Total Reserves 1035 Billion Tonnes in 2017)	3
1.6	India's Coal Energy Scenario	3
1.7	Coal Demand by Sector: 2015-16 (Quantity in Million Tonnes)	4
1.8	India's Oil Energy Scenario	5
1.9	Sector-wise Breakup of Petroleum products Consumption 2016-17	5
1.10	India's Gas Energy Scenario	6
1.11	Gas Demand by Sector FY 2015-16	7
1.12	Electricity Installed Capacity by Energy Source	9
1.13	Electricity Generation by Fuel Source	10
1.14	Electricity Consumption by Sectors in India during 2016-17	11
1.15	Final Commercial Energy Consumption (MTOE) By Various Sectors 2015-16	11
1.16	Renewable Energy Installed Capacity in India (%) (MNRE)	12
1.17	Energy Intensity Trend	14

1.18	CO <sub>2</sub> Emissions Trend	14
1.19	Break-up of Targeted Generation of 175 GW (MNRE)	16
1.20	Road Map for Solar Power by 2022 (MNRE)	16
1.21	Distributed Generation	20
1.22	Conventional Grid	24
1.23	Schematic Representation of Smart Grid	26
2.1	Components of NMEEE	29
2.2	Concept of Target, Compliance, ESCerts and Penalty	30
2.3	PAT Concept	31
2.4	SEC Assessment Using Gate-to-Gate Approach	32
2.5	Reductions in SEC	32
2.6	Process Flow for ESCerts Trading	38
2.7	Process of Check Verification	48
2.8	GtG for Building	
3.1	Endorsement Label (Laptops)	50
3.2	Examples of Comparative Labels	51
3.3	Label Information for a Refrigerator	52
3.4	Example of Star level Upgradation under Star Labelling program of Variable Speed Room Air Conditioners	54
3.5	ECBC-Compliance Approach	61
4.1	Energy Productivity Indicators	67
4.2	Pyramid of Energy Indicators in Industry	68
4.3	Data Sources for GAP analysis	71
4.4	GAP Analysis Steps	71
4.5	SECs Compared with SEC(BAT)	72
4.6	Prioritization through GAP analysis	72
4.7	Steps for Target Setting	73
4.8	Realistic Target Setting	73
4.9	Normalization Factors for Adjusting SEC Targets	74
4.10	Variation of SEC for Alumina Refinery Units	75
4.11	Importance of Normalizing data before Gap Analysis <sup>1</sup>	75
4.12	EIMAS and CEEDR Linkinge	77
4.13	Industrial Energy Productivity Policy Planning and Implementation Process	79
5.1	Relationship between EnMS and Energy Performance	81
5.2	PDCA cycle	82
5.3	Addressing Legal and Other Requirements	86
5.4	Model Energy Policy	88
5.5	Strategic Planning to address risk and responsibilities	89
5.6	Energy Review	89
5.7	Energy Performance Indicator	93
5.8	EnMS journey Review	103
6.1	Steps involved in M&V Process	110
6.2	Energy Savings Depend upon Performance and Usage	110
6.3	Energy Use of Industrial Boiler before and after ECM	111
6.4	Illustrations of M&V Options	113
6.5	Balancing Uncertainty and M&V Costs	119
7.1	Efficiency classes IE1 to IE4	128
7.2	Variable Torque Load	128
7.3	Constant torque Load	129
7.4	Constant Power Control	129
7.5	Damper versus VFD	129

7.6	Load/Unload Control	133
7.7	VFD Control	130
7.8	(a) Multiple datasets from Sensor Networks	137
	(b) Optimization Approach from sensor networks Real Time Machine Learning Model	137
7.9	Compressor Power consumption– IOT vs Non-IOT	138
7.10	IOT for Chillier System Efficiency	138
7.11	Pressure Reducing Turbine Application	139
7.12	Schematic Diagram of Heat Pump	140
7.13	Heat Pump Circuit	142
7.14	Schematic Diagram of Heat Pipe	143
7.15	Schematic diagram of the Condensing Boiler	145
7.16	Overall Thermal Efficiency Vs Temperature of Flue Gas	146
7.17	Trigeneration	147
7.18	Trigeneration Application	148
7.19	ORC Process Schematic	149
8.1	Energy Consumption in an Information Technology Park Building	150
8.2	NZEB Concept	154
8.3	Sustainable Cooling Strategy	155
8.4	Cool Roofs	156
8.5	Green Roofs	156
8.6	Types of Shading	157
8.7	Fenestration	157
8.8	Properties relevant to Daylight Harvesting	158
8.9	DGU with Low-E-Coating	159
8.10	Heat Loss Comparison	159
8.11	Effective Schemes for Natural Ventilation	160
8.12	Stack Effect Ventilation	161
8.13	Passive Downdraft Evaporative Cooling	161
8.14	Dome Shaped Skylights	162
8.15	Internal Light Shelf	162
8.16	Chilled Water System	164
8.17	Ice-Bank System	164
8.18	Schematic diagram of a Trigeneration system	165
8.19	Schematic Diagram of a Radiant Cooling System	166
8.20	Demand Controlled Ventilation	167
8.21	Schematic diagram of a Solar Air Conditioning System	168
9.1	Various Forms of Renewable Energy Resources	174
9.2	Global Irradiation	176
9.3	Flat Plate Collector	177
9.4	Evacuated Tube Collector	178
9.5	Solar Dish Collector	179
9.6	Parabolic Trough Collector	179
9.7	Schematic of a PTPP with a Thermal Storage System	180
9.8	Power Tower	181
9.9	Solar Thermal Heat for Pre-heating of Feed to Steam Boiler	182
9.10	PV Modules	183
9.11	Inverter	183
9.12	Grid-Connected (Utility-Interactive) PV System	185
9.13	Net-metering	186
9.14	Typical Stand-alone PV System Powering DC and AC Loads	188
9.15	CAPEX Model	189
9.16	RESCO Model	190
9.17	Horizontal Axis Wind Turbine	193
9.18	Vertical Axis Wind Turbine	193
9.19	Offshore Wind Turbine	194

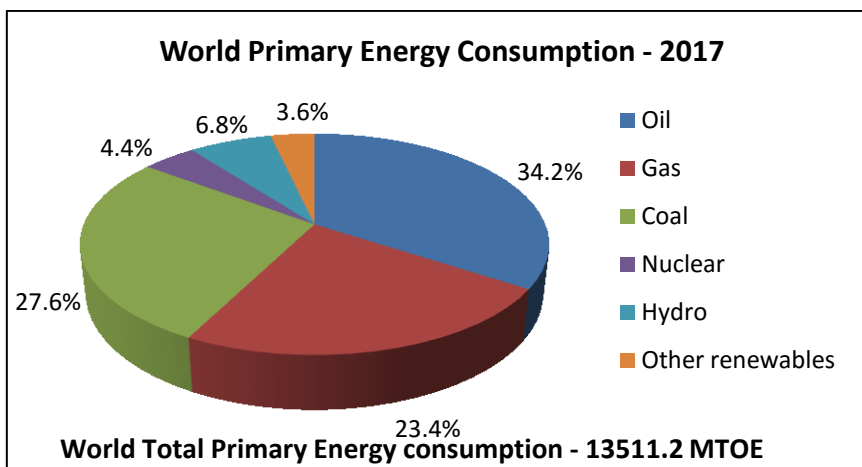
9.20	Hybrid Wind-Solar Power System	196
9.21	Downdraft Gasifier	197
9.22	Anaerobic Digestion	198
9.23	Run-of River Hydro	200
9.24	Electrical Energy Storage (EES)	202
10.1	Global CO <sub>2</sub> Concentration Increase Since 1980	206
10.2	Global Average Annual Temperature Trend	207
10.3	Potential Future GHG Emission Pathways	209
10.4	The Different Boundaries of Organisational and Product Footprints	217
10.5	The Different Scopes of Carbon Emissions	219
B1	Pump Efficiency Calculations	230
B2	Model of Pumping System	231
B3	Results of Pump versus System Curve	231
B4	Data Input	238
B5	Data Inputs (Multiple Compressors)	239
B6	Output Screen (Single Compressor Simulation)	240



## 1.0 ENERGY SCENARIO UPDATES

### 1.1 Introduction

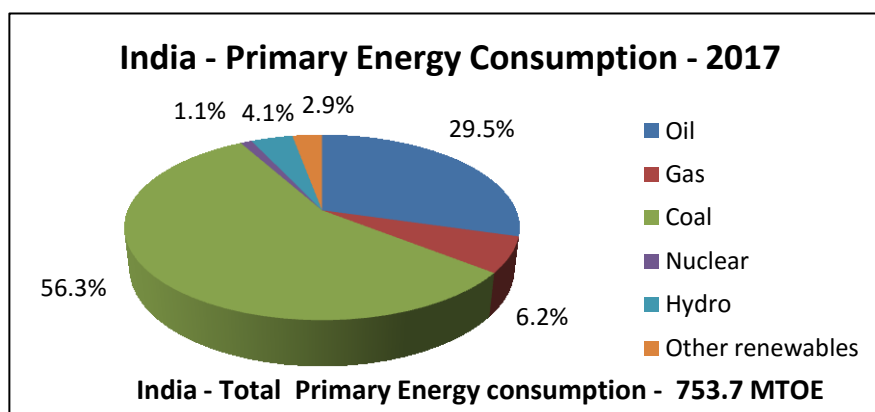
Fossil fuels such as oil, natural gas, and coal have been the world's primary energy source for several decades. Currently, conventional fossil fuels supply about 85% of the global primary energy consumption for industrial, transportation, commercial and residential uses. Total primary energy consumption comprising commercially-traded fuels including renewable energy was 13511.2 million tonnes oil equivalent (MTOE) in 2017. The world primary energy consumption by fuel type/source is shown in Figure 1.1.



**Figure 1.1: Breakup of World Primary Energy Consumption by Fuel/Source**

Source: BP Statistical Review of World Energy 2018

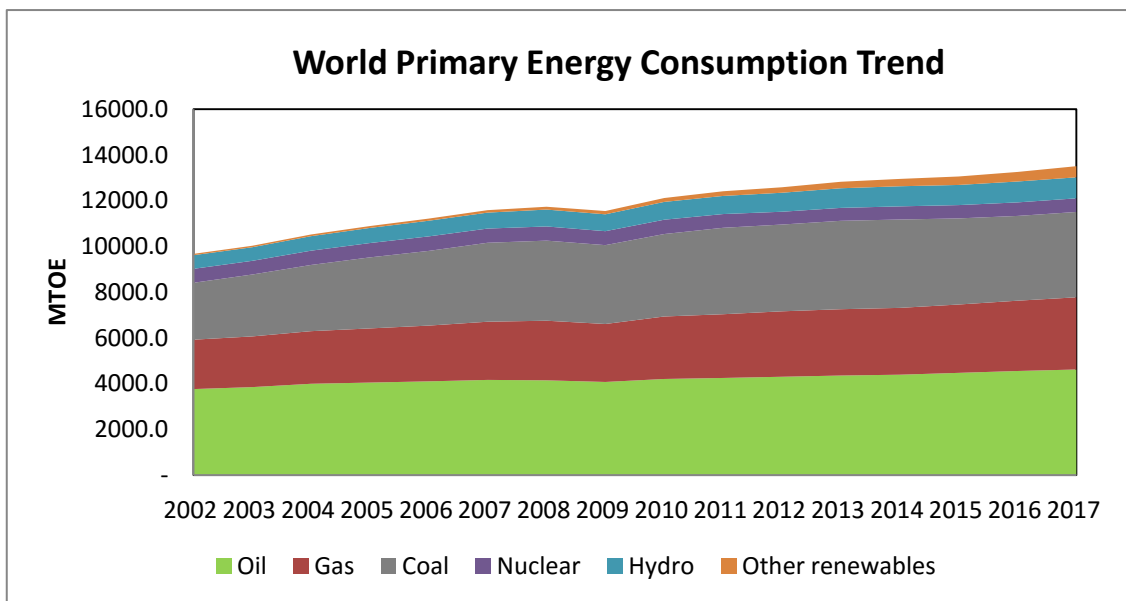
India's primary energy consumption was 753.7 million tonnes oil equivalent in 2017, which is about 5.6% of the world's consumption and third highest after China and the United States. Its energy consumption is projected to grow by 4.2% annually, faster than all major economies in the world. Indian economy faces significant challenges in meeting energy needs in the coming decades. The increasing energy needs coupled with slower than expected increase in domestic energy production has meant that bulk of energy will have to be met by imports. The consumption by energy source/type is shown in the Figure 1.2.



**Figure 1.2: Breakup of India's Primary Energy Consumption by Fuel/Source**

Source: BP Statistical Review of World Energy 2018

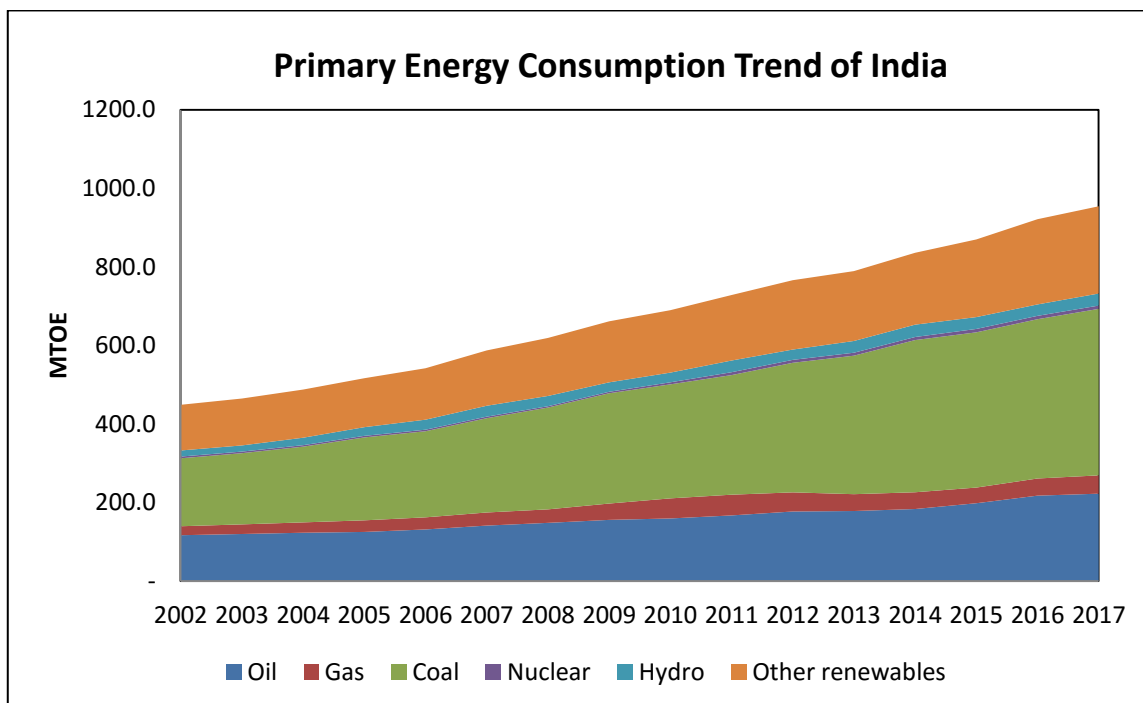
The world is facing the reality that fossil fuels will be exhausted soon as the global consumption rate is outpacing the discovery and exploitation of new reserves, and that the global environment is worsening due to increasing greenhouse gas (GHG) emissions caused by fossil fuels. The world primary energy consumption trend is shown in Figure 1.3.



**Figure 1.3: World Primary Energy Consumption Trend**

Source: BP Statistical Review of World Energy 2018

The India's growth of primary energy consumption is shown in Figure 1.4.



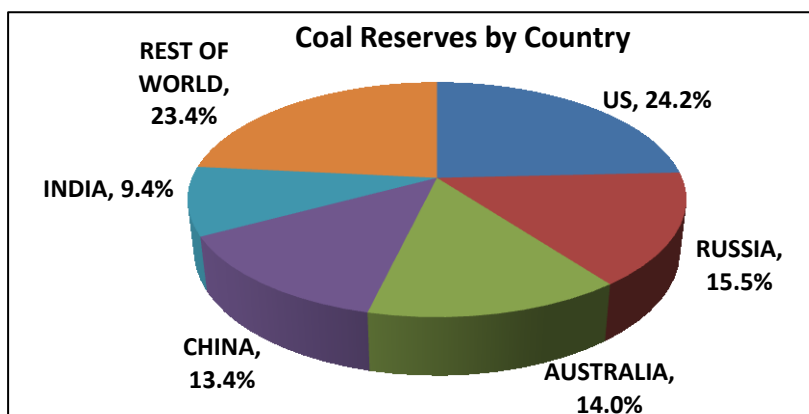
**Figure 1.4: Primary Energy Consumption Trend of India**

Source: BP Statistical Review of World Energy 2018



## 1.2 Coal

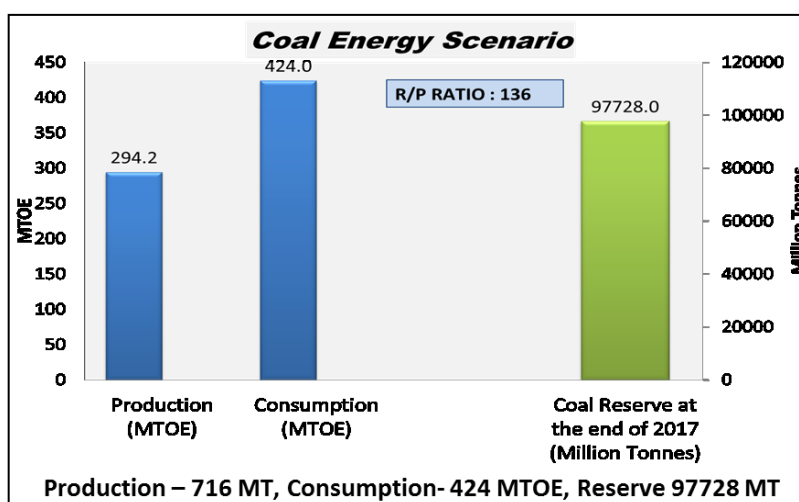
Coal is the predominant of the three major fossil fuels and most widely distributed with reserves in over 100 countries. The coal reserves by country are shown in Figure 1.5. World proved coal reserves are currently sufficient to meet 136 years of global



**Figure 1.5: Coal Reserves by Country (Total Reserves 1035 Billion Tonnes in 2017)** (Source: BP Statistical Review of World Energy)

production, which means that Reserve/Production (R/P) ratio is much higher than that of oil and gas.

India has 9.4% of the world reserves (fifth largest coal reserves in the world after the US, Russia, China, and Australia.) with an estimated R/P ratio of 136 years. India is second largest in terms of coal consumption after China. India's coal scenario is presented in Figure 1.6. The share of coal (including lignite) in the primary energy mix of the country is the highest at 56 %. Coal used in India comprises 10% coking coal and 90% non-coking coal.



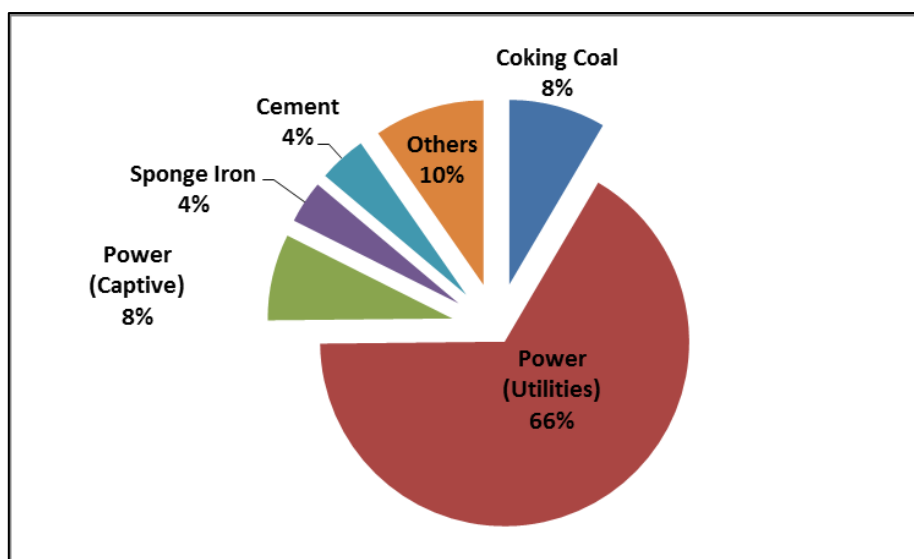
**Figure 1.6: India's Coal Energy Scenario**

(Source: BP Statistical Review of World Energy)

Coal is mainly used as a fuel for electricity generation and other industrial processes such as iron and steel, and cement manufacturing. Domestic coal production has been inadequate to meet the total demand of coal in the country. Large quantities of coal are being imported from other countries to meet the shortfall in domestic coal production, and compensate for low calorific value and high ash content in domestic coal. Coal demand by sector is given in Figure 1.7.

Although use of coal is not compatible with GHG reduction, it will continue to be the dominant fuel as about 76.2% by electricity generation (utility and captive) in India is coal-based (Source: BP Statistical Review of World Energy).

Coal also plays an important role in the security of supply and will continue to supply a strategic share over the next three decades. The efficiencies of most of coal-fired power plants in India range from 28 to 32% as compared to 45% for the most efficient plant (IEA).



**Figure 1.7: Coal Demand by Sector: 2015-16 (Quantity in Million Tonnes)**

Source: Sector-wise Demand as per Annual Plan of Min. of Coal, GOI.

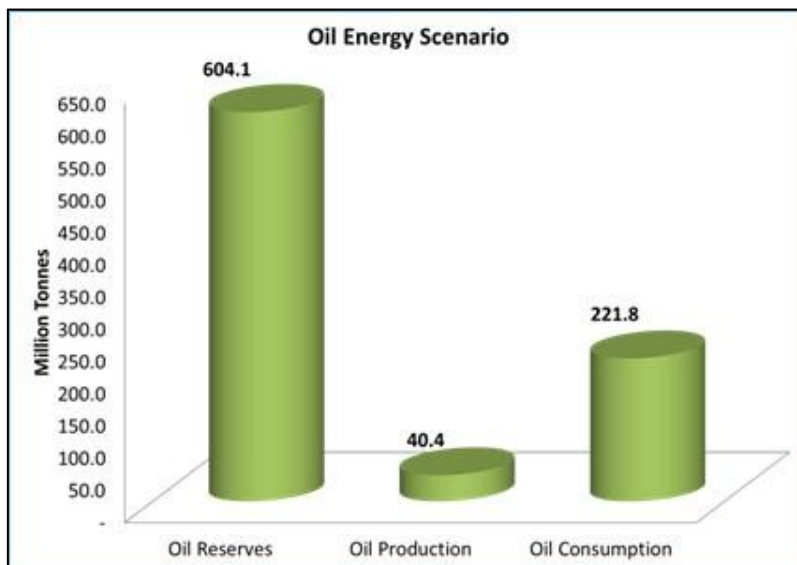
Efforts for use of clean coal include beneficiation of coal for improving coal quality. Coal washing is one of the prevalent techniques adopted under beneficiation. The washing process consists of removing impurities (mainly ash, sulphur and rocks) from the raw coal. Ministry of Environment, Forest and Climatic Change (MoEFCC) issued a directive in 2016 which requires washing of coal for supplies to stand-alone power plants of any capacity or a captive power plant of 100 MW or above located within 500 and 749 km from pitheads.

The various other efforts being proposed by government and industry in the coming decades include repowering existing coal-fired plants to improve their efficiency, replacing inefficient subcritical power plants with energy efficient and low carbon technologies such as super critical and ultra-super critical plants equipped with carbon capture technologies, which would emit almost 40% less CO<sub>2</sub> than subcritical plants.

### 1.3 Oil

Oil remains the world's leading energy source, accounting for about 34% of total global energy consumption in 2017. In recent years, supply of unconventional oil (shale oil, oil sands, natural gas liquid, liquid fuels derived from coal and gas) along with increased crude production both from mature oil fields has supported oil demand. Major demand for oil has come from transportation sector.

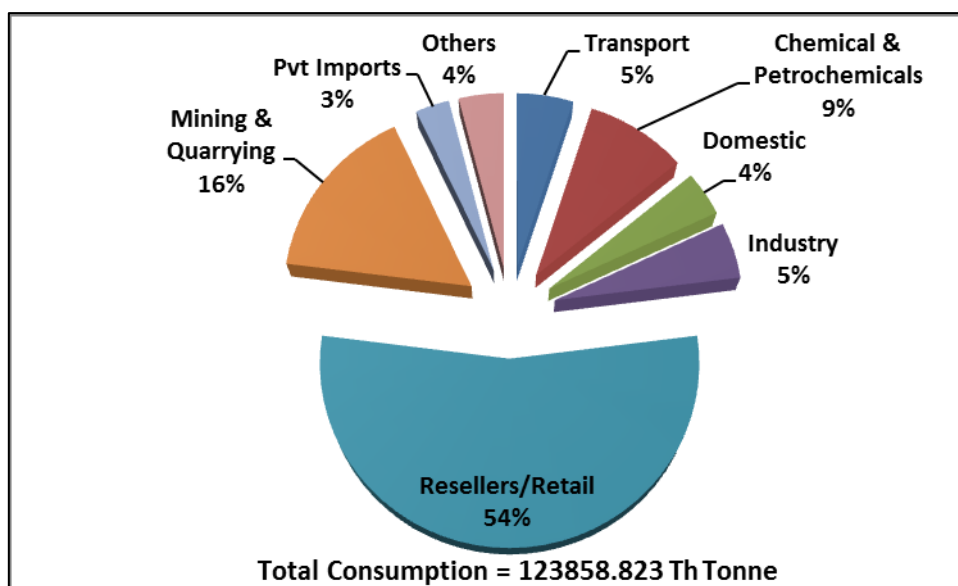
India has only 0.3% of the world reserves with an estimated R/P ratio of only 14.4 years while its share of world consumption is 4.8% (2007). India imports over 80% of its crude oil requirements amounting to 211.1 million tonnes (4239 thousand barrels daily) in 2017. India's oil scenario is presented in Figure 1.8.



**Figure 1.8: India's Oil Energy Scenario**

(Source: BP Statistical Review of World Energy)

The growing mobility and increasing demands for passenger and freight movement has increased the consumption of petroleum products in the road transport sector. Transport sector is the largest consumer of commercial energy (diesel and petrol). There is a continual shift in the share of railways in freight movement to less fuel-efficient road transport mode. The road-based mobility is the dominant mode in passenger transport as well. Sector-wise petroleum product consumption (%) is shown in Figure 1.9.



**Figure 1.9: Sector-wise Breakup of Petroleum products Consumption 2016-17**

Source: Energy Statics 2018, CENTRAL STATISTICS OFFICE

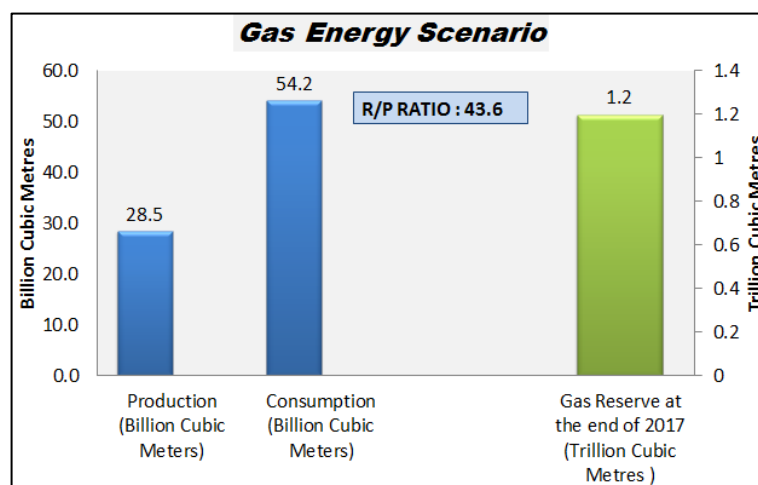
Government is continually promoting improvements in energy efficiency in conventional vehicles. India has adopted Euro 6/VI equivalent standards that will go into effect in 2020. The passenger car fuel efficiency standards has been finalized that would result in an

average fuel consumption of 20 km/L for the four-wheeled passenger vehicles. However, it is to be noted that heavy duty vehicles (HDV) dominate the overall fuel consumption in the road transport sector is untouched.

The government is also promoting growth in fully electric and hybrid vehicles in the coming years. Government of India has also proposed methanol and ethanol blending in petrol. Ethanol Blending Programme aims at 20 percent ethanol blending in petrol by 2030, but faces supply constraints.

## 1.4 Natural Gas

It is the number three fuel, contributing 23.4% of global primary energy. Unconventional gas, shale and coal bed methane (CBM) are also available as LNG in the regional gas markets. Natural gas is the only fossil fuel whose share of the primary energy mix has seen the highest growth rate internationally and has the potential to play an important role in the transition to a cleaner, more affordable and secure energy future. Natural Gas offers a much cleaner alternative to coal for power generation and produces only around half of the carbon dioxide (CO<sub>2</sub>) emissions of coal when burned to generate power.



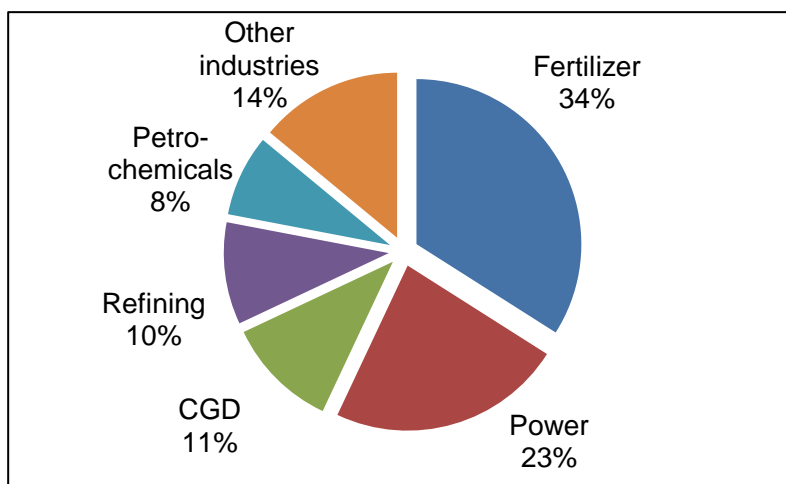
**Figure 1.10: India's Gas Energy Scenario**

(Source: BP Statistical Review of World Energy)

India has only 0.6% of the world reserves with an estimated R/P ratio of 43.6 years (Figure: 1.10) while its share of world consumption is 1.5%. About 40% of the consumption is met by imports. The Government wants to make India a gas-based economy by boosting domestic production and buying cheap LNG. India has set a target to raise the share of gas in its primary energy mix up to 15% by 2022.

Natural gas is becoming more accessible in India thanks to a growing global gas market. Natural gas is available as (i) Domestic Natural Gas and (ii) Imported Re-gasified Liquefied Natural Gas (R-LNG). Since conceptualizing National Gas Grid (NGG) in 2000, India has built extensive gas pipeline network, R-LNG terminals and City Gas Distribution (CGD) networks. However, the pipeline network has been developed mostly in the northern and western regions. A large part of the country lacks transmission infrastructure and access to gas.

Gas consumption is dominated by sectors such as fertilizer, power, refineries, city gas distribution and petrochemicals (Figure 1.11). The gap between production and demand is met LNG imports. The government gas allocation policy give priority of gas supply to heavily subsidized fertilizer industry and city gas distribution.



**Figure 1.11: Gas Demand by Sector FY 2015-16**  
**Source: MoPNG**

CGD sector has four distinct segments—Compressed

Natural Gas (CNG) mostly used as auto-fuel, and Piped Natural Gas (PNG) used in domestic, commercial and Industrial applications.

CNG is now prevalent in around 11 Indian states, with many cities mandating its use in public transport (taxis, auto-rickshaws and buses). The growth in this sector is severely constrained by insufficient number of CNG filling stations.

With proposed creation of smart cities, natural gas transmission infrastructure is being expanded. India is currently expanding piped natural gas to cover 10 million households within the next four years.

In 2013, Government instituted the Direct Benefit Transfer for LPG scheme to administer domestic LPG subsidy linked to Aadhar (Unique Identification card).

The Pradhan Mantri Ujjwala Yojana, a new scheme launched on 1 May 2016 to provide free LPG connections to women from below poverty line families has surpassed the target of 1.5 crore connections for 2016/7 by providing 2.2 crore new LPG connections.

Government has also launched “Give it up” campaign to encourage well-to-do households to voluntarily give up their subsidy so that the saved amount could be utilized to provide LPG connections to poor households who depend on polluting cooking fuels. This campaign is also aimed at reducing subsidy burden of LPG.

## 1.5 Hydro Power

Hydropower is the leading renewable source for electricity generation globally, supplying 71% of all renewable electricity. Hydro projects are not only considered as a means of power generation but also as water security to the country. Hydropower has good synergies with all generation technologies, for example, pumped hydro can be used as storage, as well as to balance the power variability caused by increased renewable energy fed into the grid.

India has the potential of about 150 GW hydro power and out of which about 43 GW (up to 31.03.16) has been installed and operating at a load factor of 60% or lower. Renovation, modernisation and up-rating of old hydro power plants is being periodically carried out to overcome power shortage and resource constraints. Older hydro power units (>30 years) are being refurbished to enhance the installed capacity to extend its useful life by further 15–20 years. Nearly 94,000 MW is estimated to be available from pumped hydro schemes, across 56 sites.

India has an estimated potential of 25 GW of small hydro projects (up to 25 MW capacity as defined by MNRE). As of 2017 about 4.4 GW of small hydro projects (less than 10 MW) have been installed.

## **1.6 Nuclear Power**

The development of nuclear power is today concentrated in a relatively small group of countries namely China, Korea, India and Russia. As of January 2015, the total identified resources of uranium are considered sufficient for over 100 years' of supply based on current requirements.

The nuclear is increasingly seen as a means to add large scale base load power generation while limiting the amount of GHG emissions. The low share of fuel cost in total generating costs makes nuclear the lowest-cost base load electricity supply option. Uranium costs account for only about 5% of total generating costs and thus protect plant operators against fuel price volatility.

India has 22 nuclear reactors in operation in seven nuclear power plants, having a total installed capacity of 6780 MW or nearly 2% of total installed utility power generation capacity. Nuclear plants generated 38,247 million kWh at 64.4% PLF in the year 2017-18. Pressurized Heavy Water Reactors (PHWR) based on natural uranium account for almost all of the present installed capacity. Six more reactors are under construction with a combined generation capacity of 4300 MW.

## **1.7 Bio-energy**

Bio-energy is energy from organic matter (biomass) i.e. materials of biological origin that is not fossilised. It represents the transformation of organic matter into a source of energy, whether it is collected from natural surroundings or specifically grown for the purpose; for example, agricultural residues and social forestry. It can be used in its original form as fuel, or be refined to different kinds of solid, gaseous or liquid biofuels.

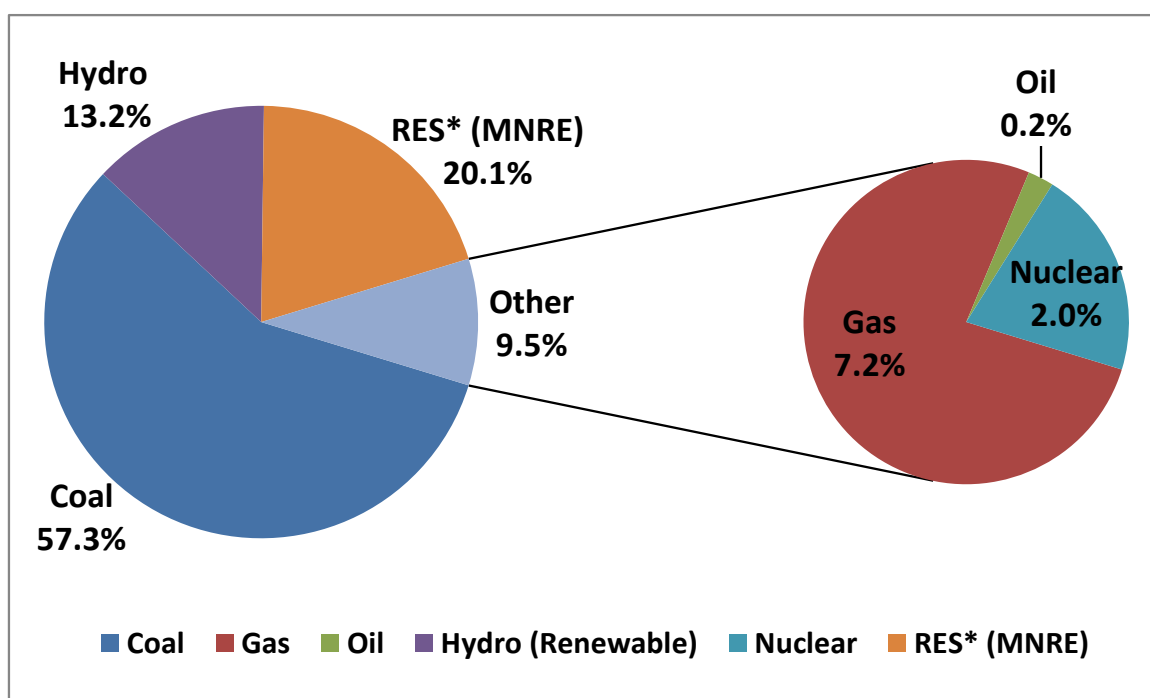
---

Bioenergy supplies 10% of global energy supply. Traditionally, biomass is seen as the main domestic fuel, especially in more rural areas without access to electricity or other energy sources. Bioenergy is gradually shifting from a traditional and indigenous energy source to a modern and globally traded commodity. Climate change and energy independency are major drivers for bioenergy development. These fuels can be used in all sectors of society, for production of electricity, for transport, for heating and cooling, and for industrial processes. Bioethanol is being promoted as an alternative sustainable source to hydrocarbon-based fuels (petrol/diesel) used in transportation.

Around 500 million tonnes per annum (MTPA) of biomass is available in India. Approximately, 120-150 MTPA of biomass (covering agricultural and forest residues) is estimated to be surplus, which corresponds to a potential of approximately 18000 MW of electricity. Apart from this 5000 MW and 2600 MW of additional power can be generated through bagasse-based cogeneration and waste-to-energy plants, respectively.

## 1.8 Electricity

India is the world's third largest producer and consumer of electricity with installed capacity of 344 GW as on 31 May 2018. The break-up of installed capacity by energy source is shown in Figure 1.12 and Table 1.1.



**Figure 1.12: Electricity Installed Capacity by Energy Source**

\* Installed capacity in respect of RES (MNRE) as on 31.03.2018. RES (Renewable Energy Sources) include Small Hydro Project, Biomass Gasifier, Biomass Power, Urban & Industrial Waste Power, Solar and Wind Energy

**Table 1.1: Break-up of installed capacity by Energy Source**

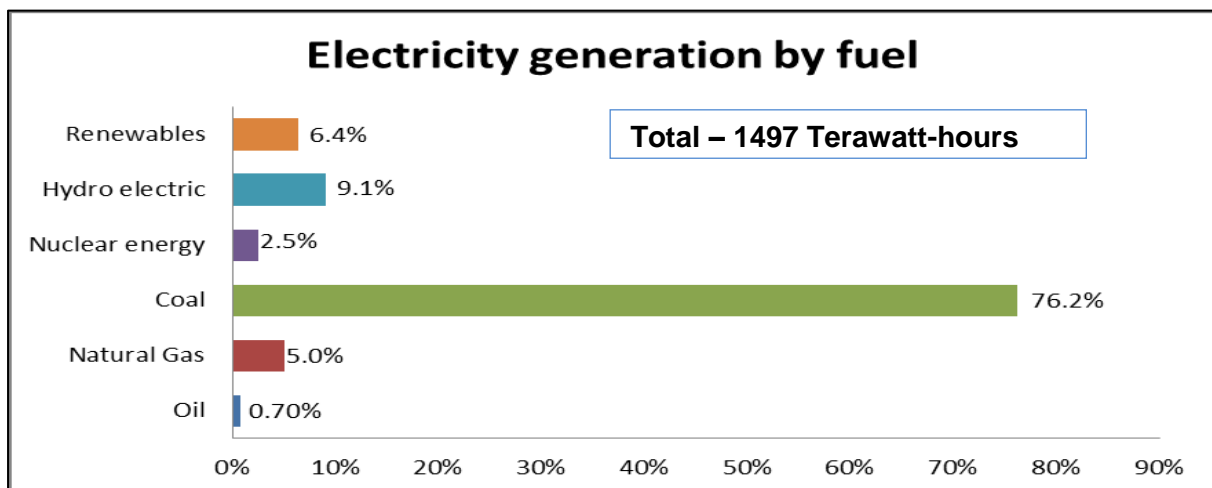
Fuel	MW	% of Total
<b>Total Thermal</b>	2,22,693	64.80%
<b>Coal</b>	1,96,958	57.30%
<b>Gas</b>	24,897	7.20%
<b>Oil</b>	838	0.20%
<b>Hydro (Renewable)</b>	45,403	13.20%
<b>Nuclear</b>	6,780	2.00%
<b>RES* (MNRE)</b>	69,022	20.10%
<b>Total</b>	<b>343,899</b>	

Electricity generation by fuel source is shown in Table 1.2 and Figure 1.13. India's electricity sector is dominated by coal-based power plant for meeting about 76.2% of all electricity needs.

**Table 1.2: Power Generation by Fuel Source**

Energy source	Oil	Natural Gas	Coal	Nuclear energy	Hydro electric	Renewables	Others	Total
<b>Terawatt-hours</b>	10.3	75.5	1141.4	37.4	135.6	96.4	0.3	1497
<b>%</b>	0.7	5	76.2	2.5	9.1	6.4	0.02	100

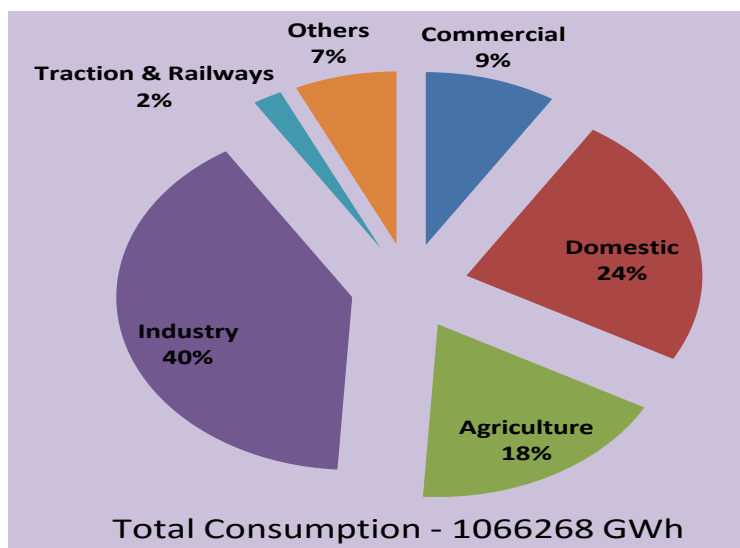
Source: BP Statistical Review of World Energy

**Figure 1.13: Electricity Generation by Fuel Source**

The overall plant load factor (PLF) of all thermal power plants (central, state and private) is only about 65%. The Government is undertaking Renovation & Modernization and Life Extension of old existing power plants to effectively utilize existing capacity and improve PLF.

Industry dominates electricity consumption (40%) followed by domestic (24%) and agriculture (18%) as shown in Table 1.14.

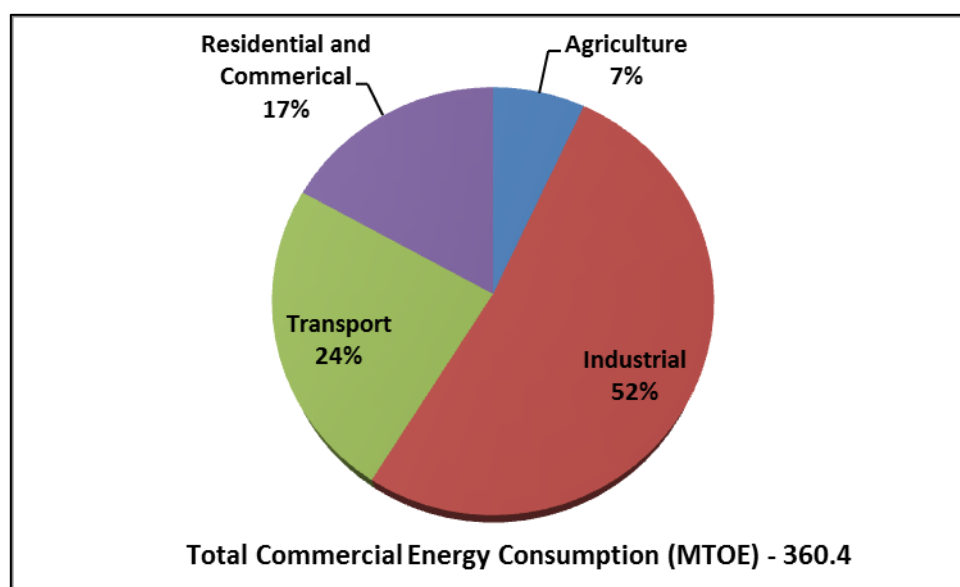




**Figure 1.14: Electricity Consumption by Sectors in India during 2016-17**

(Source: Energy Statics 2018, CENTRAL STATISTICS OFFICE)

Final commercial energy consumption is dominated by industrial sector (52%), followed by transport (24%), and by residential and commercial (17%) sectors (Figure 1.15).



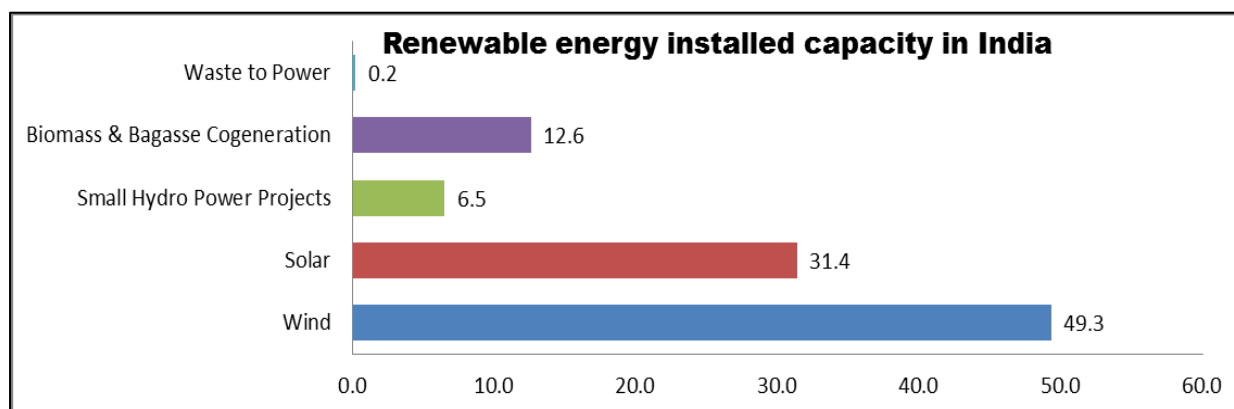
**Figure 1.15: Final Commercial Energy Consumption (MTOE) By Various Sectors 2015-16**

(Source: TERI Energy & Environment Data Dairy and Yearbook 2016/17)

Renewables are the fastest-growing energy source in the world today. It is expected to meet at least 14% of the global energy mix by 2040. India is very active in renewable energy development, especially solar and wind electricity generation. India had grid connected installed capacity of about 69.02 GW renewable technologies as of 31 March 2018. The plan is to achieve a total of 175 GW total installed capacity by 31 March 2022. The break-up of installed capacity by type of (grid-connected) renewable is shown in Table 1.3 and breakup of renewable energy installed capacity (%) is shown in Figure 1.16.

**Table 1.3: Renewable Energy Installed Capacity in India (MNRE)**

Type	Capacity (in MW)
<b>Grid Connected Power</b>	
Wind	34,046.00
Solar	21,651.48
Small Hydro Power Projects	4,485.81
Biomass Power & Gasification and Bagasse Cogeneration	8,700.80
Waste to Power	138.30
<b>Total - Grid Connected Power ( as of 31 March 2018)</b>	<b>69,022.39</b>

**Figure 1.16: Renewable Energy Installed Capacity in India (%) (MNRE)**

The effective implementation of Electricity Act 2003 contributed to remarkable achievements during last ten years.

**Electricity Act 2003:** The objective of the act is to introduce competition, protect consumer's interests and provide power for all. The Act provides for National Electricity Policy, Rural Electrification, Open access in transmission, phased open access in distribution, mandatory SERCs, license free generation and distribution, power trading, mandatory metering and stringent penalties for theft of electricity.

The various policy interventions proposed in power sector include the following:

- A strong push for renewable energy (mainly solar and wind power), with a target to achieve 175 GW of installed capacity.
- Enhanced efforts on village electrification and connection of households lacking electricity supply with the goal to reach universal electricity supply.
- Move towards mandatory use of supercritical technology in new coal-fired power generation.
- Expanded efforts to strengthen the national grid and reduce T&D losses (target: 15 %.)

## Policy Indicators

Per-capita electricity consumption and energy intensity are the most used policy indicators, both at national and international levels.

### Per-capita Electricity Consumption

All India per-capita electrical consumption has increased from 631.4 kWh (2005-2006) to 1075 (2015-16). All India Annual per Capita Consumption of Electricity since 2006 is shown in the Table 1.4. The government is pursuing a Rs.16,320 crore project called Saubhagya to give last-mile electricity connectivity to about 40 million households by end of 2018.

**Table 1.4: Per Capita Electricity Consumption (CEA)**

Year	Per Capita Electricity Consumption (kWh)
2005-06	631.4
2006-07	671.9
2007-08	717.1
2008-09	733.5
2010-11	818.8
2011-12	883.63
2012-13	914.41
2013-14	957
2015-2016	1122

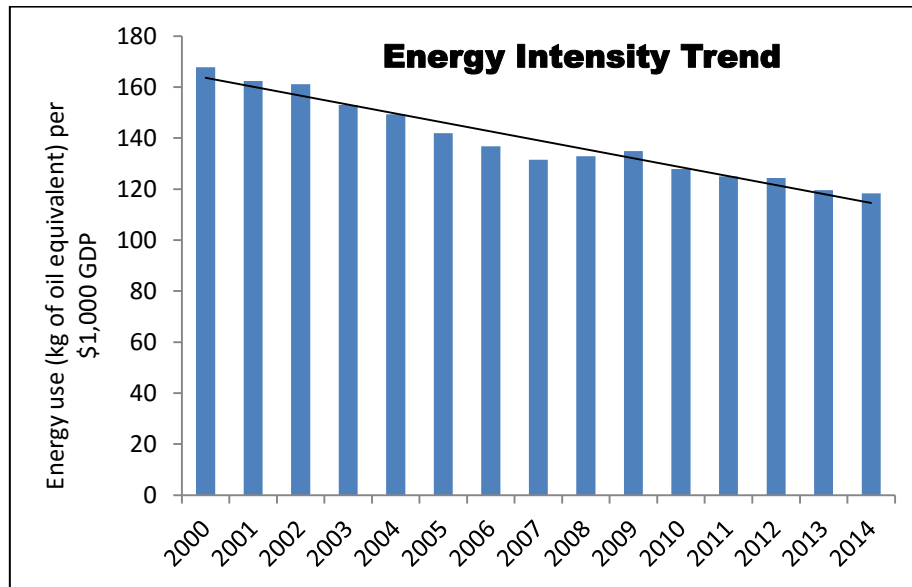
### Energy intensity

Energy intensity is an indication of how much energy is used to produce one unit of economic output. Lower ratio indicates that less energy is used to produce one unit of output. Unlike energy use per capita which describes only how much energy is being used, and provides no details as to how that energy is used, energy intensity clarifies how well energy infrastructure is performing and what it does for a person.

Energy Intensity is the ratio between energy supply and gross domestic product (GDP) measured at purchasing power parity at constant prices of 2011. The unit is energy use (kg of oil equivalent) per \$1,000 GDP (constant 2011 PPP). The trend in energy intensity is shown in Figure 1.17.

India stood at 0.122 koe/\$2005p as against world average of 0.144 koe/\$2005p (Enerdata 2017).

The energy intensity (at 2004/05 prices) decreased from 0.465 MJ per rupee in 2006/07 to 0.271 MJ per rupee in 2015/16 (MoSPI 2017).



**Figure 1.17 Energy Intensity Trend**

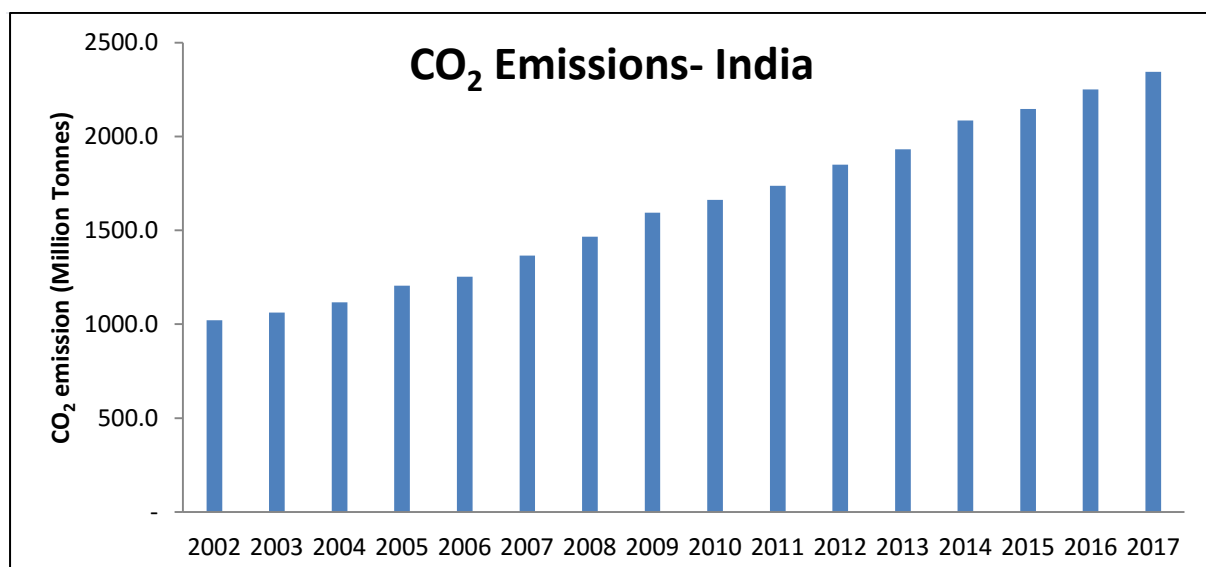
(Source: BP Statistical Review of World Energy)

## 1.9 Carbon-dioxide emissions

India's CO<sub>2</sub> emissions can be seen in two different perspectives. On per-capita basis, emissions are very low – 1.7 t CO<sub>2</sub>, which is 25% of China's and 10% of United States and even well below the global per capita average of 4.3 t CO<sub>2</sub>.

On volume basis, India is third largest country in terms of CO<sub>2</sub> emissions. The carbon dioxide emission in 2017 was 2344.2 Million tonnes of carbon dioxide which is 7% of world total emissions. The trend in CO<sub>2</sub> emissions over the last 15 years is shown in Figure 1.18.

Heavy use of coal and low power plants efficiencies are some of the reason for high carbon intensity of 0.791 kg CO<sub>2</sub>/kWh as against world average of 0.533 kg CO<sub>2</sub>/kWh.



**Figure 1.18: CO<sub>2</sub> Emissions Trend**

(Source: BP Statistical Review of World Energy)

## 1.10 Policy Interventions

### Integrated Energy Policy

The Government of India has adopted an integrated energy policy which aims to provide energy security to all its citizens through conventional as well as alternative sources of energy. Some of the policies adopted by the Indian Government are as follows.

- The Electricity Act, 2003 has given a thrust to distributed generation particularly in the context of rural electrification. The Act specifies distributed generation and supply through stand-alone conventional and renewable energy systems.
- The National Electricity Policy notified in 2005 recommends providing reliable rural electrification system; wherever conventional grid is not feasible, decentralized distributed generation facilities (using conventional or non-conventional sources of energy) together with local distribution network to be provided.
- Two specific schemes, the Rajiv Gandhi Grameen Vidyutikaran Yojna and the Remote Village Electrification Scheme, provide up to 90% capital subsidy for rural electrification projects using decentralized distributed generation options based on conventional and non-conventional fuels.

### Paris Agreement on Climatic Change

Conference of the Parties (COP 21) was held in Paris under the UN Body, UNFCCC in 2015. The agreement reaffirms the goal of keeping average warming below 2 degrees Celsius. India has submitted its Intended Nationally Determined Contributions (INDC) with plan, policies, measures, actions etc. to combat climatic change. Some of India's INDC commitments include the following:

- Propagate sustainable living
- Adopt climate friendly and cleaner path
- Reduce emission intensity of its GDP by 33 to 35 percent by 2030 from 2005 level.
- Generate 40 percent cumulative electric power generation from non-fossil fuel based resources by 2030.
- Support environmental initiatives (annually, 220 billion rupees of CSR money is to be spent.
- Voluntary carbon disclosure programme for private sector handled by Carbon Disclosure Project, India.
- National Solar Mission—20 GW to 100 GW by 2022.
- Nationwide Campaign for Energy Conservation—targets to save 10 % of energy consumption by 2018-2019
- Smart Cities Mission—by building a clean and sustainable environment.
- Green Highways (Plantation & Maintenance) Policy —140,000 km long “tree-line” along both sides of national highways.

- Faster Adoption and Manufacturing of Hybrid & Electric Vehicles.

### 1.11 Renewable Energy Thrust

Currently renewables account for around 20% of India's total installed capacity. With abundant natural resources for solar power, wind power, bio-energy and hydro power, the Government of India in 2015 set a target to achieve 175 GW of renewable energy by 2022). This target comprises 100 GW solar power, 60 GW wind power, 10 GW bio-energy, and 5 GW small hydro power (Figure 1.19).

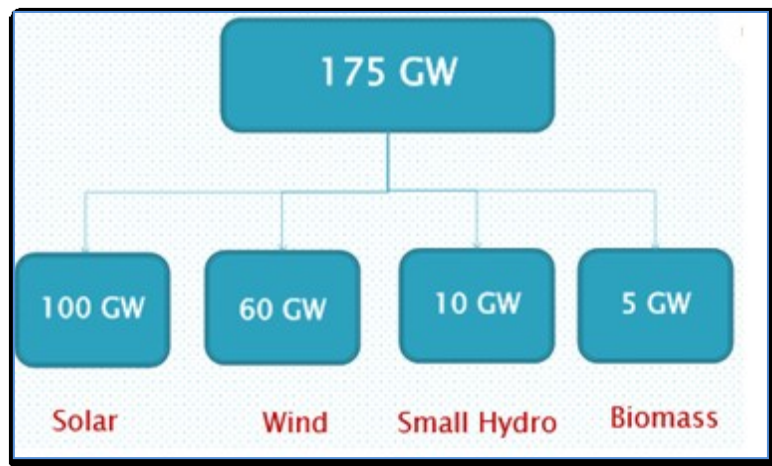


Figure 1.19: Break-up of Targeted Generation of 175 GW (MNRE)

The 100 GW break-up of solar power is shown in Figure 1.20. Of this, 40 GW has been targeted through grid-connected rooftop solar.

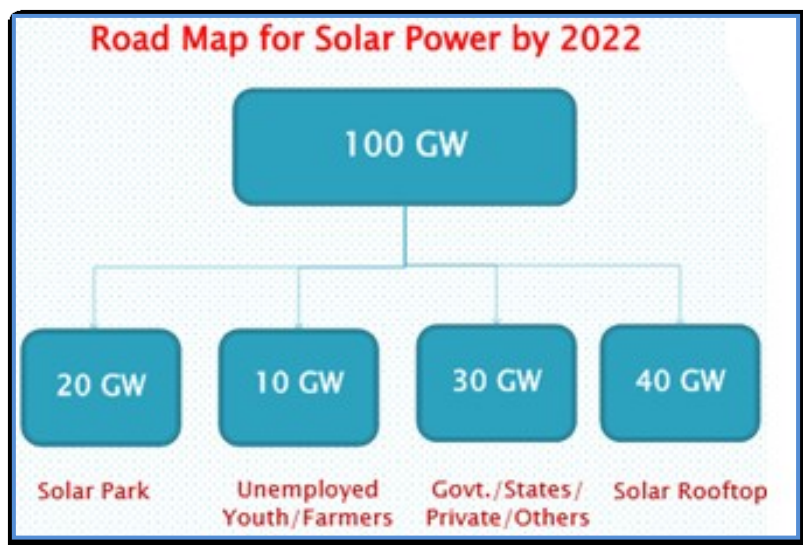


Figure 1.20: Road Map for Solar Power by 2022 (MNRE)

Few of the most important terms relevant to renewable energy are as follows:

### **Renewable Purchase Obligation ('RPO')**

Renewable Purchase Obligation (RPO) is the requirement set by the Central Electricity Regulatory Commission (CERC) for an obligated entity to purchase electricity from renewable energy sources or buy Renewable Energy Certificates.

Obligated entity generally means the distribution licensee, consumer owning the captive power plant (other than fossil fuel based cogeneration) and open access consumers (1 MW and above) who are mandated to fulfil the renewable power obligations under the respective State's legislation. If the distribution licensee is not able to produce renewable power or tie up procurement of renewable energy to meet the RPO target, it may plan to purchase RECs to meet its RPO target.

Under Renewable Purchase Obligation mechanism, each State has to meet 3% of its energy demand from solar sources, The Ministry of New and Renewable Energy (MNRE) is planning to raise the mandatory RPO requirement to 10.5%.

### **Renewable Energy Certificate (REC)**

It is a market based instrument created to promote renewable energy and facilitate renewable purchase obligation (RPO).

1 REC = 1 MWh of renewable electricity generated and injected into the grid.

REC can be traded only in the CERC approved power exchanges namely Indian Energy Exchange and Power Exchange of India. However, RE generators with existing PPAs are not eligible for REC mechanism.

### **Power Purchase Agreement (PPA)**

PPA is a legal contract between an electricity generator and a power purchaser. The power purchaser agrees to off-take the power generated by generator for a specified number of years (usually >10 years). The generator is thereby assured of getting the money back within the PPA period. It is during this time the power purchaser buys power. Central and State utility PPA contractual terms last for 25 years, whereas new Private PPAs are around 5–10 years.

Solar Developers are able to competitively price solar power for both public as well as private customers under the terms of the PPA. PPAs usually include terms of agreement i.e. details on interfacing and evacuation facilities, operation and maintenance, metering arrangements, scheduling of solar power, rate of energy including escalation rates, dispute settlement, billing and payment.

### **Feed-in Tariff**

A feed-in tariff (FIT) is a policy designed to promote the renewable energy resources. A feed-in tariff amounts to a guaranteed payment to homeowners (and other energy developers) for the electricity they produce. Feed-in tariff payments are for a preset amount

determined by State Electricity Regulatory Commissions (SERCs). Generally FIT payments are made over a period of 15 to 20 years.

The feed-in tariff mechanism is expected to apply towards solar projects with capacities less than 5 MWs and wind projects with capacities below 25 MWs.

### **Open Access**

Open Access enables heavy consumers with more than 1 MW connected load to buy cheap power from the open market. The concept is to allow the consumer to choose from a number of competitive power companies, rather than being forced to buy power from the local utility monopoly. It not only helps the industrial & commercial consumers by ensuring regular electricity supply at competitive rates but also enhances the business of power markets.

Open access helps consumers meet their Renewable Purchase Obligations (RPOs) as well. A consumer with bulk load can avail the benefits of green solar power by either purchasing through the rooftop solar installation in its premises or buying from an offsite solar farm under open access.

Open Access will ease the power shortage since a number of power producers like Solar energy companies can now transmit power from their solar parks to distant load centres. Once the consumers are given the choice to purchase power from the open market, it will automatically lead to competitive pricing of electricity making electricity price drop. Operators under open access have to incur various charges for using the grid. These charges can vary from state to state and are lower in states with stable grid and favourable regulatory regime.

Based on the location of the purchasing and selling entities, Open Access can be classified as follows:

**Inter-State Open Access:** In this, the purchasing and selling entities belong to different states and they have to follow Central Electricity Regulatory Commission (CERC) regulations.

**Intra-State Open Access:** As evident from the name, the purchasing and selling entities, in this case, belong to the same state. State Electricity Regulatory Commission (SERC) regulations apply.

The buyer and seller of electricity can opt for either **collective** or **bilateral** transactions.

In **collective** transaction, the trading of electricity is facilitated through exchanges with a very small fixed fee.

In case of **bilateral transaction**, a Power Purchase Agreement is signed between the seller and the consumer for buying power at mutually agreed tariff for predetermined number of years. Many of the leading solar players use such bilateral agreements for tariff determination with commercial and industrial clients.



Open Access rights in India are governed by **the Electricity Act 2003** which has laid down regulations for competition in the power market.

### **Incentives and Support**

There are many incentives provided to solar power development stated in both central and state solar policies. Central government incentives include the following:

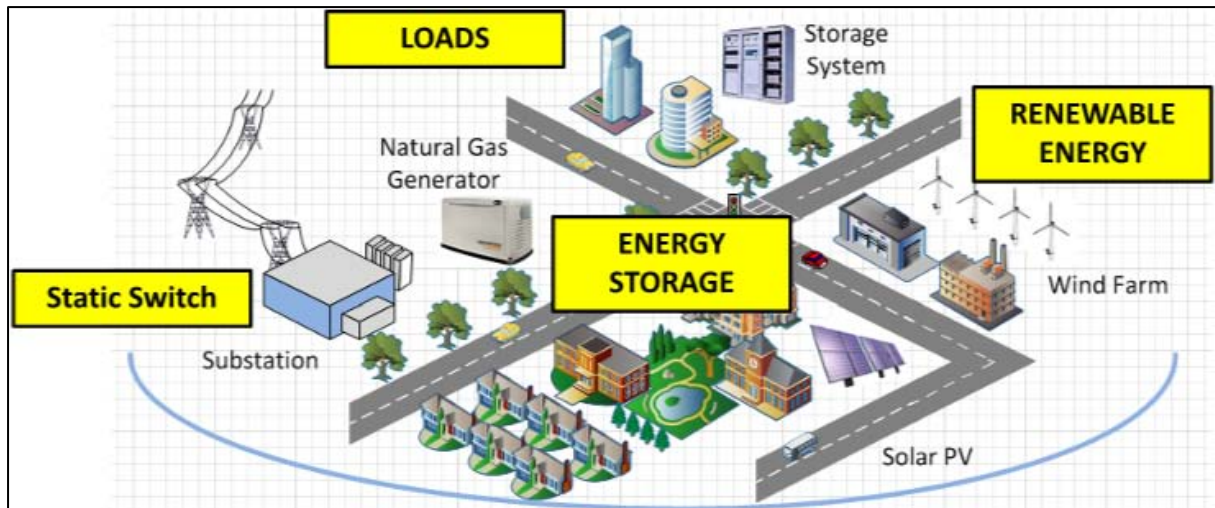
- Capital subsidy equivalent to 30% of the project cost for non-commercial rooftop PV systems.
- Income tax holidays and accelerated depreciation for commercial projects
- Concessional custom duties on solar equipment
- Limited financial support for solar park projects

### **1.12 Distributed Generation**

When energy is generated and distributed using small scale technologies closer to its end users, it is termed as Distributed Generation. These generations are based on the technologies, mainly renewable such as photovoltaic cells, wind turbines, micro hydro plants (Figure 1.21). Onsite decentralized power generation has many benefits over the centralized power generation systems, as it eliminates the costs associated with the transmission and distribution of power over long distances. These small scale technologies can yield power from 1 KW to as much as 100 MW.

When decentralized electricity generation takes place at local level using site specific energy sources serving a limited number of consumers, it is called Micro Grid. The sources can be individually connected to grid so that they can supply power to the grid when required or can be totally independent of the grid. When a source supplies power to the grid when required, the consumer becomes 'prosumer' i.e. a producer as well as consumer of electricity. This will help utilities to reduce the need for massive investments in building new high-voltage transmission lines to carry renewable power from far-off plants to towns and cities.

From customers view, micro grids is similar to traditional local voltage distribution networks not only providing their electricity needs, but also enhancing reliability, improving power quality by reducing voltage dips and resulting in lower cost of energy supply.



**Figure 1.21: Distributed Generation**

Micro energy grid (MEG) is a relatively small-scale localized energy network that includes load, a control system, and a set of energy resources, such as generators and energy storage devices. MEG can operate in a grid-connected mode where energy resources interact with the main electrical grid, or in an islanding mode where an MEG feeds its local loads without the use of the main electrical grid.

On-site decentralized power generation helps in reducing peak loads and hence better system management of the central grid. In typical Indian rural areas, smart micro-grids can provide clean, reliable, affordable, and scalable electrical power.

A key feature of a micro-grid is its ability to separate and isolate itself from the grid seamlessly during a utility grid disturbance with little or no disruption to the loads within the micro-grid. The micro-grid can automatically resynchronize itself when the utility grid returns to normal functioning, and reconnects itself to the grid seamlessly.

### Benefits of Distributed Generation

- No high peak load shortages
- Reduced transmission and distribution losses
- Linking remote and inaccessible areas
- Faster response to new power demands
- Improved supply reliability and power management

### Technologies for Distributed Generation

A decentralized generation system can include renewable as well as non-renewable energy sources. The decentralized generation technologies include, but are not limited to the following:

- Reciprocating Engines
- Micro turbines
- Gas turbines
- Fuel cells

- Photovoltaic (PV) cells
- Wind Turbines

### 1.13 Smart Cities

In India, about 31% of population living in urban areas contribute 63% of GDP. It is projected that by 2050, 70% of the population in India will be living in the cities. Cities are already facing problems such as high population, migration from rural areas, poor air quality, inadequate waste management, declining quality of life, power shortage, traffic jam, overburdened transport system and so on. In June 2015 the government launched the Smart City Mission, with the aim of developing 100 smart cities across India. Smart cities mission was conceived to find smarter solution to make cities sustainable i.e. meet the needs of future generation.

There is no agreed decision on what is a smart city. It is very specific to the city, for each city needs are different and so also the solutions. There is no one size fits all. The focus of smart cities depends upon the pressing needs of its citizens, and where greater opportunities for improvement lie. It also depends upon economic growth and quality of life. Hence, there are various definitions of a smart city. On such definition is as follows:

*“A smart city uses information and communications technology to enhance its liveability, workability, and sustainability.” - Smart Cities Council*

The main objective of a smart city is to provide a clean, safe and sustainable environment to live and work, by ensuring modern urban infrastructure and efficient use of resources. A smart city should be green, efficient and climate resilient. The pillars of a smart city are (a) core infrastructure (b) quality of life (c) sustainable environment and (d) smart solution.

A smart city uses available technologies to improve living conditions through access to information about parameters that affect its inhabitants. These parameters include energy consumption, utilities, transportation, air quality, water quality, waste management, health-related issues, education levels, employment and any other relevant information that could potentially benefit the population. Thus reaching the status of a fully autonomous smart city is a long-term goal.

A city aspiring to become smart has to formulate its unique vision, mission and plan reflecting its needs and aspirations depending upon the local context, resources and priorities of its citizens. These may include even basic needs for example open public spaces, more transit options, clean water, E-Governance, transparency etc. Citizens should be engaged in the process. Local leaders may also customize ideas from around the world to harness technology.

Two types of cities are being proposed (1) green field project i.e. city built from scratch (example is Dholera, Gujarat), and (2) exiting city retrofitted with latest technology.

Centre has allocated a fund of INR 48000 Crores for this purpose. Each city would be funded INR 100 crores for 5 years. An equal matching amount is to be contributed jointly by the State and Urban Local Governments. Other sources of funding include infrastructure financing institutions, external commercial borrowing, financial institutions, banks lending institutions, direct investments and even other countries.

Key energy management components of smart cities include the following:

- Distributed generation
- Smart grid
- Smart meters
- Demand response
- Energy storage
- Micro grid and virtual power plant
- Rooftop solar initiatives
- Smart LED
- Smart street lighting
- Energy harvesting
- Energy-efficient and adaptive construction designs, technologies and standards
- Smart equipment and appliances
- Advanced HVAC
- Building retrofits

One example of energy-related application in smart cities is the popular ‘Smart Street Lighting’. Street lighting projects are popular because of their enormous potential to deliver a quick return on investment. Smart street lights can save 50% to 70% of energy cost by dimming lighting when activity is low. Networked LED lights can provide not only energy savings but information about outages or other anomalies in the lighting network. These lights are interconnected and also communicate with video cameras, parking sensors, environmental sensors, weather sensors.

#### **1.14 Smart Transportation**

As per a World Bank study, by 2031, some 600 million people are expected to live in India's cities. However, only about 20 Indian cities with populations over 500,000 have any kind of organized public transport systems. In fact, the share of public transport in large Indian cities is decreasing over the years. Furthermore, India's accident and fatality rates are among the highest in the world, mainly affecting the poor and vulnerable who do not have their own means of transportation.

Smart transportation includes the use of several technologies, such as car navigation; traffic signal control systems; container management systems; automatic number plate recognition or speed cameras to monitor vehicle activities, such as security CCTV systems; and to more advanced applications that integrate live data and feedback from a number of sources.

Some of the technologies relevant for Smart Transportation include the following:

**Bicycle sharing system:** A bicycle sharing system, public bicycle system, or bike share scheme, is a service in which bicycles are made available for shared use to individuals on a very short-term basis. For many systems, smart phone mapping apps show nearby stations, how many bikes and how many open docks are available at each station, increasing convenience and green commuting for commuters.

**Dynamic carpooling/car sharing:** Carpooling applications link drivers and passengers in real-time, thus enabling dynamic carpooling. Drivers wishing to profit from their journeys can find people situated on the same route via a smartphone app and vice versa.

**GPS-based tracking and route information of public transport:** Advanced vehicle tracking solutions enhance operations and optimise public transportation and ridership. These solutions offer real-time GPS tracking from mobile devices thereby increasing the reliability of public transportation.

**Road user charging:** Road user charges are direct charges levied for the use of roads, including road tolls, distance or time-based fees, congestion charges and charges designed to discourage use of certain classes of vehicles, fuel sources or more polluting vehicles. These charges help to reduce peak hour travel and associated traffic congestion or other social and environmental negative impacts associated with road travel such as air pollution, greenhouse gas emissions.

**Single fare card:** Single fare card for fare payment for the various participating public transportation systems. The cards can be recharged by mobile applications/internet/retail outlets. The same cards could also be used for street parking.

**Smart parking:** A smart parking leverages parking sensors, cameras, smart parking solution to provide efficient use of on street and off street parking spaces.

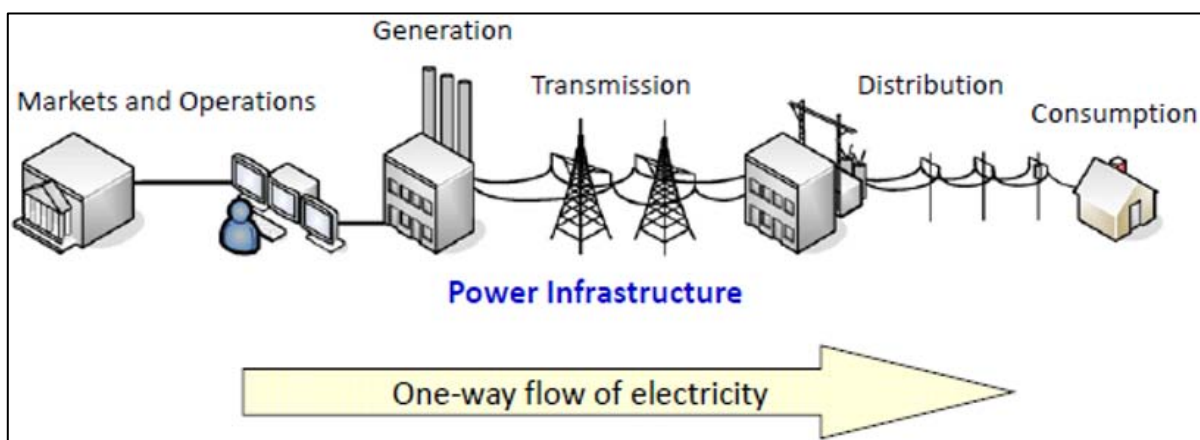
**Smart toll:** Smart toll leverages technology like number plate detection, RFID (Radio Frequency Identification), etc. to charge toll fees to user account so that vehicles do not have to wait at toll gates on national highway.

**Smart traffic lights:** Smart traffic lights leverages technology to sense traffic condition and tune traffic lights which enable smooth flow of traffic.

**Electric vehicles:** Support electricity and renewable energy operated cars with the required infrastructure, such as plug-in infrastructure for Electric Vehicles (EVs) and integration with grid.

## 1.15 Smart Grid

India's energy demand is expected to increase three times in the coming 10 years and two-thirds of the energy would be carried by the grid. The traditional grid has been a centralized unidirectional system with transmission, distribution, and demand-driven control as shown in Figure 1.22. To meet ever-increasing demand, more power stations were installed. In some places, the supply of electricity, especially at peak demand time, could not meet the demand, resulting in poor quality of service. With increasing use of electronics and communication equipment, customers are demanding higher quality and reliable power. Therefore the existing grid is inadequate and the issues faced include power shortage, poor access to electricity in rural areas, high T&D losses, insufficient power consumption, poor reliability and power theft.



**Figure 1.22: Conventional Grid**

With increasing use of renewable energy sources, major shift from centralized grid topology to a distributed grid with power being both generated and consumed in the same place is taking place. There is a need for more sophisticated control systems to facilitate renewable energy integration with the main electrical grid.

With increasing penetration of distributed generation, the direction of power flow is also changing from unidirectional to bidirectional, which raises safety and reliability issues. In this context, smart grid is being proposed as the solution to meet increasing demands for stable, reliable and uninterrupted power supply. With the smart grid vision, generation, transmission, and distribution infrastructure will be better able to handle *bidirectional* power flows and allow for flexible network topology.

A Smart Grid is one that incorporates information and communication technology into every aspect of electricity generation, delivery and consumption in order to minimize environmental impact, enhance markets, improve reliability and service, reduce costs and improve efficiency.

**Electric Power Research Institute (EPRI)**

Smart Grid is a power system capable of two-way communication between all the entities of the network: generation, transmission, distribution and the consumers. The aim of smart grid is to provide real-time monitoring and control, and thus improving the overall efficiency of the entire system apart from inclusion of distributed energy resources e.g. renewable energy into the system.

### **Technologies for smart Grid**

To build an SEG, several technologies need to be developed and implemented covering generation, transmission, and distribution systems, as well as consumer appliances and equipment. These include advanced sensing and measurement, advanced metering infrastructure (AMI), Home Area Network (HAN) communication, and phasor measurement units (PMU).

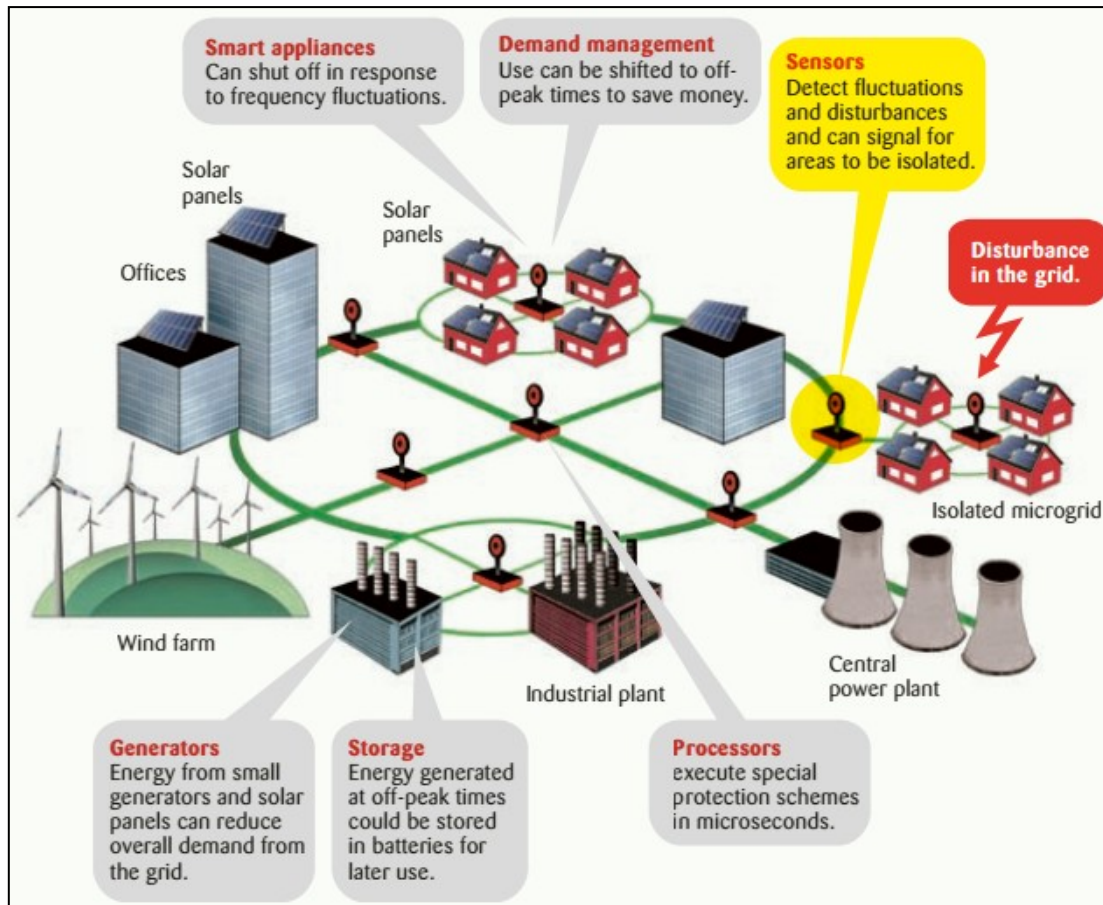
### **Benefits of Smart Grid**

Utilities are able to anticipate, detect and respond to system problem faster with technologies such as embedded sensors and automated controls. These technologies facilitate self-healing and can automatically avoid or at least mitigate power outages, power quality problems, and service disruptions, thereby providing consumers with a more reliable energy system.

Power systems will be able to predict availability of renewable energy sources so as to utilize them efficiently. New technologies will contribute to better demand response and load control, allowing utilities to lower costs by shifting loads to less expensive generation during peak demand. The schematic representation of smart grid with benefits is shown in Figure 1.23.

With smart grid, meters will evolve from just monitoring loads into smart meters, where meters could store how electricity was used by customers at different times of the day. This allows continuous communications to facilitate monitoring in real time. This will enable consumers to better manage energy consumption by adjusting consumption and usage patterns to reduce costs. With modern demand response-aware devices, such as modern air conditioners and refrigerators, duty cycle can be automatically adjusted to avoid running during grid peaking conditions.

<p>The National Tariff Policy 2016 had mandated that consumers with monthly consumption of over 500 units (or kilowatt hour) had to be switched to smart meters (internet-enabled meters).</p>
--



**Figure 1.23: Schematic Representation of Smart Grid.**

Government is investing highly in upgrading the existing grid to smart grid through various programs like Revised Accelerated Power Development and Reform Program (RAPDRP) and other schemes such as Jawaharlal Nehru National Solar Mission, Rajiv Gandhi Grameen Vidyutikaran Yojana (RGGVY).

### 1.16 Internet of Things (IoT)

Internet revolution began with connecting people to information and then people to people. The next phase involves connecting devices to devices. Even if seven billion people in the planet are connected, this will be insignificant compared with connecting 25 billion devices as estimated by 2020. We are rapidly evolving from an Internet of people to a “The Internet of Things”. The IoT is a technology digitizing the physical world.

In the most general form, the IoT is a world where everything and everyone is connected together. Additionally, the physical objects may also make decisions about the collected, processed, and exchanged information, as well as take actions to control the physical objects and the environment in which they are embedded.

The Internet of Things (IoT) is defined as a collection of physical objects (i.e., “things”) and their interconnected communication networks that allow the physical objects to gather, store,



process, and exchange information. The physical objects can be almost anything, from the smallest devices or products to the largest systems.

The Internet of Things (IoT) has been successfully adopted in many commercial applications. We are already aware of wearable applications which can track and display personalized data such as calories burnt, heart rate, sleep hours etc. that result in improving one's health and fitness.

The capabilities that enable the physical objects to participate in the IoT are usually composed of an assemblage of different types of advanced technologies including electronics, sensors, actuators, and software. These capabilities are either connected to or integrated into conventional products and systems such commercial building control, HVAC appliances, vehicles, power generators etc.

There are several important elements that are needed in the implementation of the IoT. The first is the communication networks that enable devices, perhaps using different operating systems, to communicate with one another. The second is the large and inexpensive information storage and processing power available in modern integrated circuits. The third is the inexpensive and unobtrusive devices that can sense and actuate to control the things and/or environment in which the things are embedded.

Micro miniature devices that can sense and actuate are commonly called "MEMS" in the semiconductor industry, which is an acronym for "Micro-Electro-Mechanical Systems." MEMS is an emerging technology that is an important enabler for the IoT.

Few potential applications for using IoT technology include the following:

**Smart Homes or Buildings:** Sensors and actuators can monitor the energy consumption and take appropriate action such as switching on/off lighting and cooling tasks. The smart home appliances are available with connectivity features that allow them to be automated to benefit from smart metering and variable tariffs.

**Transportation:** Sensors in vehicles can monitor various aspects related to the efficiency of the transport: tire pressure, fuel consumption, location, and speed. Another example is smart traffic light sensors which could stop or slow down approaching traffic to avoid traffic jams or accidents when multiple braking vehicles are detected.

**Smart grid:** Smart meters will collect and relay information on electricity consumption, enabling dynamic pricing based on actual electricity supply and demand. Based on current price and local energy needs, the system can switch on or off appliances that need a lot of power, or it could switch them automatically to different power sources such as solar and wind.

Industrial Applications: An IoT-based real-time monitoring system helps to achieve optimum use of energy. Pumping Flow and pressure can be regulated and controlled using sensors and software in real-time to optimize performance and efficiency. IoT-based monitoring can also be setup for the following:

- Motors
- Fans
- Chillers
- Air compressors
- Boilers
- DG sets

### 1.17 Industry 4.0

A typical industry as part of its operation generates lot of data which it does not use. Since energy management is not normally part of core business process, energy related data is not effectively used. From the technology point of view, the growth of sensor networks and Internet of Things has given us the tools to effectively monitor and adjust all aspects of data in real time.

With Industry (Energy) 4.0 projects, energy data is incorporated into factory management. Energy consumption along with production and costs can be tracked down to the level of individual batches for specific energy consumption and analysis of data can be performed and reports can be generated. Data analytics can be performed to optimize production, increase efficiency, flexibility and enhance quality in real-time.

The fourth Industrial revolution or Industry 4.0 as it is well-known is broader than the IoT, encompassing technologies such as big data analytics, machine learning, and additive manufacturing (3-D printing).

Industry 4.0 is enabled by following technologies that integrate the digital and real worlds:

- The Internet of Things (IoT): Connecting more and more systems, devices, sensors, assets and people through networks ranging from wireless, low-power wide-area networks to wired high-capacity networks
- Mobile solutions: Including smartphones, tablets, wearable sensors and smart glasses
- Cloud computing: Including low-cost processing and data storage solutions
- Cyber-physical systems (CPS): Monitoring and controlling physical processes using sensors, actuators and processors, based on digital models of the physical world
- Big data analytics and business intelligence: Turning data into actionable insights, which include early warning algorithms, predictive models, decision support, workflows and dashboards
- Advanced manufacturing technologies: robotics and 3D printing.

## 2. PERFORM, ACHIEVE AND TRADE (PAT)

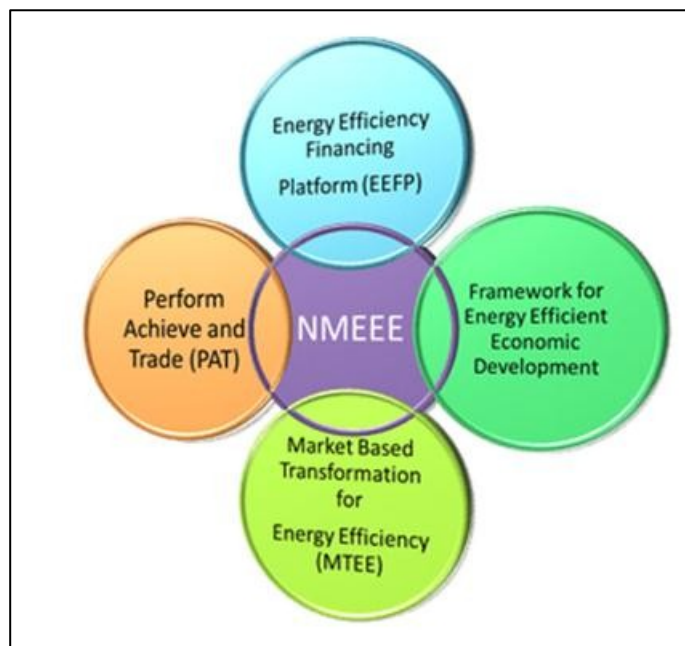
### 2.1 PAT Genesis

National Mission on Enhanced Energy Efficiency (NMEEE) is one of the eight missions which formed India's National Action Plan on Climate Change (NAPCC). The objective of NMEEE is to trigger energy efficiency opportunities through market based approach using various instruments as shown in Figure 2.1. One of the key instruments of NMEEE is Perform, Achieve and Trade (PAT). PAT is a regulatory instrument to reduce specific energy consumption in energy intensive industries, with market based approach to enhance the cost effectiveness through certification of excess energy saving that can be traded.

### Objectives of NMEEE

The National Mission on Enhanced Energy Efficiency mandates following objectives;

- A market based mechanism to enhance cost effectiveness of improvements in energy efficiency in energy-intensive large industries and facilities, through certification of energy savings that could be traded. (Perform Achieve and Trade)
- Accelerating the shift to energy efficient appliances in designated sectors through innovative measures to make the products more affordable. (Market Transformation for Energy Efficiency)



**Figure 2.1: Components of NMEEE**

- Creation of mechanisms that would help finance demand side management programmes in all sectors by capturing future energy savings. (Energy Efficiency Financing Platform)
- Developing fiscal instruments to promote energy efficiency (Framework for Energy Efficient Economic Development) Market-based approaches to unlock energy efficiency opportunities, estimated to be about Rs. 74,000 crores

India has submitted its **Intended Nationally Determined Contribution (INDC)** to the United Nations Framework Convention on Climate Change (UNFCCC) targets to lower the emission

intensity of its GDP by 33% to 35% by 2030 below 2005 levels. The goal is to reduce energy intensity by 7% between 2016 and 2019. PAT is one of the most effective ways to achieve and meet India's INDC commitments.

## 2.2 Overview of PAT

PAT mandates specific energy efficiency improvements for the most energy intensive industries. The scheme is based on the wide variations in specific energy consumptions (baseline SECs) of different units in each notified sector. The units in terms of SECs range from among the best in the world to some of the most inefficient units.

The scheme proposes improvements in the specific energy consumption of each unit. The specific energy consumption reduction (target SEC) is prescribed for each unit depending upon its current energy efficiency level; more efficient unit will have a lower reduction target than less efficient unit in the same sector.

The first cycle of PAT (PAT-I) was completed in March 2015 covering eight energy intensive sectors namely thermal power stations, iron and steel plants, cement, fertilizer, textile, pulp and paper, chlor alkali and aluminium. After rigorous verification of energy performances, the units surpassing their targets were identified for award of Energy Saving Certificates (1 ESCerts = 1 MTOE (Metric Tonne of Oil Equivalent) based on their achieved SEC. On the other hand, those units that have not met their target SECs are required to purchase ESCerts for meeting compliance besides paying a penalty for not meeting the target. The concept of target, compliance, ESCerts, and penalty is illustrated in Figure 2.2. ESCert can be traded in two exchanges namely Indian Energy Exchange (IEX) and Power Exchange of India (PXIL).

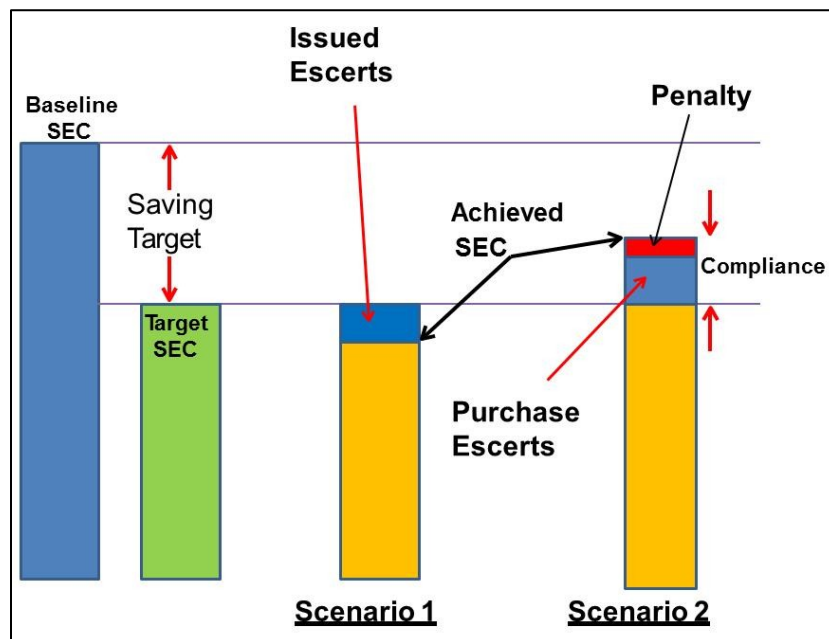


Figure 2.2: Concept of Target, Compliance, ESCerts and Penalty

## 2.3 PAT Concept

The concept of PAT scheme for a complete cycle is presented in the Figure 2.3.

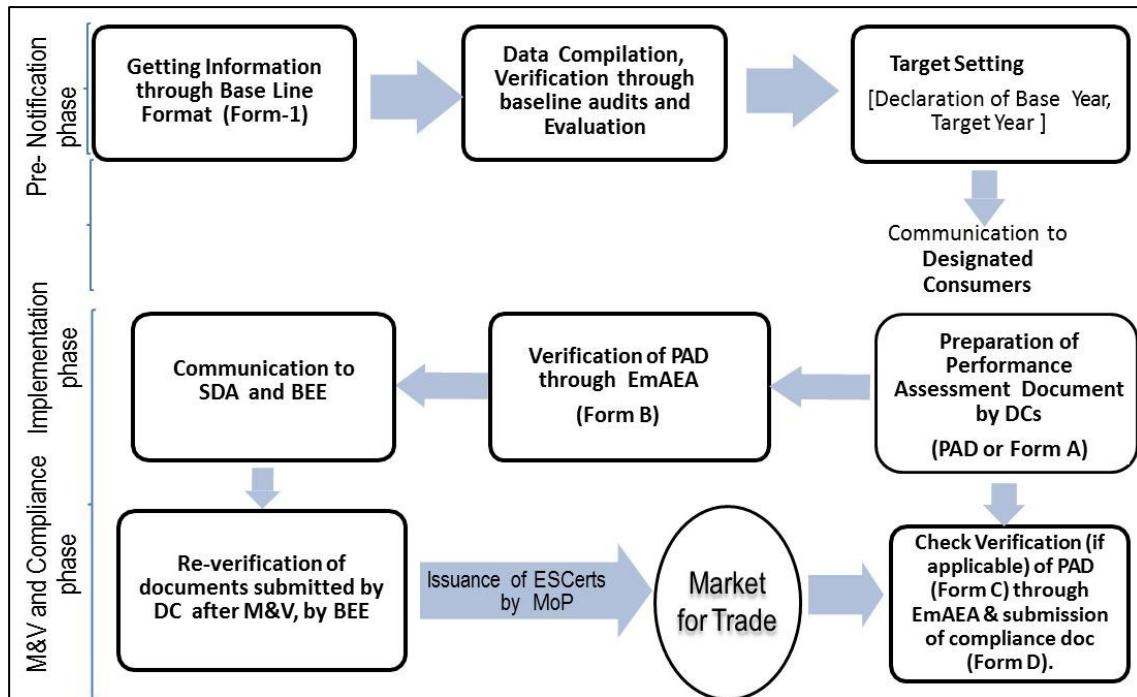
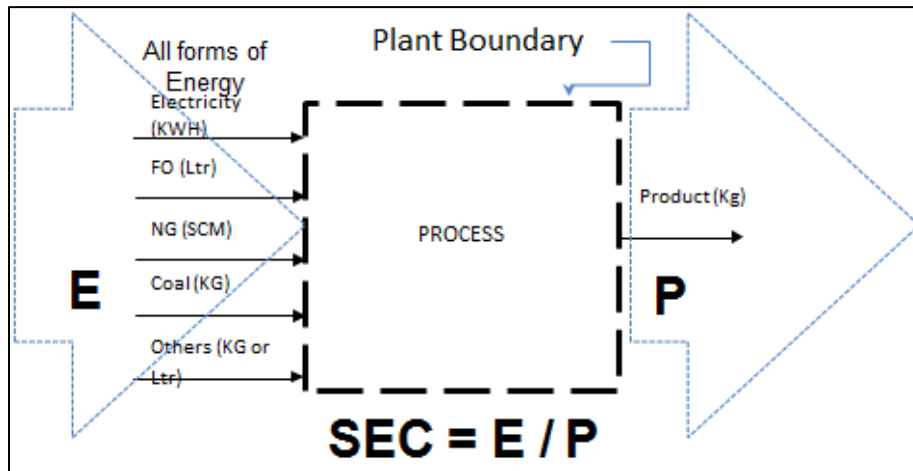


Figure 2.3: PAT Concept

## 2.4 Baseline Assessment

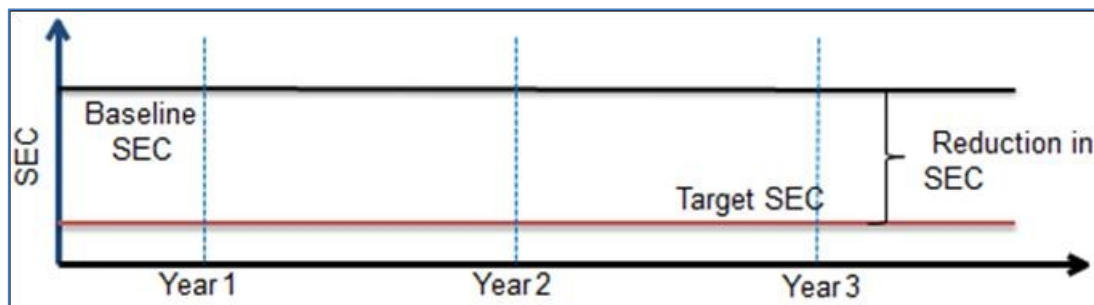
Once a unit is identified as a Designated Consumer (DC) based on its threshold energy consumption, PAT study begins with assessment of baseline specific energy consumption (SEC) using Form-1. SEC is calculated on a Gate-to-Gate (GtG) concept after determining the plant boundary as shown in the Figure 2.4.

Energy consumption and production details are collected in sector specific pro-forma from DCs. The baseline is reviewed and evaluated by BEE in consultation with relevant sector-specific technical committee, and target SEC along with target year is notified and communicated to DCs. This information is gazetted and released in BEE website.



**Figure 2.4: SEC Assessment Using Gate-to-Gate Approach**

Within three months of the issue of notification of target SEC, the concerned DC shall submit a scheme to State Designated Agency (SDA) with a copy to BEE which shall include action plan proposing brief description of energy saving measures to comply with energy consumption norms and standard by the target year, estimated cost of each identified energy saving measure and implementation plan to achieve energy consumption Norms and Standards. A PAT cycle is three years and at end of the third year, target SEC will be verified by accredited energy auditors and reported for reduction in specific energy consumption as shown in Figure 2.5.



**Figure 2.5: Reductions in SEC**

## 2.5 Monitoring and Verification

Monitoring, reporting and verification is carried out to ensure effective and credible assessment of energy efficiency achieved by DCs. Specific energy consumption in the baseline and assessment year is verified. The verification involves independent evaluation of each activity a DC had taken to comply with energy reduction targets. The accredited energy auditing firm empanelled with BEE shall perform the Monitoring and Verification of the DCs and shall submit a report on the same to SDA with a copy to BEE

### **Normalization**

Normalization is a process of rationalization of the energy and production data considering the impact of quantifiable external variables that are beyond the control of the DCs. This is

to ensure that DCs are not placed in a position of advantage or disadvantage when target scenario is compared to baseline scenario. Authentic and relevant documents should be submitted by DC to support normalization. Data used for normalization should be available for baseline as well as target (assessment) year. A list of typical normalization factors (internal and external factors) are listed as follows:

#### **Internal Factors for Normalization**

- Capacity utilization
- Product mix & intermediary product
- Fuel mix (e.g. Pet coke utilization in kiln)
- Power mix (imported & exported from/ to the grid and self-generation from the captive power plant)
- Fuel quality in CPP
- Low PLF in CPP
- Raw material quality
- Biomass/Alternate fuel unavailability
- Addition of new line/Unit (In process & power generation)
- Renewable energy

#### **External Factors for Normalization**

- Grid failure/Breakdown (Grid not synchronized with CPP)
- Natural disaster (flood, earthquake etc.)
- Major change in Government policy (affecting plant process system)
- Environmental concerns (additional environmental equipment requirement due to major change in government policy on environmental requirements)
- Unforeseen circumstances (labour strike/lockouts/social unrest/riots)

#### **Normalization Documents and M&V Guidelines**

Normalization document for each sector is available with BEE for free reference and downloads in BEE website for the benefit of DCs.

#### ***Process of verification***

The verification involves review of Sector Specific Pro-forma, Form 1 and Summary Sheet. The following forms are to be submitted by the concerned DC and EmAEA.

- Sector Specific Pro-Forma and Form I by DC
- Performance Assessment Documents (Form A) by DC
- Certificate of Verification (Form B) by EmEA
- Compliance of Energy Consumption Norms Document (Form D) by DC

#### **Sector Specific Pro-forma**

The Sector Specific Pro-forma covers following aspects of GtG information:

- Production and capacity utilisation details
- Section-wise details of various products

- Electricity and renewable energy consumption
- Power generation (DG/GG/GT/STG/Cogeneration/WHR)
- Fuel consumption (Solid/Liquid/Gas/Biomass, and others)
- Heat rate of different power sources and coal quality
- Miscellaneous data for normalisation
- Installation of additional equipment to protect the environment
- Project activity details
- Summary sheet
- Normalisation calculation sheets

DC enters production, energy, and normalization factors under equivalent conditions for baseline and assessment years. GtG SEC is automatically calculated and displayed in a summary sheet.

### **Form 1**

Form 1 contains details of Information regarding total energy consumed, production, and specific energy consumption per unit of production. The Designated Consumers themselves have to update the information on the PATNet portal maintained by BEE. Form 1 is to be submitted annually within 3 months before the completion of the financial year (i.e. 31<sup>st</sup> March).

### **Form A**

Form A is the **Performance Assessment Document (PAD)** prepared by the DCs in the assessment year for monitoring and verification.

### **Form B**

Form B is the **certification of verification** by EmAEA on completion of M&V study in the assessment year.

### **Form C**

Form C is the **certification of cross-verification** by EmAEA.

### **Other Forms to be submitted by DC under EC Act**

**Form–2:** Details of energy savings measures recommended in mandatory energy audit report. This will be submitted to the SDA with a copy to BEE within specified period of time.

**Form–3:** Details of energy efficiency improvement measures implemented, investment made and savings in energy achieved and progress made. This will be will be submitted to SDA with a copy to BEE within specified period of time.

### ***Verification Report***

The DC shall submit final verification report prepared by EmAEA enclosing verified annually submitted Form 1, Sector Specific Pro-forma, Form A (Performance Assessment



Document), Form B, along with related authentic supporting documents.

Timelines and activities for a PAT cycle are shown in the Table 2.1

**Table 2.1: Timelines and Activities for a PAT Cycle**

Activity	Time Line	Description	Activity by	Where
Action plan submission	3 months	Within 3 month from Notification	DC	SDA/BEE
Form 1 submission	3 months	Yearly submission of Form 1 within 3 months from last financial year	DC	SDA/BEE
Form A, Form B along with others documents	4 months	Within 4 month from conclusion of target year	DC	SDA/BEE
Submission of Form A, Form B with SDA comments	45 days	Within 45 days of the last date of submission of Form A	SDA	BEE
Recommendation of Issuance /entitlement to purchase ESCerts to MoP, GOI	Two months	Within two months from the date of the receipt of the comments from SDA	BEE	MoP
Issuance of ESCerts by MoP	45 Days	Within 45 days from the date of the recommendation of Escerts from BEE	MoP	
Form D Submission	One month	After 1 month from the completion of trading	DC	SDA/BEE

### ***Check-points for EmAEA***

The EmAEA shall carryout the following as part of monitoring and verification activities:

- Whether baseline production and energy related data are entered correctly in sector specific Pro-Forma as per approved baseline report.
- Whether authentic supporting primary and secondary sources of data are available
- Whether site visits, interviews with relevant personnel are supporting the documented findings
- Whether formulas and calculations are correctly applied in determining energy savings.
- Whether same boundary is considered for the entire PAT cycle including target year as finalized for baseline year in the final baseline report (the plant boundary in the target year should be same as established in the baseline year).

The SEC calculation methodology as devised in the sector specific Pro-Forma shall be considered. For computing gate-to-gate SEC, the plant boundary is defined such that total

energy input and defined product output is fully represented. Typically, entire plant is included excepting housing colony, residential complex, and transportation systems outside the boundary. Similarly, mining operations in the case of iron and steel, aluminium, and cement sectors are not considered under the plant boundary.

The baseline verified data shall be considered as the final data to be filled in the Sector Specific Pro-forma. In case of any typographical or factual error in the baseline data, the same shall be taken into account for preparing corrected versions during the verification, subject to availability of authentic data made available by the DC. The corrected data is taken into account while preparing verification certificate.

The various energy saving projects in quarterly, yearly, and end-of-cycle internal data reports prepared by the designated consumer is verified. The review covers measures adopted for energy conservation, quantum of energy saved, and investment made by the designated consumer during the relevant PAT cycle.

The data submitted for verification and other figure for SEC calculation should match with the plants' declared production and consumption figures as per the statutory financial audit declared in the statutory annual report.

Finally verification report containing summary of verification process, results of assessment and unbiased opinion along with supporting documents is prepared.

## 2.6 Certification of Energy Savings

It is the process of certifying the verification report or the check-verification report by the Empanelled Accredited Energy Auditor (EmEA) to the effect that the entitlement of energy saving certificate is quantified accurately in relation to compliance with energy consumption norms and standards by the designated consumer during the target year. The report is reviewed by BEE before recommending the energy savings. The procedure for issuing of ESCerts is as follows:

- Central Government—after receiving recommendation from Bureau (BEE) – issue ESCerts of desired value to DC within 45 days.
- ESCerts are issued in electronic form
- ESCerts issued in current cycle is valid till compliance period of next cycle.
- DCs who have been issued energy savings certificates may sell them through the power exchange.
- ESCerts purchased by DC for compliance shall after their submission to Bureau stand expired.

### ***ESCerts Determination***

ESCerts is issued to the eligible DC based on the following criteria:

$$\text{No. of ESCerts} = \text{Production in Baseline Year} \times (\text{SEC Base Year} - \text{SEC Target Year})$$

**Sample Calculation:**

Baseline year: 2014-15

Baseline SEC = 10 toe/unit of production

Baseline production = 10000 units

Target = 4% reduction in baseline SEC

Baseline SEC = 9.6 toe/unit of production

If achieved SEC = 9.8 toe/unit (unit has to buy 2000 EsCerts equivalent to 2000 (-) toe

If achieved SEC – 9.4 toe/unit (unit is awarded 2000 EsCerts equivalent to 2000 toe

**2.7 Trading of ESCerts**

For the trading of ESCerts, Central Electricity Regulatory Commission (CERC) is the Market Regulator and BEE is the Administrator. Power System Operation Corporation Limited (POSOCO) has been designated the role of Registry for Trading of ESCerts. Trading of ESCerts takes place in two Power Exchanges i.e. IEX and PXIL.

The energy savings certificates (ESCerts) are being issued only in electronic form. The value of one energy savings certificate shall be equal to one metric tonne of oil equivalent of energy consumed. For trading of ESCerts no floor price or forbearance price has been defined as the price of ESCerts is left to be discovered at the power exchanges.

Floor prices are lower bounds on price which can guarantee a minimum rate of return while Forbearance prices are upper bounds which can lead to prices going very high and consequently may burden consumers.

ESCerts shall be bought by DCs for compliance only, and after submission to BEE for meeting the compliance it will stand expired. DCs can buy the ESCerts upto or more than their compliance whereas seller DCs cannot buy ESCerts. DCs to whom the ESCerts are issued can sell them at Power exchanges and balance ESCerts can be used for meeting their compliance of next PAT cycle or be sold to any other DC for the compliance within the validity period. The validity period for ESCerts issued during current cycle is till the completion of the compliance period of respective DC's next cycle.

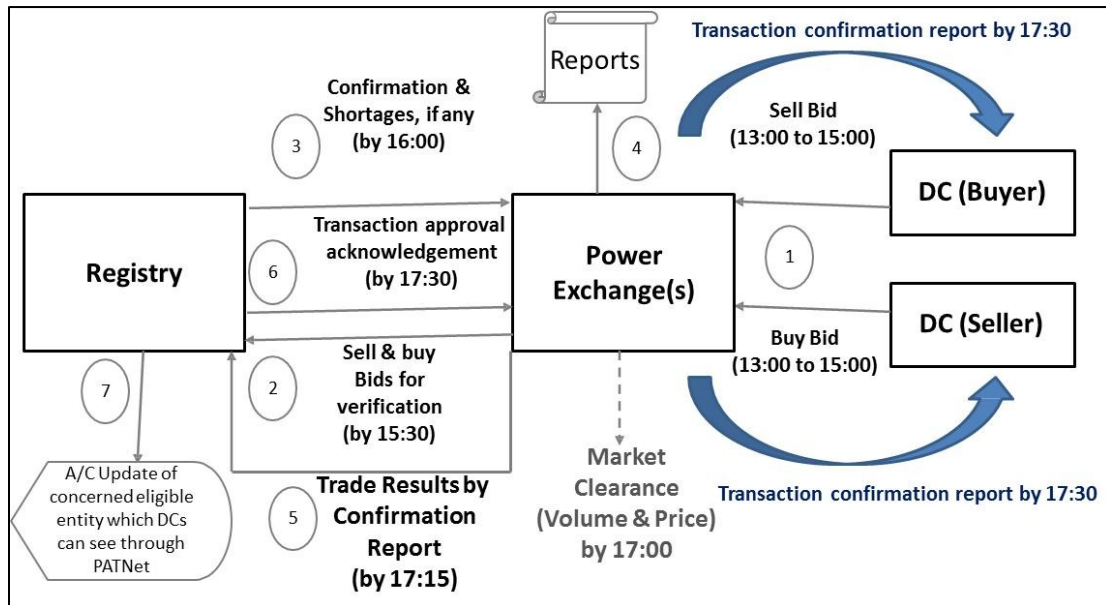
**Banking of ESCerts is allowed; ESCerts issued in any PAT Cycle remain valid till the compliance period of the next immediate cycle.**

CERC has issued the Procedure for Transaction of Energy Savings Certificates (ESCerts). The key points are as follows:

- a) Roles & responsibilities of Administrator, Registry, CERC and Power exchanges are defined.

- b) Market price of ESCerts shall be discovered through bidding at power exchanges i.e. through closed double-sided uniform price auction.
- c) Interested DCs to whom ESCerts have been either issued or are entitled to purchase by Ministry of Power (MoP) have to first register themselves with 'Registry' i.e. POSOCO to become eligible entity.
- d) For trading in Power exchanges, DCs have to get themselves registered with any of the Power exchanges.

The process flow for trading of ESCerts is illustrated in Figure 2.6.



**Figure 2.6: Process Flow for ESCerts Trading**

For trading of ESCerts, CERC approved the following fee structure:

- One time registration fee of Rs.15000/- for eligible entity
- ESCerts fee at the rate of Rs.5/- per ESCert for DCs issued with ESCerts
- Taxes and duties as applicable (GST @ 18%)

### Stakeholders for ESCerts Trading

#### **Registry**

Registry is the agency designated by Government of India in the Ministry of Power to perform such functions as defined in these regulations with respect to ESCerts. National Load Despatch Centre (NLDC) operating under Power System Operation Corporation Limited (POSOCO) is the Registry for ESCerts. The roles of Registry include the following:

- Assistance in registrations process of ESCerts including crediting of ESCerts to DCs.
- Collection of fees and charges, as approved by the commission in consultation with Bureau for the purpose of meeting the cost and expense towards the management of Registry and software platform.

- Management of ESCerts trading/exchange.
- Coordination and information dissemination with DCs, Power Exchanges, BEE and Commission.
- Assistance in development of IT platform along with guidance on hardware infrastructure for maintaining database of ESCerts and records of trading of ESCerts.

### **Power Exchanges**

The roles of Power Exchanges include the following:

- Formulate Rules and Bye Laws for Transaction of ESCerts on PX .
- Develop IT Platform compatible with the PAT-Net portal and D-CRM for online transaction (trading of ESCerts).
- Permit trading of ESCerts only to the Eligible Entities.
- Send reports for Transaction confirmation pay-in and payout for Executed Transaction.
- Issue Purchase Certificate to the Buyers.
- Display ESCerts demand supply curves on the website

Exchange of ESCerts shall be in compliance with the rules and bye laws of respective Power Exchanges. Before trading, all eligible entities who intend to participate in the exchange of ESCerts shall register themselves with the Power Exchange. Eligibility Entity can exchange the ESCerts either directly on a Power Exchange or through a Member of a Power Exchange.

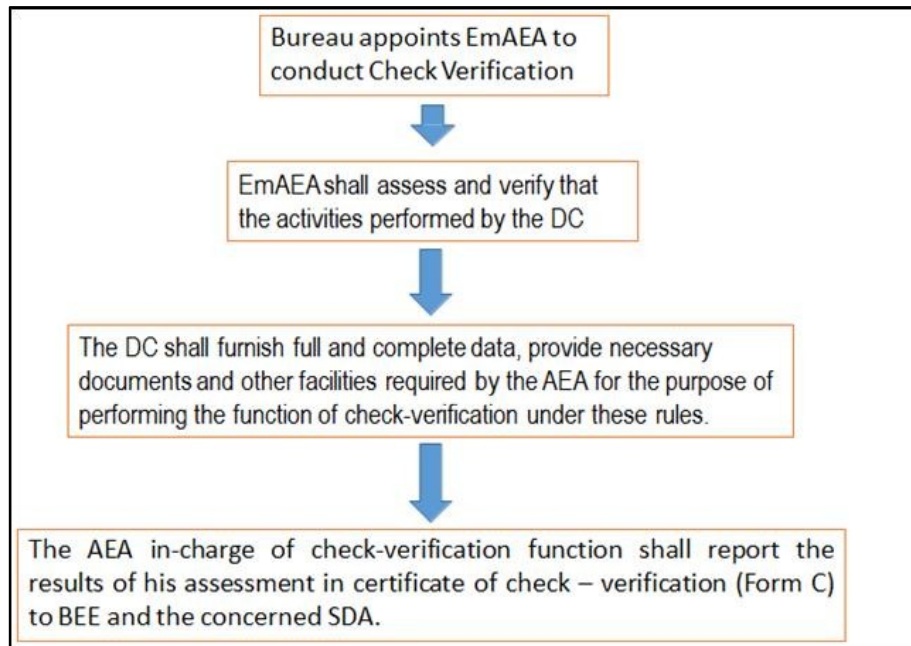
#### **The various stakeholders' roles in dealing of ESCerts are summarised as follows:**

- Issuance of ESCerts – Ministry of Power
- Registration of DCs – Registry (NLDC, POSOCO)
- Trading of ESCerts – Power Exchanges
- Facilitation of trading of ESCerts – Registry
- Updation of accounts of DCs – Registry
- DC submit ESCerts for compliance – Bureau of Energy Efficiency
- Extinguishment of ESCerts- Registry
- Database of ESCerts / Banked ESCerts – Registry

## **2.8 Check Verification**

The BEE may on its own or on receipt of a complaint within one year from the date of submission of compliance report (Form D) shall initiate check-verification of any DC.

The process of check verification is illustrated in Figure 2.7.



**Figure 2.7: Process of Check Verification**

Obligations of the Empanelled Accredited Energy Auditor:

1. For verification or check verification, the accredited energy auditor shall constitute a team comprising a team leader and other members including Process Experts:
  - Provided that a person, who was in the employment of a designated consumer within the previous four years, shall not be eligible to perform the work of verification or check-verification for such a designated consumer;
  - Provided that any person or firm or company or other legal entity, who was involved in undertaking energy audit in any of the designated consumer within the previous four years, shall not be eligible to perform the work of verification or check-verification for such a designated consumer
2. The accredited energy auditor shall ensure that persons selected as team leader and team members must be independent, impartial and free of potential conflict of interest in relation to activities likely to be assigned to them for verification or check-verification.
3. The accredited energy auditor shall have formal contractual conditions to ensure that each team member of verification and check-verification teams and technical experts act in an impartial and independent manner and free of potential conflict of interest.
4. The accredited energy auditor shall ensure that the team leader, team members and experts prior to accepting the assignment inform him/her about any known, existing, former or envisaged link to the activities likely to be undertaken by them regarding verification and check verification.

5. The accredited energy auditor must have documented system for determining the technical or financial competence needed to carry out the functions of verification and check-verification and in determining the capability of the persons, the accredited energy auditor shall consider and record among other things the following:
  - a) complexity of the activities likely to be undertaken;
  - b) risks associated with each project activity;
  - c) technological and regulatory aspects;
  - d) size and location of the designated consumer;
  - e) type and amount of field work necessary for the verification or check-verification.
6. The accredited energy auditor shall have a documented system for preparing the plan for verification or check-verification functions and that plan shall contain all the tasks required to be carried out for each type of activity, in terms of man days in respect of designated consumers for the purpose of verification and check-verification.
7. The accredited energy auditor shall provide in advance the names of the verification or check-verification team members and their biodata to the designated consumer concerned.
8. The accredited energy auditor shall provide the verification or check-verification team with the relevant working documents indicating their full responsibilities with intimation to the designated consumer.
9. The accredited energy auditor shall have documented procedures for the following:
  - a) to integrate all aspects of verification or check-verification functions;
  - b) for dealing with the situations in which an activity undertaken for the purpose of compliance with the energy consumption norms and standards or issue of energy savings certificate shall not be acceptable as an activity for the said purposes.
10. The accredited energy auditor shall conduct independent review of the opinion of verification or check-verification team and shall form an independent opinion and give necessary directions to the said team if required.
11. In preparing the verification and check-verification reports, the accredited energy auditor shall ensure transparency, independence and safeguard against conflict of interest.
12. The accredited energy auditor shall ensure the confidentiality of all information and data obtained or created during the verification or check verification report.

13. In assessing compliance with energy consumption norms and standards and issue of energy saving certificates, the accredited energy auditor shall follow the provisions of the Act, rules and regulations made thereunder.
14. After completion of the verification or check-verification, the accredited energy auditor shall submit the verification (in Form-“B”) or check-verification report, together with the certificate in Form-‘C’, to the Bureau.

## **2.9 Enforcement of Compliance to PAT**

Enforcement under PAT is spelled in under the Section 26 (1A). The guiding clause states: “If any person fails to comply with the provisions of the clause (n) of section 14, he shall be liable to a penalty which shall not exceed ten lakh rupees and, in the case of continuing failure, with an additional penalty which shall not be less than the price of every metric ton of oil equivalent of energy, prescribed under this Act, that is I excess of the prescribed norms.” The development of adjudication framework is under progress.

## **2.10 PAT Development**

### ***PAT-1 Achievement***

PAT Cycle-I (2012–15) was envisaged to reduce the SEC of 478 designated consumers (DCs) from eight energy intensive sectors viz. Aluminium, Cement, Chlor Alkali, Fertilizer, Iron & Steel, Paper & Pulp, Thermal Power Plant and Textile. The baseline period was considered as average of three years namely 2007–08, 2008–09, 2009–10. The Assessment year was 2014–15 and M&V period was from April–June, 2015.

The first cycle of PAT was completed in March 2015. Subsequently, verification of the performance of DCs with regard to energy savings took place and based on recommendations made by BEE, the Ministry of Power issued 38.24 lakhs ESCerts to 309 DCs in Feb 2017. DCs (110 nos) have been entitled to purchase 14.23 lakhs ESCerts to meet the shortfall to meet energy saving targets.

PAT-I cycle has achieved an energy saving of 8.67 million tonne of oil equivalent (MTOE) against the targeted energy saving of 6.886 MTOE which is about 30% more than the target.

All the sectors except thermal power plant surpassed the targets. The energy saving is equivalent to 31 million tonnes of CO<sub>2</sub> emission reduction and monetary savings of INR 95.09 billion which encouraged investment of INR 261 billion for energy efficient technologies were the highlights. The foundation for PAT-1 was laid with capacity building of 13718 certified energy Auditors and Managers which include 219 accredited energy



auditors and 53 Empanelled Accredited Energy Auditors The Table 2.2 summarizes the achievements of PAT-I.

**Table 2.2: PAT Cycle-I (2012-13 to 2014-15)**

<b>S. No.</b>	<b>Sectors</b>	<b>No. of DCs</b>	<b>Target Reduction (MTOE)</b>	<b>Savings (MTOE)</b>	<b>% Increase</b>
1	Aluminium	10	0.46	0.73	59%
2	Cement	75	0.82	1.44	76
3	Chlor- Alkali	22	0.05	0.13	100
4	Fertilizer	29	0.48	0.83	73
5	Iron & Steel	60	1.49	2.10	41
6	Paper & Pulp	26	0.12	0.26	117
7	Textile	82	0.07	0.12	71
8	Thermal Power Plant	123	3.21	3.06	-5%
<b>Total</b>		<b>427</b>	<b>6.69</b>	<b>8.67</b>	<b>29%</b>

### ***PAT Cycle II Update***

After completion of PAT Cycle –I, PAT Scheme was expanded by carrying out Widening and Deepening study.

### **Widening of PAT**

PAT scheme was widened by including three new sectors i.e. Railways, Refinery and DISCOMs. A total of 84 DCs were notified in PAT cycle –II as a result of widening of the scheme. .

### **Deepening of PAT**

Deepening of PAT scheme was carried out by identifying new DCs from existing sectors of PAT scheme. As a result of deepening of PAT, 89 DCs were notified under PAT cycle –II.

PAT Cycle –II has been notified in March 2016 in which 621 DCs from 11 sectors have been notified with a target reduction of 8.869 MTOE. . The breakup of 621 DCs notified in PAT cycle –II is as follows:

1. Existing DCs of PAT Cycle –I : 448
2. New DCs from existing 8 sectors of PAT: 89
3. DCs from new sectors i.e. Railway, Refinery and DISCOM: 84

The details of DCs in each sector with widening and deepening of PAT are shown in the Table 2.3.

**Table 2.3: Details of DCs in PAT-II (2016-2019)**

S. No	Sector	No. of DCs in PAT I	Additional DC in PAT Cycle-II	Total no. of DCs PAT -2
1	Aluminium	10	2	12
2	Chlor-Alkali	22	3	24
3	Textile	90	14	99
4	Pulp & Paper	31	4	29
5	Iron & Steel	67	9	71
6	Fertilizer	29	8	37
7	Cement	85	27	111
8	Thermal Power Plants	144	22	154
9	Refinery	NA	18	18
10	DISCOMS	NA	44	44
11	Railway	NA	22	22
<b>Total</b>				621

### **Railways**

All zonal railways with annual energy consumption for traction of 70,000 TOE per year and above and Workshop/Production units with annual energy consumption of 30,000 TOE or above are included as DCs. The specific energy/fuel consumption norms of electric & diesel traction have been considered for setting up the target for reduction as shown in Table 2.4.

Zonal Railways: Each zonal railway provides transport services for both passenger and goods. The energy input for the mentioned services is in the form of diesel or electricity. Specific fuel consumption or specific energy consumption for a specific service (passenger or goods), is calculated by dividing the total amount of fuel input in liters or kWh by the total gross tonne kilometrage for the respective service.

<b>Table 2.4: SEC Norms for Electric /Diesel Traction of Zonal Railways</b>			
<b>Diesel</b>		<b>Electrical</b>	
<b>Passenger</b>	<b>Goods</b>	<b>Passenger</b>	<b>Goods</b>
<b>Litres/1000GTkm</b>	<b>Litres/1000GTkm</b>	<b>kWh/1000GTkm</b>	<b>kWh/1000GTkm</b>

GTkm- Gross Tonne kilometres

Production Units/Workshops: Production units of Indian Railways manufacture a variety of products like locomotives, coaches, wheels axles etc. If more than one variety of product is

manufactured under the same category (say AC coach and non AC coach), equalized number of units will be considered to calculate SEC.

For **Production Units**, metric considered is energy consumption per unit of production (locomotives, coaches, wheels etc.). All the energy consumption will be converted into toe and metric will be **KgOE /unit of production**.

### **Electricity Distribution Companies (DISCOMs)**

Energy losses occur in the process of supplying electricity to consumers due to technical and commercial reasons. Technical losses are due to energy dissipated in the conductors, transformers and other equipment used for transmission, transformation, sub-transmission and distribution of power. Although, inherent in the system, technical losses can be reduced to a certain level.

Pilferage of electricity by hooking, bypassing meters, defective meters, errors in meter reading and in estimating un-metered supply of electricity are included as Commercial losses. When Commercial losses are added to Technical losses, it is called Transmission & Distribution (T&D) losses

T&D losses across India average about 25% and they can reach up to 50% in some areas This means that half of electricity being generated either never reaches an end-user or is used but never paid for.

There is another component of Commercial losses, which is attributable to non-recovery of the billed amount, which is reflected in collection efficiency. This loss represents shortage due to non-realization of billed amount.

T&D losses together with loss in collection are called Aggregate Technical & Commercial (AT&C) losses.

**T&D loss is the parameter chosen for reduction; DISCOMs with annual AT&C losses of 1000 MU/86000 TOE and above are included as DCs.**

### **Refinery**

Petroleum refinery is a vital industry which assumes significant strategic importance in Indian economy. India is one of the largest consumer of oil and petroleum products in the world. To meet the growing demand of petroleum products, the refining capacity in the country has gradually increased over the years by setting up of new refineries in the country as well as by expanding the refining capacity of the existing refineries. There are a total of 23 refineries in the country comprising 18 in the Public Sector, 3 in the Private Sector and 2 as joint ventures. The total refinery capacity as on 1st April 2015 was 215.066 MMTPA.

Petroleum Refinery sector is one of the important energy intensive sector covered in PAT cycle-II. In order to induce the energy conservation in the refinery sector, refineries having energy consumption of 90,000 Metric Tonne of Oil Equivalent (MTOE) and above are notified as Designated Consumers and included in PAT Cycle-II. Total 18 refinery units are notified as Designated Consumers under PAT cycle-II with an overall sectoral energy reduction target of 5.97%. The target for Petroleum Refinery sector is 1.10 Million Metric Tonne of Oil Equivalent.

In Petroleum Refinery sector, the process includes up gradation of undesirable components of the crude oil into more valuable products, such as gasoline, diesel, and jet fuel and other low value by-products, such as fuel oils and lubricants. Specific energy consumption is not an appropriate indicator of the energy performance of the refineries as it does not account for differences in complexities, output slates, or type of crude processed. Thus, the energy performance of refineries is expressed in terms of specific energy consumption, measured in thousand British Thermal Units (BTU) per barrel per Energy Factor (MTBU/BBL/NRGF). This unit, commonly referred to as MBN, was developed by the Centre for High Technology, Ministry of Petroleum & Natural Gas to provide a basis for comparing energy performance of refineries of different configurations and accounting of the throughput of secondary units. The NRG factor (NRGF) is the indicator of the level of complexity of a refinery.

$$MBN = \frac{\frac{\text{Thousand British Thermal Units}}{\text{Barrel}}}{NRGF}$$

$$\text{Overall NRGF of units} = \frac{\sum_{k=1}^n (\text{Throughput of unit in KL} \times \text{Energy factor of unit})}{\text{Crude Throughput of refineries in KL}}$$

### **PAT Cycle III**

#### **Rolling Cycle**

From PAT III (1<sup>st</sup> April, 2017 onwards), PAT scheme is being implemented on a rolling cycle basis and new DCs/sectors are being included every year.

PAT III seeks to achieve overall energy consumption reduction of 1.06 MTOE for which SEC reduction targets have been assigned to 116 Designated Consumers from six sectors viz. Thermal Power Plant, Cement, Aluminium, Pulp & Paper, Iron & Steel and Textile. The energy consumption of these DCs is 34.17 MTOE (Table 2.5).

**Table 2.5: Targets for PAT-III (2017-2020)**

<b>S. No</b>	<b>Sector</b>	<b>No of DCs</b>	<b>Energy Consumption (MTOE)</b>	<b>Energy Savings Target (MTOE)</b>
1	Thermal Power Plant	37	23.82	0.402
2	Cement	14	1.74	0.096
3	Aluminium	1	1.02	0.061
4	Pulp & Paper	1	0.06	0.003
5	Iron & Steel	29	6.860	0.409
6	Textile	34	0.668	0.040
<b>Total</b>		<b>116</b>	<b>34.17</b>	<b>1.06</b>

**PAT Cycle IV**

The Notification for PAT cycle -IV was issued in March, 2018 and commenced from 1<sup>st</sup> April, 2018 onwards and it included two new sectors namely commercial buildings (Hotels–37 nos), Petrochemical sector (8 nos) in addition to new DCs in existing sectors. The duration of PAT cycle–IV will be from 2018-19 to 2020-21. With PAT IV, number of DCs covered under all PAT cycles has increased to 846 with additional 109 as shown in Table 2.6.

**Table 2.6: No. of DCs Covered in PAT Cycles II, III, and IV**

<b>Sector</b>	<b>DCs in PAT Cycle II (2016-19)</b>	<b>DCs in PAT Cycle III (2017-20)</b>	<b>DCs in PAT Cycle IV (2018-21)</b>	<b>Total DCs</b>
Aluminium	12	1	-	13
Cement	111	14	1	126
Chlor-alkali	24	-	2	26
Fertiliser	37	-	-	37
Iron and Steel	71	29	35	135
Pulp and paper	29	1	2	32
Textile	99	34	7	140
Thermal power	154	37	17	208
Zonal railways	22	-	-	22
Refineries	18	-	-	18
Discoms	44	-	-	44
Commercial buildings (hotels)	1	-	37	37
Petrochemicals	1	-	8	8
<b>Total</b>	<b>621</b>	<b>116</b>	<b>109</b>	<b>846</b>

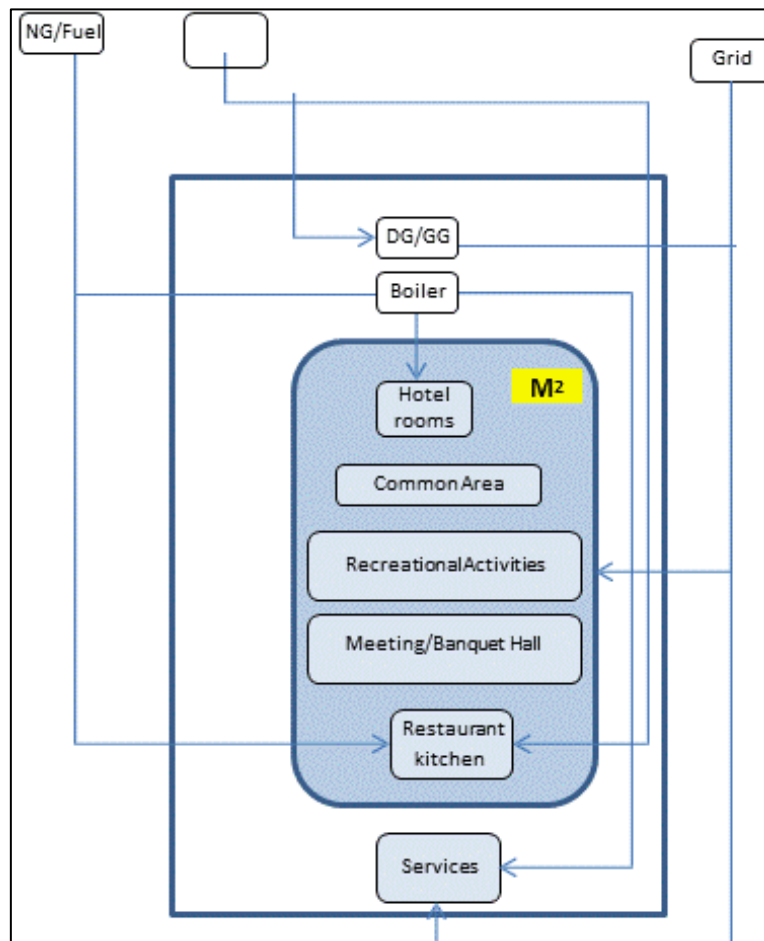
Source: BEE

For **petrochemical sector**, the metric proposed is  
**toe/ton of product.**

For commercial building, buildings used around the clock (24 hours) are being considered. The PAT cycle IV is from 2018-19 to 2020-21. GtG for building excludes basement parking area (Figure 2.8). The metric proposed for commercial building is as follows:

For **commercial building**, the metric proposed is  
**Net Input Energy in toe**  
**Net Built-up area excluding basement parking area in ('000 m<sup>2</sup>)**

Input Net Energy: Fuel and Power in tonnes of oil equivalent



**Figure 2.8: GtG for Building**

### 3. KEY THRUST AREAS OF ENERGY CONSERVATION ACT, 2001

#### 3.1 Introduction

The various provisions of Energy Conservation Act, 2001 are discussed in detail in BEE guide books. It may be noted that Perform, Achieve and Trade (PAT) is covered in Chapter-2. The coverage in this chapter is limited to other key areas of The Energy Conservation Act, 2001 namely Standard & Labelling, Star Rating for Buildings, and the Energy Conservation Building Code (ECBC).

#### 3.2 Standard & Labelling

There is a wide variation in energy consumption of the same products by different manufacturers. Information on energy consumption is often not easily available nor sufficient or easy to understand from the nameplate affixed on product leading to continued manufacture and purchase of inefficient appliances and equipment. For example, a consumer may be aware of choosing 18 W compact fluorescent light bulbs over 60 W incandescent bulbs. But wattage is no substitute for the information that an energy label can provide namely lumen output and product life. Such information is not readily available to consumers unless it is included on a product label.

Consumer's purchase decisions are largely driven by the **cost of owning** the appliance (paid at the time of purchase) and they tend to overlook the **cost of using** the appliance (paid over its lifetime through the electricity bill). Once consumers are informed about the future benefits, they are more likely to take more rational decision.

In order to provide consumer with this information, Bureau of Energy Efficiency introduced the Standards and Labelling (S&L) Program in 2006 to provide the consumer an informed choice about the energy saving and thereby cost saving potential of the marketed product.

Energy 'labelling' is one of the most cost effective policy tools for improving energy efficiency and lowering energy cost of appliances/equipment for the consumers. The energy efficiency labelling programs under BEE are intended to reduce the energy consumption of appliance without affecting the services it provides to consumers.

Implementation of S&L is expected to produce large energy savings, limiting energy growth of the country without affecting economic growth—reduced Investment in energy supply infrastructure. Such energy savings are generally assured and verified. Low energy-efficiency products are excluded from the market and consumers are benefitted in terms of cost savings as well as getting better quality products.

### 3.2.1 Standard

Energy-efficiency standards are procedures and regulations that prescribe limits on the energy consumption (or minimum levels of the energy efficiency) of manufactured products. Intention is to prohibit the sale of products that are less energy efficient than the minimum prescribed standards, called as Minimum Energy Performance Standards (MEPS). Well-defined test protocols ensures sufficiently accurate estimate of MEPS.

By setting minimum energy performance levels or minimum required levels of quality, benefits are as follows:

- Increased average efficiency or quality of products on the market
- Reduced energy costs
- Reduced greenhouse gas emissions
- Protected consumers
- Improved market efficacy & competition

### 3.2.2 Label

Energy-efficiency labels are information affixed to manufactured products and usually communicate the product energy performance (usually in terms of efficiency as compared to similar products, energy cost to run the appliance, emissions etc.). Labels inform smart choices on the best products to consumers. They also make it easier for utility companies, government energy agencies, and others to procure in bulk or offer consumers incentives to buy energy-efficient and high quality products. To help the best products stand out, labels:

- Recognize best products
- Describe product performance & quality
- Promote competition & innovation

The labels provide visually information about EE standards to the consumers. EE labels can either give detailed information about a product's energy performance, or simply indicate that a product has met certain energy performance.

#### **Endorsement Labels**

The purpose of endorsement labelling is to indicate clearly to the consumer that the labelled product saves energy compared to other similar products in the market. They are essentially *seals of approval* given according to specified criteria (Figure 3.1).

This helps customer to make wise decision to choose most efficient products. Such labels also encourage industries to develop and produce high efficiency and quality products. The products having endorsement label will have stronger



**Figure 3.1: Endorsement Label (Laptops)**

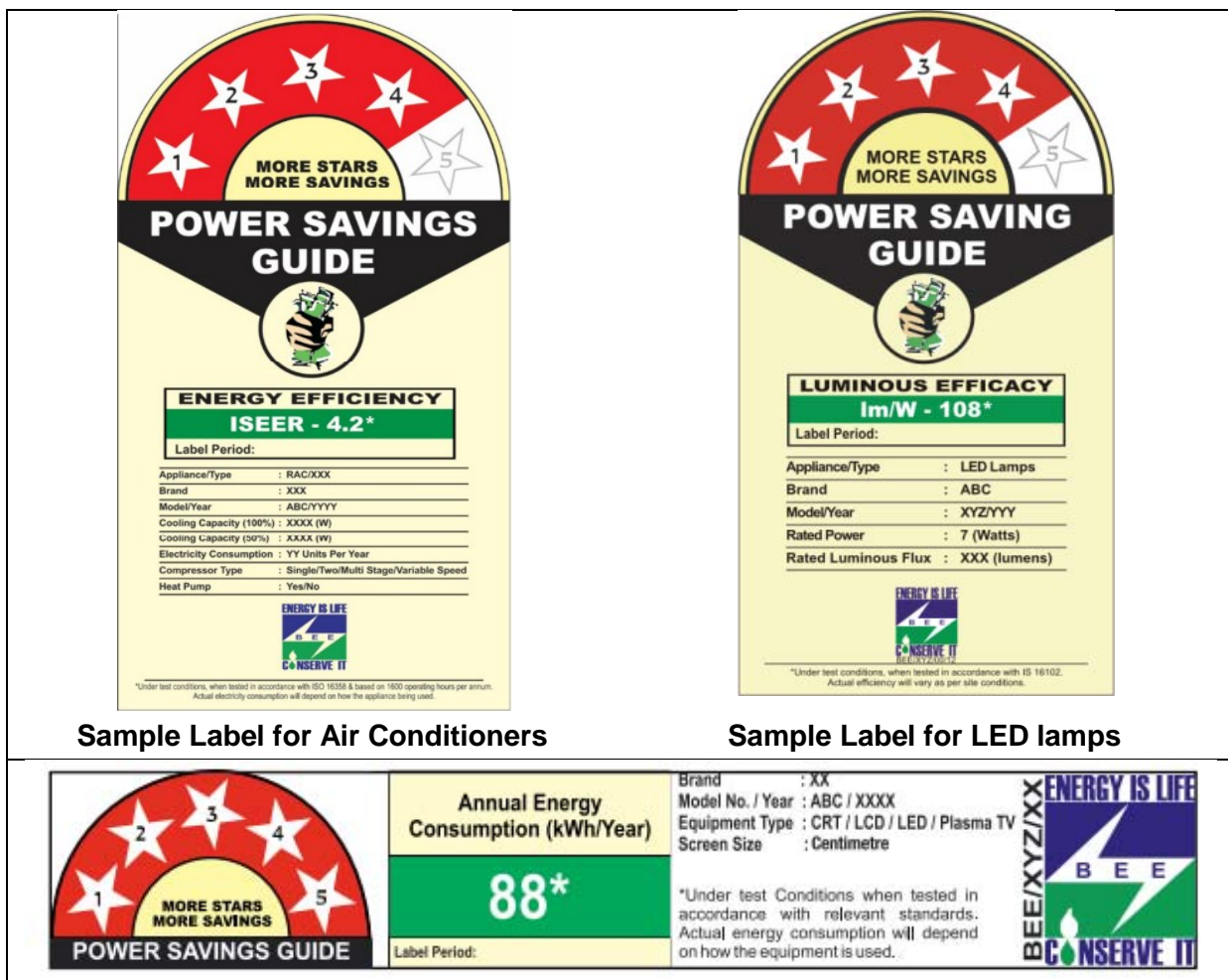


competiveness in the market. Endorsement labelling programs are inherently voluntary since they do not seek to eliminate the least efficient products from the market.

**Comparative Labels**

Comparative labels allow consumers to compare performance among similar products using either discrete categories of performance or a continuous scale. The use of comparative labels can motivate manufacturers to build products that are more efficient or of a higher quality than those already on the market. Examples of comparative labels for air conditioners, LED lamps, and colour television are shown in Figure 3.2.

Endorsement Labels	Comparative Labels
Provide 'certification' to inform prospective purchasers that the product is highly energy efficient for its category.	Allow consumers to compare the energy consumption of similar products, and factor lifetime running cost into their purchasing decision.
Endorsement labels can be standalone or integrated and shown on comparative labels.	Show relative energy use of a product compared to other models available in the market.



**Sample Label for Colour Television**  
**Figure 3.2: Examples of Comparative Labels**

Taken together, standards and labels shift global markets to the highest quality, and lowest impact appliances. Standards drive inappropriate products from the market, protect consumers and provides level playing field for manufacturers, distributors, and procurers. Labels draw consumers and other buyers to the best and most innovative products.

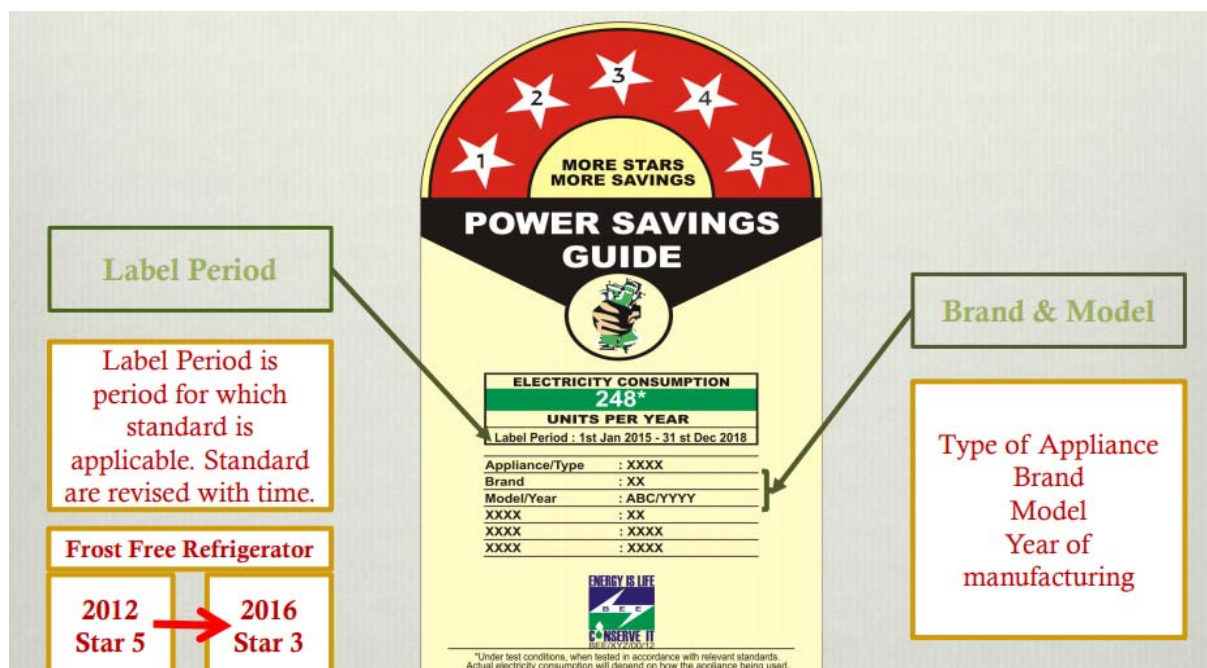
The energy efficiency labelling programs under BEE are intended to reduce the energy consumption of appliance without affecting the services it provides to consumers. The BEE S&L scheme is invoked for 21 equipment/appliances including 10 for which it is mandatory. The other appliances are presently under voluntary labelling phase. The star labelling program for 22<sup>nd</sup> appliance i.e. Chillers has been launched on voluntary basis recently in the month of September, 2018.

### **Products notified under mandatory labelling**

As of September 2018, the following products have been notified under mandatory labelling:

1. Frost Free (no-Frost) Refrigerators	6. Direct Cool Refrigerators
2. Tubular Fluorescent Lamps	7. Electric Geysers
3. Room Air Conditioners	8. Color TV
4. Distribution Transformers	9. Room Air Conditioners (Inverter type)
5. Room Air Conditioners (Cassette, Floor Standing Tower, Ceiling, Corner AC)	10. LED lamps

For example, label information for a *refrigerator* contains the following information (Figure 3.3):



**Figure 3.3: Label Information for a Refrigerator**

### **Products under voluntary labelling**

As on September 2018, the following products have been notified under voluntary labelling:

1. Induction Motors	7. Ballast (Electronic/Magnetic)
2. Agricultural pump sets	8. Office equipment's (Printer, Copier, Scanner)
3. Ceiling fans	9. Diesel Engine Driven Monoset Pumps for Agricultural Purposes
4. Domestic Liquefied Petroleum Gas (LPG) Stoves	10. Solid State Inventor
5. Washing machine (Presently BEE is in process of revising the program)	11. Diesel Generator
6. Computer (Notebook/Laptops)	12. Chillers

### **Future – Equipment/appliances proposed for Standards & Labelling**

1. Microwave Ovens	6. DC based Lighting
2. Set top boxes	7. DC based Fans
3. Solar Photo Voltaic	8. DC based Television
4. Solar Water Heater	9. Mobile Phone Chargers
5. Solar Pumps	

### **3.2.3 Energy Saving Calculation for Submersible Pump Set**

**Example:**

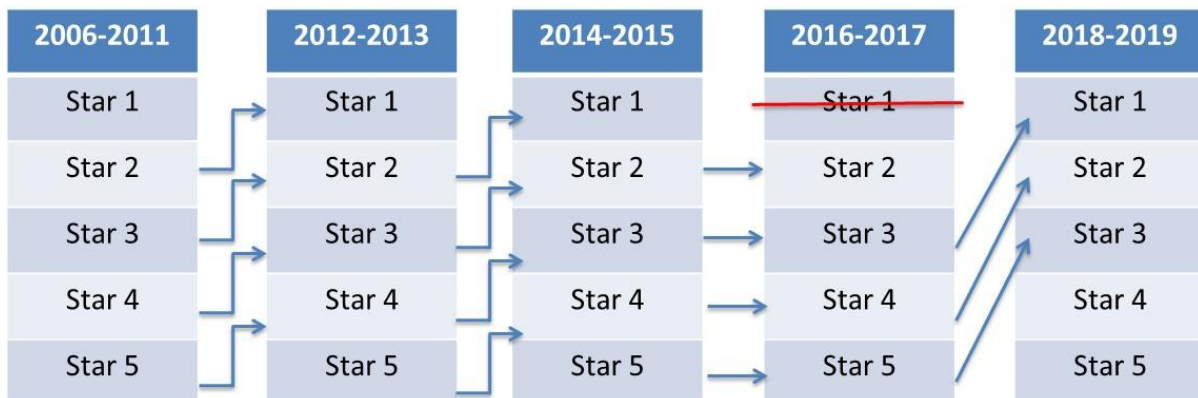
Head	73 m
Discharge	6.67 lps, Stage= 7, Rating = 7.5 kW
BIS efficiency (i.e. 1 star efficiency)	43.66%
Power consumption (Baseline)	$(73 \times 6.67 \times 9.81) / (1000 \times (43.66/100)) = 11 \text{ kW}$
5 Star efficiency	$1.2 \times 43.66 = 52.39\%$ (Performance factor for 5 star rating = 1.2)
Power consumed by 5 star energy efficient pump	$(73 \times 6.67 \times 9.81) / (1000 \times (52.39/100)) = 9 \text{ kW}$
Energy Saving	$(11-9) \times 4 \times 200 = 1600 \text{ kWh/year}$
Cost Saving (INR 5/unit)	$1600 \times 5 = \text{INR } 8000/\text{year}$

Head (meter)	Discharge (lps)	Rating (kW)	Power Consumption for 1 Star (kW)	Power Consumption for 5 Star (kW)	Energy Saving (kWh/year)
73	6.67	7.5	11	9	1600
122	6.6	13	17.5	14.5	2400
98	3.6	5.6	8.7	7.3	1120

Informed customers are likely to be motivated to buy products with 2–3 years payback periods. Labeling seldom works if payback period for the product is more than 4–5 years

### 3.2.4 Star-label Upgradation

Star labelling program gets updated every year as the technology improves and more and more efficient products are made available, the labels will accordingly adjust (Figure 3.4). For example, an appliance manufactured in 2018 and rated five star will more efficient than a five star rated similar appliance in 2017.



**Figure 3.4: Example of Star level Upgradation under Star Labelling program of Variable Speed Room Air Conditioners**

### 3.3 Star Rating of Building

Energy audit studies in buildings have shown large potential for energy savings both in government and commercial office buildings. The Bureau of Energy Efficiency has developed a scheme for energy efficiency labeling of Buildings, in February 2009. The star rating of building is aimed at accelerating energy efficiency activities in commercial buildings across the country. The Star rating Programme would provide public recognition to energy efficient buildings, thus creating a market demand for such buildings. This programme would rate buildings on a 1-5 Star scale with 5 Star labelled buildings being the most efficient.

BEE Star Rating Scheme is based on **actual performance of the building** in terms of **specific energy usage** termed as **Energy Performance Indicator (EPI)**.

- Ratings apply to buildings with a connected load of 100 kW or a contract demand of 120 KVA, whichever is greater and are intended to be used for commercial purposes.
- The programme covers five categories of commercial buildings—office buildings, hotels, hospitals, retail malls, and IT parks—in four climate zones across the country.
- Buildings in climatic zones namely Warm and Humid, Composite, Hot and Dry, Temperate regions are being currently rated.
- Criteria indicating EPI value and corresponding Star Label under the various climatic zones (for buildings having air conditioned area greater than 50% of their built up area & for buildings having air conditioned area less than 50% of their built up area) are referred for assigning Star Label.

Office Building	BPO
<ul style="list-style-type: none"> <li>• EPI shall be <b>kWh/sq.m/year</b> in terms of <b>Purchased &amp; Generated Electricity</b> divided by <b>Built up Area in sq.m.</b></li> <li>• The total electricity should not include electricity generated from on-site renewable sources such as solar photovoltaic etc.</li> </ul>	<ul style="list-style-type: none"> <li>• EPI shall be <b>Average Annual hourly Energy Performance Index (AAhEPI) in (Wh/hr/sq.m)</b>, which is <b>Purchased &amp; Generated Electricity</b> divided by <b>Built up Area in sq.m and Total Annual Hours of Operation.</b></li> <li>• The total electricity should not include electricity generated from on-site renewable sources such as solar photovoltaic etc.</li> </ul>

### Case study

A BPO building owner had applied for 5 star rating for its building having air conditioned area greater than 50% located in warm & humid region. The verified Building Information and Energy Data and Actual Average Annual hourly EPI (AAhEPI) in (Wh/hr/sq.m) was 34.18 (Table 3.1). The calculated value falls within bandwidth 36–30 under Warm & Humid category (Table 3.2) and the corresponding rating is 4 star. Therefore, The BPO building is eligible for only 4 star rating.

**Table 3.1: Verified Building Information and Energy Data for the BPO**

Name of the Building: XXX

City: Chennai

**Building Information and Energy Data**

Primary Data		Year: 2018	
No	Item	Value	
1	Connected Load (kW) or Contract Demand (kVA)	16000 KVA	
2	Installed capacity: DG/ GG Sets (kVA or kW)	27200 kVA	
3	a) Annual Electricity Consumption, purchased from Utilities (kWh)	57981450	
	b) Annual Electricity Consumption, through Diesel Generating (DG)/Gas Generating (GG) Set(s) ( kWh)	913482	
	c) Annual Solar Consumption (Kwh)	1445224	
	d) Total Annual Electricity Consumption, Utilities + DG/GG Sets (kWh)*	<b>58894932</b>	
4	a) Annual Cost of Electricity, purchased from Utilities (Rs.)	438775023	
	b) Annual Cost of Electricity generated through DG/GG Sets (Rs.)	12951964	
	c) Total Annual Electricity Cost, Utilities + DG/GG Sets (Rs.)	451726987	
5	Area of the building (exclude parking, lawn, roads, etc.)	a) Built Up Area (sqm)(excluding Basement Area)	<b>196646.29</b>
		o Conditioned Area(in s.qm.)	16980029
		o Conditioned Area(as % of built up area)	86%
6	Working hours (e.g. day working /24 hour working)	24 hrs	
7	Working days/week (e.g. 5/6/7 days per week)	7 days	
8	a) Office	Total no. of Employees	19827
		Average .no. of Persons at any time in office during office hours	16800
9	a) Installed capacity of Air Conditioning System (TR)	7550	
10	Installed lighting load (kW) ( if available)	710	
12	HSD (or any other fuel oil used, specify)/Gas Consumption in DG/GG Sets (liters/cu. meters) in the year	277761 Lts.	
13	Fuel (e.g. FO, LDO,LPG, NG) used for generating steam/water heating in the year (in appropriate units)	Nil	
14	Average Annual hourly EPI (AAhEPI) in (Wh/hr/sqm) Energy includes electricity purchased and generated ( excluding electricity generated from on-site renewable resources)	<b>34.18</b>	
15.	Climate Zone	<b>Warm &amp; Humid</b>	
16	<b>Star Label applicable</b>	<b>4</b>	

- Excludes annual solar solar power consumption

I hereby declare that the building is fully occupied for the last one year and all the above furnished information is true in all respect

-SD-

Signature of the BPO building owner or  
Authorized representative

**Table 3.2: Bandwidths for BPO Buildings for 4 Climatic Zones\***

**Average Annual hourly EPI (AAhEPI)**

For buildings having air conditioned area greater than 50%

Climatic Zone	Average Annual hourly EPI AAhEPI (Wh/hr/sq.m)	Star Rating
COMPOSITE	52 – 46	1 Star
	46 – 40	2 Star
	40 – 34	3 Star
	34 – 28	4 Star
	Below 28	5 Star

Climatic Zone	Average Annual hourly EPI AAhEPI (Wh/hr/sq.m)	Star Rating
WARM & HUMID	54 – 48	1 Star
	48 – 42	2 Star
	42 – 36	3 Star
	<b>36 – 30</b>	<b>4 Star</b>
	Below 30	5 Star

Climatic Zone	Average Annual hourly EPI AAhEPI (Wh/hr/sq.m)	Star Rating
HOT & DRY	37 – 31	1 Star
	31 – 25	2 Star
	25 – 19	3 Star
	19 – 13	4 Star
	Below 13	5 Star

Climatic Zone	Average Annual hourly EPI AAhEPI (Wh/hr/sq.m)	Star Rating
TEMPERATE	47 – 41	1 Star
	41 – 35	2 Star
	35 – 29	3 Star
	29 – 23	4 Star
	Below 23	5 Star

\* Due to insufficient number of BPO buildings located in the cold climatic zone, the above table does not include the cold region.

### 3.4 Energy Conservation Building Code (ECBC) for Non-Residential (Commercial) Buildings

The building sector in India consumes over 30% of the total electricity consumed in the country annually and is second only to the industrial sector as the largest emitter of greenhouse gases. Building energy codes for new buildings are an important regulatory measure for ushering energy efficiency in the building sector. They are particularly relevant for countries like India where the building constructions are rising rapidly.

Considering the energy intensive nature of buildings, Ministry of Power, Bureau of Energy Efficiency launched the '**Energy Conservation Building Code (ECBC)**' code in 2007. The purpose of the Energy Conservation Building Code (ECBC) is to encourage energy efficient design or retrofit of buildings so without affecting the building function, comfort, health, or the productivity of the occupants with appropriate regard for economic considerations. ECBC also addresses local design conditions and helps improve existing construction practices. The emphasis of BEE is on *Integrated Building Design* approach. ECBC is also easy to use and encourages continuous improvisations. The code was revised and updated in 2017 to match with the technology developments to set higher benchmarks for energy efficiency.

ECBC has the potential to transform the way buildings are being constructed. Although ECBC is applicable for buildings all over India, States have the authority to adapt and mandate ECBC according to local requirements. ECBC is being adapted with minor additions in different States and ECBC compliance is now mandatory. ECBC is also being incorporated into local bye-laws and added to Urban Local Bodies (ULBs) building approval process.

#### 3.4.1 Impact of ECBC Compliance

Few of the benefits of ECBC are:

- Lower HVAC loads – reduced energy consumption and operational cost
- Lesser addition of power generation capacity– better building performance
- Climate oriented design practice
  - Improved lighting and extensive use of day lighting
  - Use of natural ventilation/free-cooling systems
- Market demand for energy efficient products like glass, insulation, HVAC equipment etc.

#### 3.4.2 Scope of ECBC (Commercial Buildings)

This code is now mandatory and applicable to buildings or building complexes that have a connected load of 100 KW or a contract demand of 120 KVA, whichever is greater and are intended to be used for commercial purposes.

ECBC also applies to addition and major renovation:



- Where the new connected load demand of the addition plus the existing building exceeds 100 kW or 120 kVA.
- When addition + existing building area > 1000 m<sup>2</sup>
- Renovated portions and systems of a 1000 m<sup>2</sup> or larger building

The additions shall comply with the provisions of section 4 through 7 as per ECBC guideline. Compliance may be demonstrated in either of the following ways:

1. The addition shall comply with the applicable requirements, or
2. The addition, together with the entire existing building, shall comply with the requirements of this Code that shall apply to the entire building, as if it were a new building.

### 3.4.3 Applicable Building Systems

This code addresses the minimum performance requirements in a commercial building covering the following:

a) Building envelope	refers to exterior façade, and is comprised of walls, windows, roof, skylights, doors and other openings, The design features of the envelope affects the visual and thermal comfort of the occupants, as well as energy consumption of the building.
b) Mechanical systems and equipment, including heating, ventilating, and air conditioning, service hot water heating	Refers to Heating, Ventilation (natural, mechanical), Air Conditioning (cooling, dehumidification, humidification)
c) Interior and exterior lighting	Refers to Day Lighting, Glazing, Energy Efficient Lighting, Lighting Controls, Interior/Exterior lighting power
d) Electrical power and motors, and Renewable energy systems	Refer to Efficient Transformers, High Efficiency Motors, Power Factor controls, Power Distribution Losses (minimum) Service Hot Water and Pumping

The provisions of this code do not apply to plug loads, and equipment and parts of buildings that use energy for manufacturing processes, unless otherwise specified in the Code.

### 3.4.4 Building Classification

The following are the classifications of building as per ECBC:

- Hospitality: Star/non Star Hotels, Resorts
- Healthcare
- Assembly: Religious, Recreation, Social, Picture hall, Bus/Rail/Airports
- Business: Large >30000 sq.m, Medium:<30000-10000 Sq.m, small<10000 Sq.m
- Educational

- Shopping Complexes
- Mixed Building

### 3.4.5 Levels of Energy Efficiency Performance

The ECBC 2017 has incorporated advanced technologies and additional parameters related to renewable energy integration, inclusion of passive design strategies, flexibility for the designers and ease of compliance. The revised ECBC is one of the first building energy codes to recognize beyond code performance. The code prescribes the following three levels of energy efficiency: ECBC Buildings, ECBC+ Building, and SuperECBC Building.

The adherence to the minimum requirements stipulated for ECBC level of efficiency would demonstrate compliance with the code. Other two efficiency levels namely ECBC+ and SuperECBC are of voluntary nature. This feature was added to prepare the building industry for meeting energy efficiency standards in coming years and give sufficient time to the market to adapt.

**ECBC Buildings** shall demonstrate compliance by adopting the mandatory and prescriptive requirements listed under ECBC Compliant Building requirements, or by following the provisions of the Whole Building Performance (WBP) Method. An ECBC compliant new building should be able to demonstrate minimum energy savings of 25% compared to a conventional building.

**ECBC+ Buildings** shall demonstrate compliance by adopting the mandatory and prescriptive requirements listed under ECBC+ Compliant Building requirements, or by following the provisions of the Whole Building Performance (WBP) Method. ECBC+ Buildings should be able to demonstrate energy savings of 35% compared to a conventional building.

**SuperECBC Buildings** shall demonstrate compliance by adopting the mandatory and prescriptive requirements listed under SuperECBC Compliant Building requirements, or by following the provisions of the Whole Building Performance (WBP) Method. SuperECBC Buildings should be able to demonstrate energy savings of 50% compared to a conventional building.

### 3.4.6 Energy Performance

#### ***Energy Performance Index***

The Energy Performance Index (EPI) of a building is its annual energy consumption in kilowatt-hours per square meter of the building. While calculating the EPI of a building, the area of unconditioned basements is excluded.

$$EPI = \frac{\text{Annual Energy Consumption (in kWh)}}{\text{Total builtup area (excluding unconditioned basement)}}$$

### **EPI Ratio**

The EPI Ratio of a building is the ratio of the EPI of the Proposed Building to the EPI of the Standard Building:

$$EPI\ Ratio = \frac{EPI\ of\ Proposed\ Building}{EPI\ of\ Standard\ Building}$$

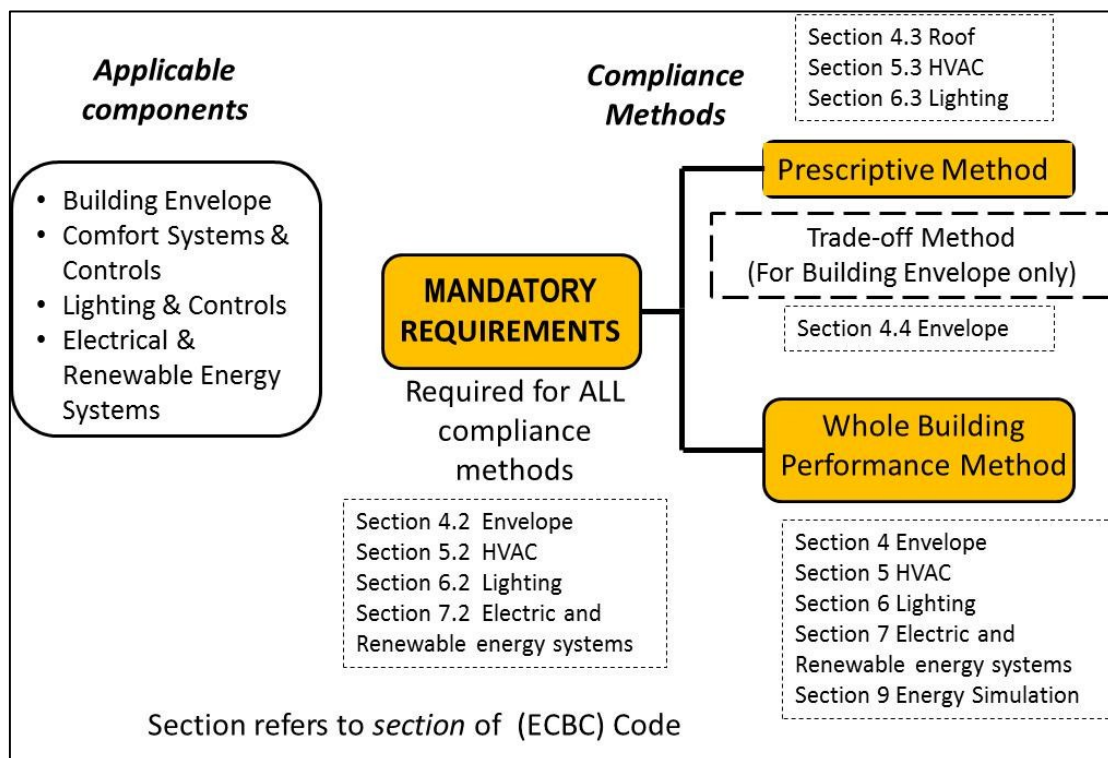
Where,

*Proposed Building* is consistent with the actual design of the building, and complies with all the mandatory requirements of ECBC.

*Standard Building* is a standardized building that has the same building floor area, gross wall area and gross roof area as the Proposed Building, complies with the mandatory requirements, and minimally complies with prescriptive requirements for ECBC Buildings.

### **3.4.7 ECBC Compliance Approaches & Methods**

Two approaches towards ECBC compliance are (a) Prescriptive Method, and (b) Whole Building Performance Method are illustrated in Figure 3.5.



**Figure 3.5: ECBC-Compliance Approach**

#### **(a) Prescriptive Method**

A building complies with the Code using the Prescriptive Method if it meets the prescribed minimum (or maximum) values for envelope components, comfort systems and controls, and lighting and controls, in addition to meeting all the mandatory requirements.

Under Prescriptive Approach, each building/system component should have specific performance value. This approach requires little energy expertise; provides minimum performance requirements and allows no flexibility.

ECBC Buildings that demonstrate compliance through Prescriptive Method shall be considered to have an EPI equal to the Standard Building EPI, and therefore an EPI Ratio of 1.

$$EPI \text{ ratio} = \frac{EPI \text{ (Proposed Building)}}{EPI \text{ (Standard Building)}} = 1$$

It shall also comply with mandatory measures (Sections 4.2, 5.2, 6.2, 7.2 and 8.2) as well as prescriptive requirement (Section 4.3 or 4.4, 5.3 & 7.3)

The EPI Ratio for ECBC+ and SuperECBC Buildings shall be equal to or less than the EPI ratios listed under the applicable climate zone in the Code.

#### **(b) Trade-off Method (for Building Envelope ONLY)**

Building Envelope Trade-off Method may be used in place of the prescriptive criteria of the code. A building complies with the Code using the Building Envelope Trade-off Method if the Envelope Performance Factor (EPF) of the Proposed Building is less than or equal to the EPF of the Standard Building, in addition to meeting the prescriptive requirements for comfort systems and controls, and lighting and controls, and all the mandatory requirements.

Under Trade Off method, component performance value can be less but overall performance of the envelope complies with ECBC. It allows some flexibility through the balance of some high efficiency components with other lower efficiency components

#### **(c) Whole Building Performance Method**

A building complies with the Code using the Whole Building Performance (WBP) Method when the estimated annual energy use of the Proposed Design is less than that of the Standard Design, even though it may not comply with the specific provisions of the prescriptive requirements. However, the mandatory requirements of the code (Sections 4.2, 5.2, 6.2, 7.2 and 8.2 of the ECBC) and specific requirements stated in section 10 shall have to be met.

This approach allows flexibility in meeting or exceeding energy efficiency requirements by optimizing system interactions. It requires component and systems modelling: envelope, lighting, HVAC and for physical processes such as day lighting, heat-flow, airflow.

The EPI of buildings that demonstrate compliance through *Whole Building Performance Method* shall be calculated using the compliance path defined in the code. The EPI Ratio of a building that uses the Whole Building Performance Method to show compliance, should be less than or equal to the EPI Ratio for the applicable building type and climate zone of the

code. A building following this approach shall show compliance through a whole building energy simulation software that has been approved by BEE.

$$EPI \text{ ratio} \leq \frac{EPI \text{ (Proposed Building)}}{EPI \text{ (Standard Building)}}$$

Whole Building Energy Simulation involves predicting energy consumption using software taking into consideration building shape, climate, heat loads, equipment efficiencies etc. Based on hourly calculation of energy consumption, annual energy

### 3.4.8 Case Study of an ECBC-compliant Building

Project function:	Hospitality sector (162 regular rooms and 40 VIP rooms)
Built-up area:	19,875 m <sup>2</sup>
Number of storeys:	Ground + 7 storeys and one basement for parking
Conditioned area:	9,405 m <sup>2</sup> (48% of the built-up area)
Energy Performance Index (EPI) before adopting ECBC:	97 kWh/m <sup>2</sup> /year
EPI after adopting ECBC:	62 kWh/m <sup>2</sup> /year
<b>ECBC-compliant strategies considered:</b>	
<ul style="list-style-type: none"> <li>• Building Envelope: Autoclaved Aerated Concrete (AAC) cavity wall, Overdeck Extruded Polystyrene (XPS) insulation, Heat reflective tiles, Recessed windows, High performance glazing, Unplasticized Polyvinyl Chloride (UPVC) window frame</li> <li>• Lighting: Daylight integration, LED lighting fixtures for interior and exterior lighting</li> <li>• HVAC: Air-cooled Variable Refrigerant Flow (VRF) system</li> <li>• Electric Power: BEE star rated oil based transformer, Automatic Power factor correction panel</li> <li>• Service hot water: 25% of the hot water requirement is met by Solar Water Heaters</li> </ul>	
<b>Cost Details:</b>	
<ul style="list-style-type: none"> <li>• Overall Project Construction Cost : INR 80 crores</li> </ul>	<ul style="list-style-type: none"> <li>• Additional Cost: INR 2,28,86,125               <ul style="list-style-type: none"> <li>– Meeting ECBC Mandatory Provisions: INR 60,00,000</li> <li>– Building Envelope: INR 47,64,045</li> <li>– Lighting: INR 1,09,00,555</li> <li>– HVAC: INR 10,000</li> <li>– Service Hot Water: INR 9,61,525</li> <li>– Electrical Power: INR 2,50,000</li> </ul> </li> </ul>
<ul style="list-style-type: none"> <li>• Reduced cost due to optimised design and reduced sizing for lighting, HVAC, transformer and power back-up, etc.: INR 68,70,000</li> <li>• Incremental Cost: INR 1,60,16,125 (2% of the project construction cost)</li> <li>• Payback Period: 3.8 years [INR 1,60,16,125/[(35 kWh/m<sup>2</sup>.year*19,875 m<sup>2</sup> * INR 6/kWh)]</li> <li>• 570 tCO<sub>2</sub> per year.</li> </ul>	

**Remarks:**

- A significant part of the incremental cost in implementation of ECBC-compliant building gets compensated against the optimized design and reduced sizing for lighting, HVAC, transformer and power, back-up etc.
- ECBC-compliant demonstration projects also show 30–40% energy savings compared to conventional buildings and through energy savings during operation, the incremental cost can be recovered within 3–4 years.

### 3.5 Energy Conservation Building Code (ECBC) for Residential Buildings

ECBC for residential buildings is being launched to help reduce domestic energy consumption. Energy Conservation Building Code (Part I: Building Envelope Design) has been prepared to set minimum building envelope performance standards to limit heat gains (for hot climates) and to limit heat loss (for cold climate) as well as for ensuring adequate natural ventilation and day lighting. The code is applicable to all residential use building projects built on plot area  $\geq 250 \text{ m}^2$ .

The Part I – Building Envelope Design, is the first component of the Energy Conservation Building Code for Residential Buildings to be launched. Its introduction is to improve the construction and design of new residential building stock, as it is being built currently and in the near future, to significantly curtail the anticipated energy demand for comfort cooling in times to come. This critical investment in envelope construction and design made today will reap benefits in terms of reduced energy consumption and thereby operational costs for owners and tenants during the lifetime of the buildings.

The code is designed in a simple-to-apply format, requiring only arithmetic tabulation based on the architectural design drawings of the residential buildings. This will be usable by architects as well as engineers and will not require any specialized skills or simulation softwares. This also enables the Code to be readily adopted in the Building Byelaws and regulatory instruments such as Environmental Clearance for Large Projects.

In the coming years, new components will be added to the Energy Conservation Building Code for Residential Buildings, which will address other aspects such as, Energy Efficiency in Electro-Mechanical Equipment for Building Operation, Renewable Energy Generation, Embodied Energy of Walling Materials and Structural Systems.

#### 3.5.1 Scope of the ECBC (Residential)

The code aims at limiting heat gains/loss from building envelope and for ensuring adequate natural ventilation and day lighting.

To limit the heat gain/loss from the building envelope, the code specifies:

- Maximum value of Residential Envelope Transmittance Value (RETV) for building envelope (except roof) applicable for four climate zones, viz. Composite Climate, Hot and dry Climate, Warm-humid Climate and Temperate Climate.
- Maximum value of thermal transmittance of building envelope (except roof) for Cold Climate zone ( $U_{\text{Envelope,cold}}$ )
- Maximum value of thermal transmittance of roof ( $U_{\text{roof}}$ ) for all climate zones

To ensure adequate natural ventilation, the code specifies

- Minimum Openable window-to-floor area ratio ( $WFR_{\text{op}}$ )

To ensure adequate day-lighting, the code specifies

- Minimum Visible Light Transmittance (VLT) for the non-opaque building envelope components

The code is applicable to all residential use building projects built on plot area  $\geq 250 \text{ m}^2$ . The type of building projects includes, but not limited to:

- Group housing projects: Building unit or units constructed or to be constructed with one or more floors having more than two dwelling units having common service facilities where land is shared and commonly used by the dwelling units, and the construction is undertaken by one agency.
- Mixed Land Use Building projects: With buildings partly used for non-residential uses and partly for residential use.
- Multi-dwelling unit building on residential plots

## 4. ENERGY EFFICIENCY DATA ANALYTICS

### 4.1 Purpose and Background

This chapter serves as an introduction to the concept and principles of Energy Efficiency Data Analytics and its implementation in Indian industry. With potential energy savings ranging from 15–30% in a typical industrial plant, the chapter presents the tools to inform the design of a plant level energy efficiency program based on realistic energy saving targets. Specifically it outlines the importance of data analytics to benchmark performance to enable the design and implementation of industrial energy efficiency programs.

The application of GAP analysis for the key energy intensive industries and comparisons between specific energy consumption (SEC) of Indian industries with global averages and best available technology (BAT) is examined. However, the application of energy efficiency data mining (e.g. Big Data), data modelling and advanced metering infrastructure is beyond the scope of this introductory chapter.

### 4.2 Energy Productivity Indicators

Energy efficiency indicators are key requirement for setting targets and supporting decision makers in establishing energy policies and strategies that are essential in tracking progress. The International Energy Agency (IEA) uses a pyramid of energy productivity (EP) indicators ranging from Economic Scale indicators (GDP/TFC), through sector, sub-sector and industry (specific energy consumption). These indicators can be classified under various levels as shown in Figure 4.1

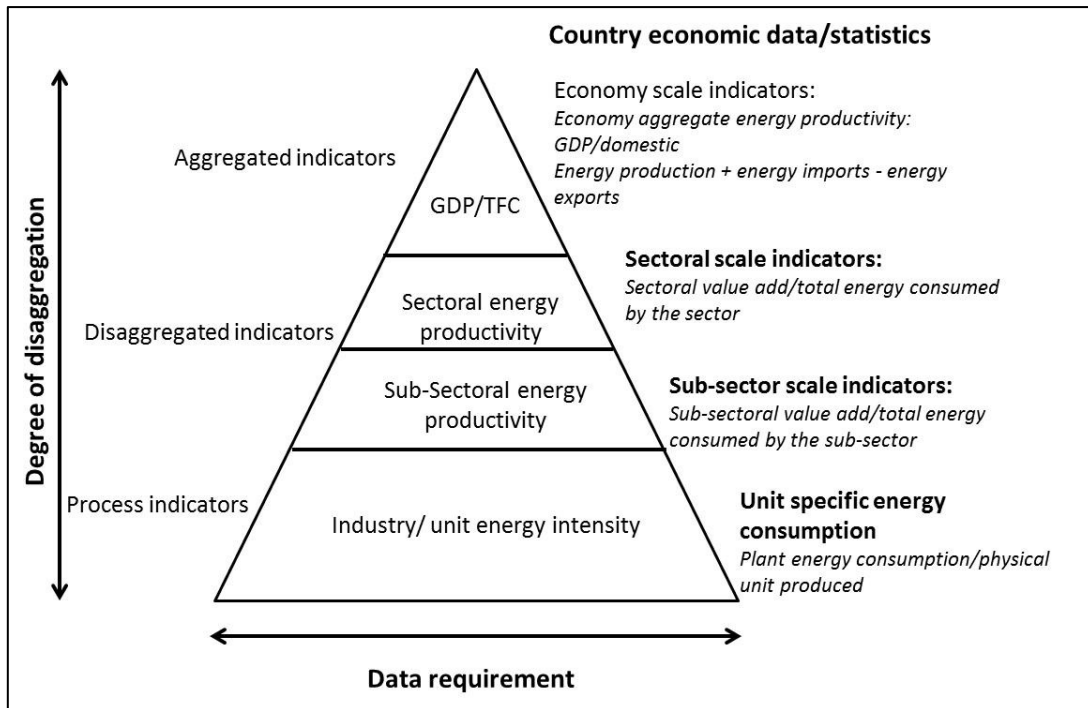
**Level 1:** Economy level aggregate EP indicators defined as the ratio of GDP to National Energy Consumption (defined as domestic energy production + energy imports – energy exports).

**Level 2:** Sector level EP disaggregated indicators defined as the ratio of sector value addition to energy consumed by the sector

**Level 3:** Sub-sector level disaggregated EP indicators defined as the sub sector value addition to energy consumed by the sub-sector.

**Level 4:** Plant level energy efficiency indicators defined as the plant energy consumption divided by the plant output. EE indicators can be further disaggregated to define specific energy consumption by a department or system or equipment in the plant.





**Figure 4.1: Energy Productivity Indicators**

Source: Adapted from IEA energy indicators pyramid

### 4.3 Energy Efficiency Performance Indicators for Industries

The industrial sector is complex and heterogeneous and covers wide range from manufacture of finished goods and products, mining of raw materials, and construction. For the purpose of developing energy efficiency indicators in this chapter, industry refers to the manufacturing sectors covering iron & steel, chemicals & petrochemicals, and cement. The various levels of EE performance indicators for industries are illustrated in Figure 4.2 and details are given in Table 4.1.

**Table 4.1: Energy Efficiency Performance Indicators<sup>1</sup> for Indian Industry**

Sector/sub-sector	Coverage	Typical Process Energy End-Use	Energy Data	Output Data	EE Performance Indicator
All Industry	<b>Sub-sectors</b> Iron & Steel Fertilizers Chemicals & Petrochemicals Cement Aluminum	Heating Lighting Cooling Motive power (pumps, fans, blowers, dryers, compressors, conveyors etc) Electrolysis	Total industry sector energy consumption  Total sub-sector energy consumption	Industry value added  Sub-sectoral economic (value added) or physical output	<b>Level 1</b> Total industry energy consumption per total industry value added  <b>Level 2</b> Sub-sectoral energy consumption per unit of sub-sectoral physical output
Iron & Steel	Basic Oxygen Process	Heating Motive power	Plant energy consumption	Plant manufactured output	<b>Level 3</b> Process/product energy consumption per unit of

<sup>1</sup> Also referred to as energy intensity or specific energy consumption (SEC) in industry.

	(BOF) Electric Arc Furnace (EAF)  Direct Reduction Iron (DRI)	Lighting	Dept. or section or equipment energy consumption	Dept/section physical output	physical output  <b>Level 4</b> Plant specific energy consumption at a department/section/equi pment level
Chemicals & Petrochemicals	Ethylene Benzene, Toluene, Xylene (BTX) Ammonia Methanol Butadiene	Heating (distillation, drying, evaporation) Motive power Lighting Chillers	Plant energy consumption  Dept. or section or equipment energy consumption	Plant manufactured output  Dept/section physical output	<b>Level 3</b> Process/product energy consumption per unit of physical output  <b>Level 4</b> Plant specific energy consumption at a department/section/equi pment level
Cement	Clinker (wet and dry);	Heating (calcination, drying) Motive power Lighting	Plant energy consumption  Dept. or section or equipment energy consumption	Plant manufactured output  Dept/section physical output	<b>Level 3</b> Process/product energy consumption per unit of physical output  <b>Level 4</b> Plant specific energy consumption at a department/section/ equipment level

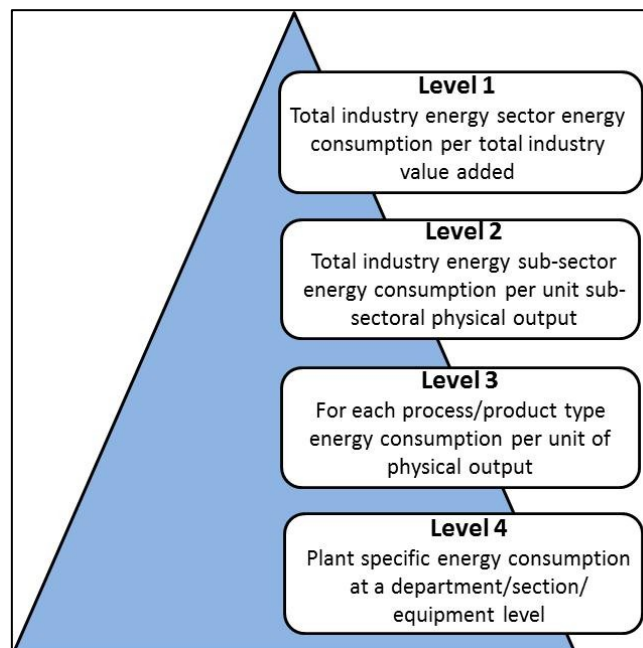


Figure 4.2: Pyramid of Energy Efficiency Performance Indicators for Industries

#### 4.4 Benchmarking of Sectoral Energy Efficiency

Benchmarking is the process of accounting for and comparing a metered industrial facility's current energy performance with its energy baseline or with the energy performance of similar types of industry. The United Nations Industrial Development Organization (UNIDO)

benchmarked the energy efficiency potential for 26 industrial sub-sectors globally by looking at sector specific indicators of performance in terms of energy per unit of output (UNIDO 2010) (Table 4.2).

The study broke down the results in developing and developed countries and also presented figures for the global average, the lowest found in the sample and the achievable performance using Best Available Technology (BAT).

**Table 4.2: Specific Energy Consumption in Industry – India and the World**

Sectors	Units	Industrialized Countries	Developing Countries	Global Average	Best Available Technology	India
<i>Petroleum refineries (2003)</i>	Energy Efficiency Index (EEI)	0.7-0.8	1.3-3.8	1.25	1	0.9
<i>High value(HVC)</i>	Gj/t HVC	12.6-18.3	17.1-18.3	16.9	10.6	17.1
<i>Ammonia(2007)</i>	Gj/t NH <sub>3</sub>	33.2-36.2	35.9-46.5	41	23.5	37.5
<i>Methanol(2006)</i>	Gj/tMeOH	33.7-35.8	33.6-40.2	35.1	28.8	40.2
<i>Aluminium smelting (2007)</i>	MWh/t	14.8-15.8	14.6-15	15.5	13.4	16
<i>Alumina Production</i>	Gj/t alumina	10.9-15.5	10.5-24.5	16	7.4	
<i>Iron &amp; steel (2005)</i>	EEI	1.16-1.4	1.4-2.2	1.45	1	1.55
<i>Clinker (2007)</i>	Gj/t clinker	3.3-4.2	3.1-6.2	3.5	2.9	3.1
<i>Cement (2 007)</i>	Gj/t cement	109-134	92-121	109	56	92
<i>Lime</i>	Gj/t lime	3.6-13	5-13	-	-	5.6
<i>Glass (2005)</i>	Gj/t melt	4-10	6.8-7.8	6.5	3.4	6.8
<i>Brickmaking (2000s)</i>	Mj/kg fired brick	1.5-3	0.75-11	-	-	3-11
<i>Pulp and Paper</i>	EEI (heat & electricity)	0.93-1.73	0.43-2.29	1.31	1	
<i>Textiles Spinning</i>	Gj/t yarn	Ring yarn: 3.5-3.6 Open end: 2.57	Ring yarn: 3.5-3.6 Other: 0.5-7.5	- - -	- - -	Ring yarn: 3.57 2.5
<i>Weaving</i>	Gj/t cloth	11-65	5-43	-	-	27-32.4
<i>Cast iron</i>	kWh/t melt	Cupola: 950 Electric: 525-715	780-850		520	780-900
<i>Cast/alloy steel</i>	kWh/t melt	Electric: 525-715				
<i>Cast aluminium</i>	kWh/t melt	Fuel-fired: 600-1250 Electric: 440-590	735		500	735
<i>Cast copper</i>	kWh/t melt	Electric: 400-1100	590		570	590

Source: Data drawn from *Global Industrial Energy Efficiency Benchmarking – An Energy Policy Tool: Working Paper*, UNIDO, Nov. 2010

## 4.5 Plant Energy Efficiency Data Analytics

Energy Performance Indicators (EnPIs) are an important tool for measuring the energy efficiency of industrial processes and services. They provide inputs for developing energy efficiency policies, establishing targets, assessing and calculating potential for energy savings, and understanding past trends in energy use. In addition, they can also be used to model and forecast future energy demand. A sound systemic approach to metering, measurement, collecting, recording and analysing data is the foundation on which industrial energy efficiency policies and target setting are established.

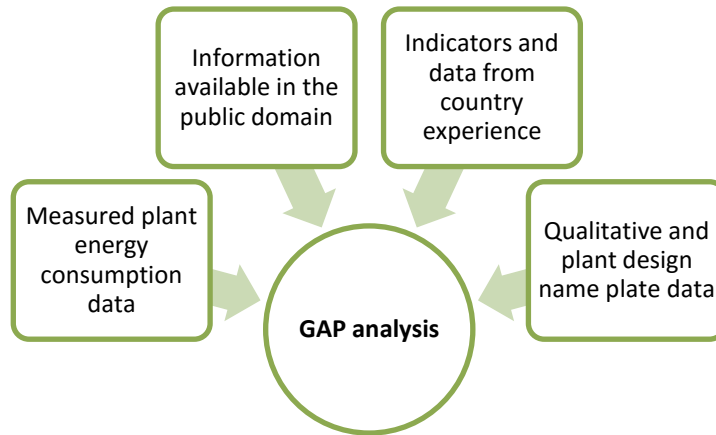
Energy efficiency data analytics performs a vital task of placing “facts on the table” which enable industry corporates to design and implement energy savings programs and for policy makers to formulate realistic plans. At the plant level these indicators are developed through the deployment of Energy Information Management and Analytics System (EIMAS). At the industry sub-sector level, they require the establishment of a cloud-based centralized energy efficiency data repository (CEEDR) that integrates the EIMAS of participating companies to provide EnPI-driven dashboard that could be used by government to formulate industrial energy productivity policies and design programs. It is therefore necessary to prioritize the development of energy efficiency indicators to support policy formulation and its implementation. In this context GAP analysis is the first step towards prioritization and selection of the most cost-effective strategy.

### **Prioritisation through GAP analysis**

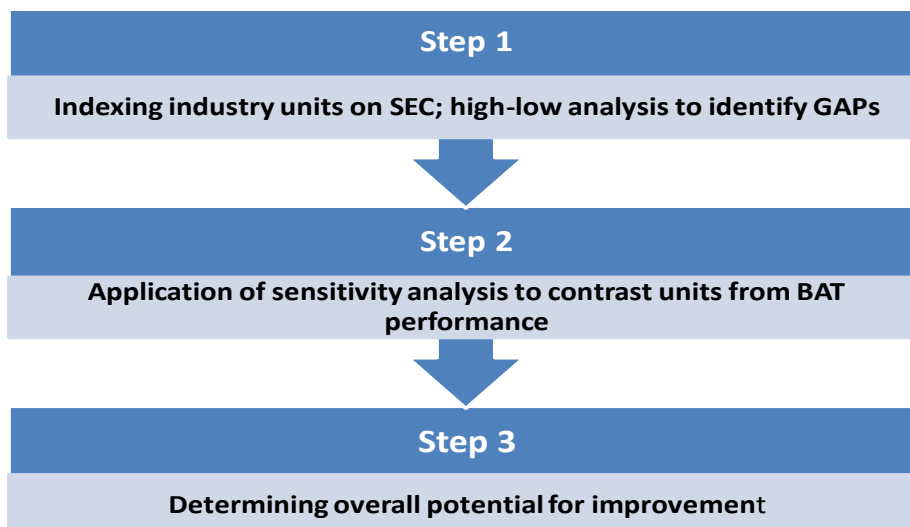
Priorities need to be set for both country level energy efficiency policies and plant level programmes. Within most countries, and industries, a small number of enterprises account for a large proportion of total industrial or sector consumption. The priorities should be to focus on improving the performance of inefficient and large energy consuming industries whilst not forgetting that even the most efficient industries and firms can continually improve.

A starting point for setting priorities is the current level of performance as demonstrated by national and international benchmarking using gap analysis. Gap analysis is a benchmarking process that accounts for and compares a plant’s current energy performance with that deploying Best Available Technologies (BAT).

A plant’s Specific Energy Consumption (SEC) is typically the performance indicator used in comparing an industry’s energy efficiency performance and also in laying down unit/sector specific energy performance targets. GAP analysis begins with first collating information from public sources on the pattern of sub-sectoral energy consumption at the regional, country and local levels. This is further augmented and refined by measured plant level energy performance data including plant design data as shown in Figure 4.3. The Figure 4.4 outlines the steps involved in performing GAP analysis.



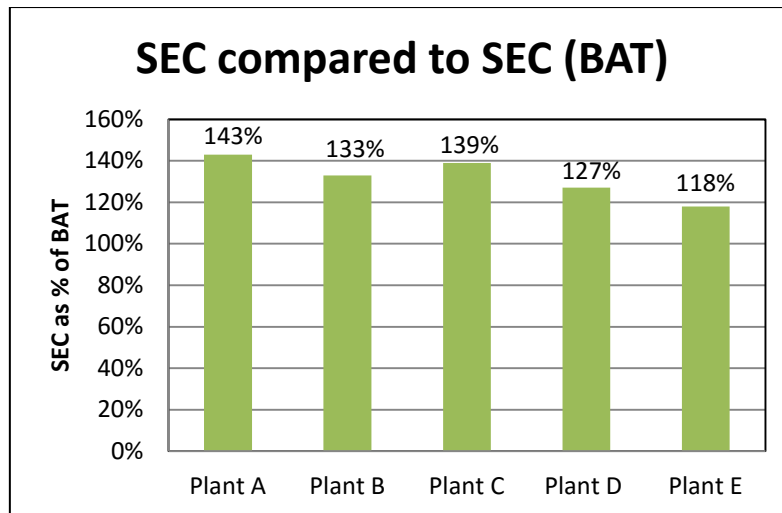
**Figure 4.3 Data Sources for GAP analysis**



**Figure 4.4: GAP Analysis Steps**

The GAP analysis of SEC among industrial units in a region, country or cluster sets the stage developing a system of prioritization and setting benchmarks and targets.

For illustration purposes SEC of 5 industrial plants or units of any particular sub-sector have been computed as % of the SEC (BAT). This is shown in Figure 4.5.

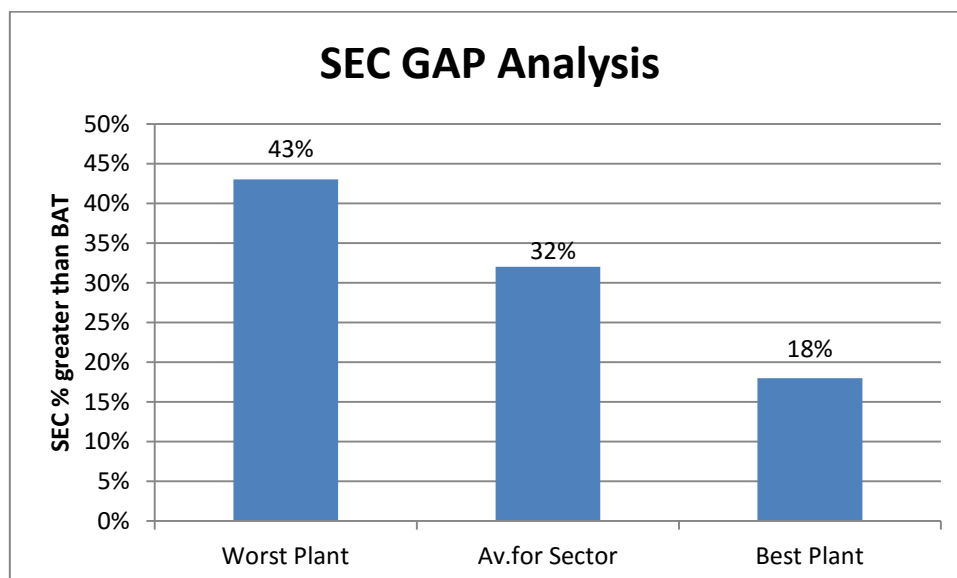


**Figure 4.5 : SECs Compared with SEC (BAT)**

As one can see from Figure 4.5 the best performing industrial unit (E) is 18% higher than SEC (BAT), whereas the worst unit (A) has an SEC of 43% higher than the SEC (BAT). The SEC for the particular sector (average of all units), is around 32% higher than the SEC (BAT).

The gap analysis sets the stage for establishing energy reduction targets (Figure 4.6). It is therefore important to note that the stipulation of energy savings targets for any particular sub-sector and/or industrial plant is derived from the energy savings potential that the sub-sector or plant has with regard to BAT.

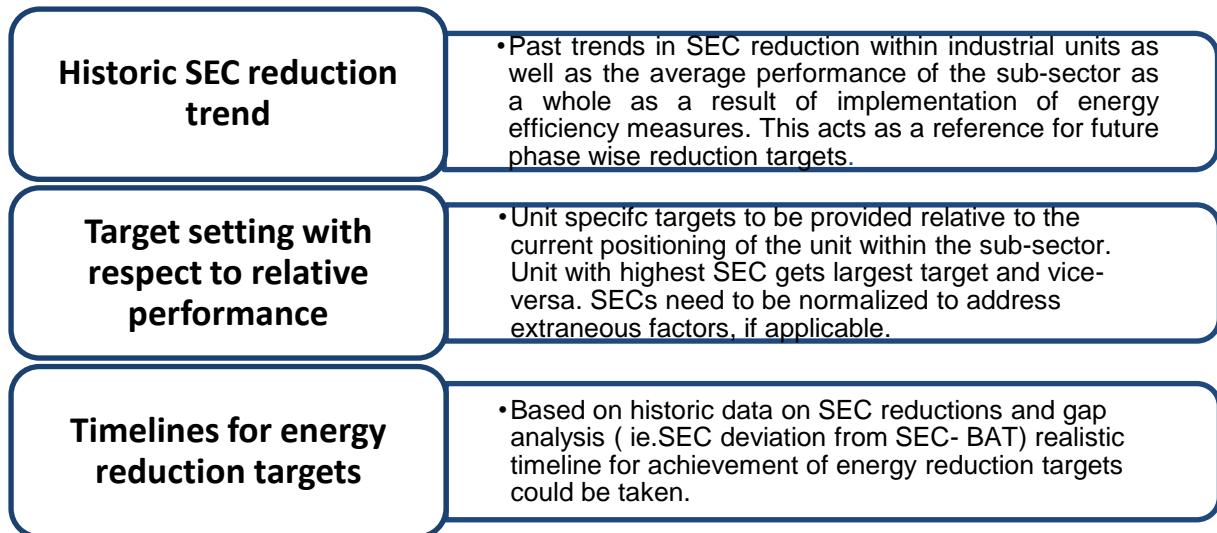
It follows logically that the formulation of effective energy productivity policies and programs and related performance targets is critically dependent upon the availability of quality data sets pertaining to unit performance in terms of SEC.



**Figure 4.6 : Prioritization through GAP analysis**

## Target setting

Once the GAP analysis is completed the subsequent step is to lay down reduction targets for each unit and the associated timelines for each reduction phase. This is shown in Figure 4.7 below.

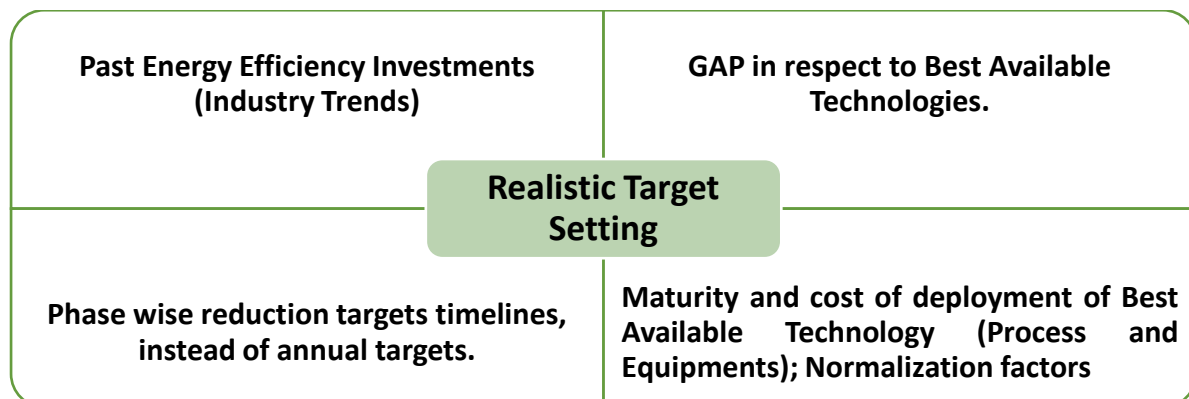


**Figure 4.7: Steps for Target Setting**

## Setting Realistic Targets

Target setting, timelines and fiscal incentives are all interdependent and each needs to be defined in respect to the other. The key is to ensure that the targets set are neither too low nor thus too easy to meet nor too stringent; both can have a negative impact on the success of the energy efficiency policy of the government.

To ensure realistic target setting is to assess four key factors that influence the growth and deployment of efficiency measures in industry. The graphic below (Figure 4.8) provides the key factors and their influence in driving the EE market.



**Figure 4.8: Realistic Target Setting**

## Normalization

There are several factors that affect the SEC of a unit which are sometimes beyond the control of the company. Such causes need to be assessed and a correction factor needs to be assigned on a unit by unit basis using sub-sector specific normalization values to adjust the SEC targets and determine the level of compliance. Normalization is essential to ensure a level playing field when establishing SEC targets. The indicative normalization factors to be considered for adjustment of SEC targets are represented in Figure 4.9.

Primary Energy Input	Secondary Energy Input	Capacity Utilization Factor	Raw material and product output	Environmental Standards
<ul style="list-style-type: none"> <li>• Fuel quality</li> <li>• Use of biomass as fuel</li> <li>• Use of byproducts as fuel</li> <li>• Non-availability of fuel</li> </ul>	<ul style="list-style-type: none"> <li>• Grid power purchase</li> <li>• Captive power generated</li> <li>• Waste heat recovered</li> <li>• Export to grid</li> <li>• Use of renewable energy</li> </ul>	<ul style="list-style-type: none"> <li>• Impact of market demand</li> <li>• Non-availability of raw materials</li> <li>• Quality of power supply</li> </ul>	<ul style="list-style-type: none"> <li>• Quality of raw materials</li> <li>• Change in output product mix</li> <li>• Change in inputs</li> </ul>	<ul style="list-style-type: none"> <li>• Change in product standards</li> <li>• Change in Government Policy</li> <li>• Force Majeure issues</li> </ul>

**Figure 4.9 Normalization Factors for Adjusting SEC Targets**

## Example of Target Setting

Data given below is for a group of Textile Spinning Units in Northern India manufacturing synthetic yarns. Gap between average SEC and the BAT-SEC is around 23.1%. At increased SEC reduction (to be facilitated by the government policy and internal industry targets) of 2% annually the group is expected to take around 8 years to come to the level of BAT, as per its current standards. Only 35%-40% of the gap could be covered by retrofits, equipment efficiency improvements etc, that was financed through internal resources. Majority of the gap had to be filled by deployment of BAT which is capital intensive and needs fiscal incentives.

Description	Values
Industry average SEC	0.9
Industry average SEC (after normalization)	0.825
SEC Best Available Technology (SEC-BAT)	0.67
SEC GAP	23.1%
Average annual SEC reduction	2%
Timeline to reach BAT levels of SEC	8 years
Suggested annual increase in SEC	50%
Revised timeline to reach BAT levels of SEC	4 years



#### 4.6 Importance of “Data” in conducting Gap Analysis

Allocation of energy saving targets for any particular sub-sector could typically be derived from the energy saving potential that the sub-sector has with respect to Best Available Technology. For that to happen an effective Industrial Energy Efficiency Policy has to have access to quality data sets pertaining to a unit’s specific Key Performance Indicators (KPIs) for that particular sector.

Figure 4.10 shows the plot of SEC for Aluminum Refinery units, we can see 200% difference between the best and worst SEC. However that is not a true indication of the energy efficiency improvement potential. Technologies used in all these units is not the same which means that even though they are from the same sector, it is inappropriate to use the SEC figures without normalization of KPIs.

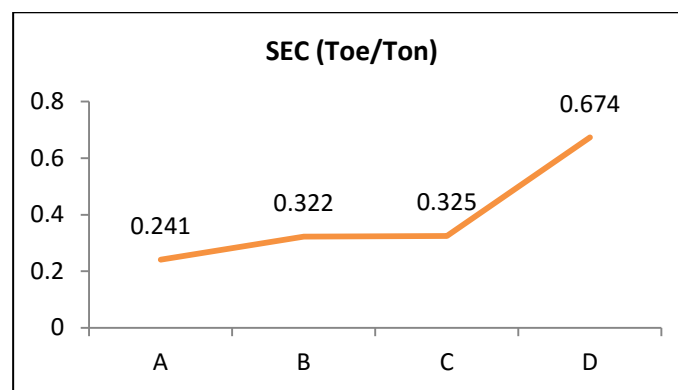


Figure 4.10: Variation of SEC for Alumina Refinery Units

It is important to look at bandwidth of the data and not just the yearly average figures, which might not be the true reflection of the plant performance and hence lead to incorrect benchmarking and target setting.

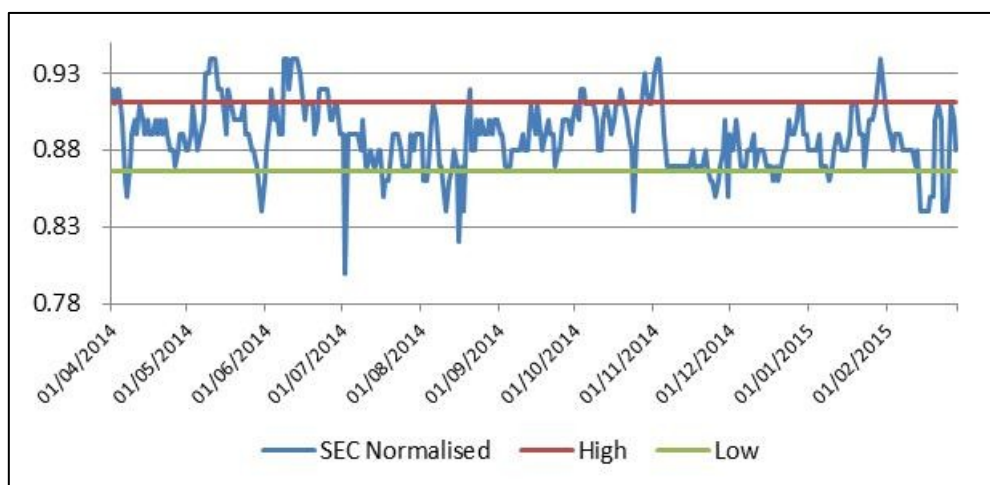


Figure 4.11 Importance of Normalizing data before Gap Analysis<sup>1</sup>

### **Target Setting**

Once the GAP analysis is done, the second step is to lay down reduction targets for each unit and subsequently the timelines for each reduction.

### **Institutionalizing Data Analytics**

Energy productivity performance data management requires the establishment of plant or unit level Energy Information Management Analytic System (EIMAS) that meters, measures, records and analyzes key performance indicators such as SEC of production departments and/or entire plants. Furthermore the EIMAS in an individual unit could also be linked to a Centralized Energy Efficiency Data Repository (CEEDR) operated through a web-based cloud portal providing policy makers and corporates with salient, actionable information on a real time basis on the energy productivity performance of the industry.

## **4.7 Energy Information Management and Analytical Systems (EIMAS)**

EIMAS could be a powerful tool to measure and compute energy performance indicators (EnPIs) that drive industrial energy efficiency projects and programs and should be a key focus area for industrial companies to establish. The EIMAS offers the following benefits to its users:

- Access to centralized data, and strengthened and effective management information system.
- EnPI-driven information and performance analysis.
- Useful insights and predictive analysis to serve as metrics that improve shop floor energy performance and productivity.
- Real-time management and optimized use and control of end-use energy in utilities and process departments.
- Easy, quick, and timely reporting of energy performance.

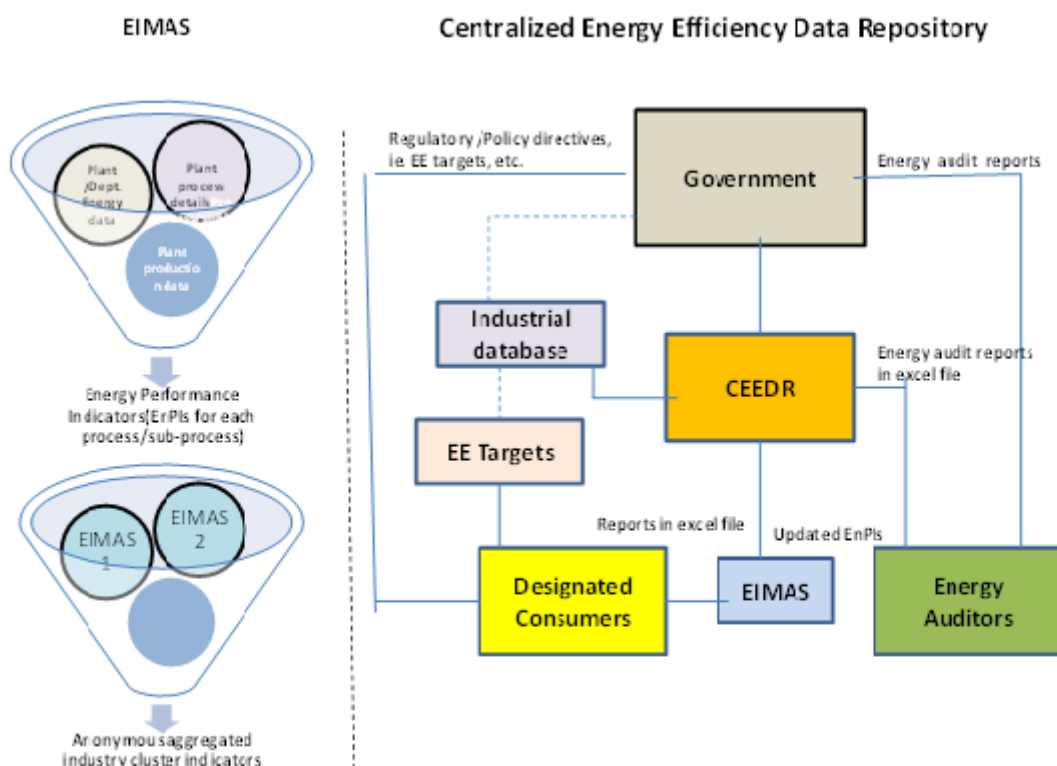
EIMAS can be designed and implemented in an industry sub-sector (i.e. cement or steel) and can be extended to other energy-intensive sectors, such as fertilizers, chemicals, and petrochemicals.

## **4.8 Centralized Energy Efficiency Data Repository**

While the EIMAS is an organisation or plant level energy management structure, its relevance extends well beyond the facilities under its purview. It could serve as a building block for policy makers to design and implement sector and sub-sector level energy savings targets, monitor and verify their progress and provide strategic support and regulatory oversight. The consolidation of company level EIMAS data and its analysis could serve as the basis and foundation of a centralized energy efficiency data repository (CEEDR). The CEEDR in key industry sub-sectors managed by respective industry associations or any other acceptable arrangement that guarantees security of data could serve as a key resource and platform for a data driven national industrial EE program. The CEEDR offers the following benefits:

- An integrated assessment of the energy performance of the sector.
- An effective tool for monitoring and verification of energy performance trends (for example, a specific energy consumption metric, such as a unit (kilowatt-hour) per kilogram of production) at the sector, subsector, unit, department, process, and equipment levels.
- Based on normalized EnPIs, different units are ranked and compared, and gaps in specific energy consumption are identified.
- Useful in planning future policies to improve the energy efficiency of the sector as a whole.

Regulation to mandate monthly EnPI filings through the use of EIMAS, linked to the CEEDR, is recommended. Figure 4.11 provides the linking of plant level EIMAS with CEEDR.



**EnMS at the Organisational level and Centralized EE benchmarking at the Industry sub-sector level**

**Figure 4.12: EIMAS and CEEDR Linkage**

#### 4.9 Policies to Support Industrial Energy Efficiency

Since industry accounts for a high proportion of energy use in India, having effective policies that assist industrial enterprises to improve levels of energy efficiency (and hence energy productivity) should be a priority. Over the past few decades industrial energy efficiency policy formulation has evolved considerably with program designs reflecting analytical practices that reflect increasing methodological sophistication. A number of inter-related factors need to be considered by policy makers and a step-by-step program employing

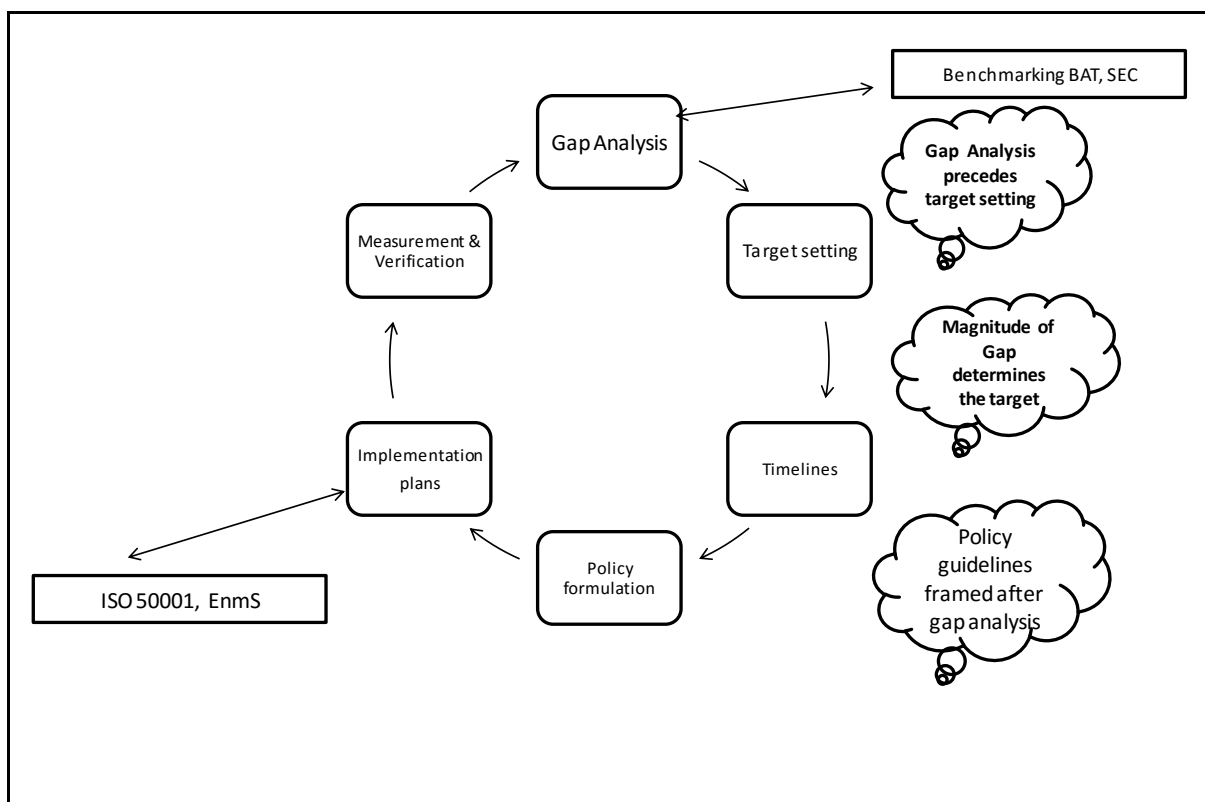
analytical and system planning tools and methods are presented in Table 4.3 as the policy map towards advancing industrial energy productivity in India.

**Table 4.3: Energy Efficiency Policy & Program Pathway in Indian Industry Sector**

Phases	Steps	Actions	Tools
Policy Definition	Introduce industrial EP regulations in legislative framework	<ul style="list-style-type: none"> <li>Analyze legislative framework and regulatory drivers</li> </ul>	<ul style="list-style-type: none"> <li>GAP analysis</li> <li>SEC norms</li> </ul>
Program Planning	Define policy framework	<ul style="list-style-type: none"> <li>Analyze policy framework and industrial context</li> </ul>	
	Design program	<ul style="list-style-type: none"> <li>Define scope and objectives</li> <li>Define Energy Management System (EnMS)</li> </ul>	<ul style="list-style-type: none"> <li>ISO 50001: Energy Management System</li> </ul>
	Establish Action Plans	<ul style="list-style-type: none"> <li>Establish Energy Information Management Analytic System (EIMAS)</li> <li>Create Centralized Energy Efficiency Data Repository (CEEDR)</li> </ul>	
Program Implementation	Provide Institutional support	<ul style="list-style-type: none"> <li>Conduct energy audits; Energy performance contracting (ESCO)</li> <li>Develop training strategy :institutional and human capacity</li> <li>Follow-up with companies and assist in implementation</li> </ul>	<ul style="list-style-type: none"> <li>Energy audit tools &amp; practices</li> </ul>
Monitoring & Evaluation	Establish M&E protocols	<ul style="list-style-type: none"> <li>Establish verifiable indicators and data sources</li> <li>Setup meter &amp; sub-meter facilities</li> <li>Establish baselines</li> <li>List best practice technologies</li> <li>Develop and monitor plant energy performance indicators</li> </ul>	<ul style="list-style-type: none"> <li>Benchmarking</li> <li>BAT/BPT analysis</li> </ul>
	Assess compliance; feedback correction	<ul style="list-style-type: none"> <li>Use transparent &amp; predefined criteria</li> <li>Establish rewards or penalty mechanisms</li> </ul>	
	Evaluate program	<ul style="list-style-type: none"> <li>Define evaluation objectives</li> <li>Select evaluation approach and indicators</li> </ul>	
Reporting	Promote program	<ul style="list-style-type: none"> <li>Address challenges and failures</li> </ul>	
	Revise and adapt program.	<ul style="list-style-type: none"> <li>Adjust program design and consider up-scaling</li> </ul>	

## Program Planning

The Figure 4.12 shows the overview of industrial energy productivity policy planning and implementation process. An important point to note is that policy directives in the form of energy target reduction or mandating energy audits and reporting is a consequence of and derived from the findings of the gap analysis and target setting exercise at the sectoral, sub-sector and unit levels. Once the policies have been formulated, governments need to provide the enabling climate that assist industries in adhering to the policy requirements and plan for sustained energy efficiency/productivity improvements. The implementation plan needs to be technology, market and business driven and draws upon EnMS systems (e.g. ISO 50001) that require data analytics and includes institutional development and capacity building as well.



**Figure 4.13: Industrial Energy Productivity Policy Planning and Implementation Process**

## 5. ENERGY MANAGEMENT SYSTEM (EnMS): ISO 50001: 2018

### 5.1 Introduction

Energy management makes good business sense as energy costs is a significant portion in an organisation's budget. Individual organization cannot control energy prices, government policies or the global economy, but they can very well improve the way they manage energy in their organizations.

A systematic focus on energy management, through optimum use of resources and reduction in wastes, is expected to reduce cost. It can also lead to increased production, improved energy performance, higher profits, and reduced impacts due to rising energy prices. A reduction in energy consumption will also lower CO<sub>2</sub> emissions to the environment, and the organisation thereby contributes its part to addressing the climatic change objectives of the country.

Despite these opportunities for energy savings and efficiency improvements, organisations hesitate implementing measures and reaping the benefits of potential reduction in operation costs. Most companies do not understand how much energy they currently use and how much they potentially save by implementing an Energy Management System. Another barrier in achieving energy savings is the lack of commitment at all levels, especially top management in the organization, to make changes necessary to achieve these improvements.

In order to manage energy well, an organization requires an effective Energy Management System (EnMS) to be established, implemented, maintained and continually improved. There are two ways to doing it; they can develop and implement their own Energy Management System or they can implement Energy Management System conforming to ISO 50001.

### 5.2 Why ISO 50001 to Manage Energy Effectively?

It is in the interest of the organizations to implement ISO 50001 since it is based on the management system model that is already well-understood and implemented by organizations worldwide. It can make a positive difference for organizations of all types immediately even without any investment, while supporting longer term efforts for capital intensive energy-efficient technologies.

In order to spur interest in energy efficiency and help organisation take appropriate actions to overcome barriers in implementing practical energy saving measures, International Organisation for Standardisation (ISO) had released the first version of '**ISO 50001 Energy Management Systems (EnMS)–Requirements with guidance for use**' in June 2011 and revised version of **ISO 50001:2018** in August, 2018.

### 5.2.1 Energy Performance Approach

The standard provides requirements for a systematic, data-driven and facts-based process, focused on continually improving energy performance. Energy performance is a key element integrated within the concepts introduced in the standard in order to ensure effective and measurable results over time. Energy performance is a concept which is related to energy efficiency, energy use and energy consumption.

ISO 50001 has made a major leap in 'raising the bar' by requiring an organization to demonstrate improved energy performance. There are no quantitative targets specified; an organization can choose its own targets and create an action plan to meet the targets. With this structured approach, an organization is more likely to see tangible financial benefits. Energy Performance Indicators (EnPIs) and energy baselines (EnBs) are two interrelated elements addressed in the standard to enable organizations to demonstrate energy performance improvement.

### 5.2.2 Relationship between Energy Performance and the EnMS

The ISO 50001 standard addresses both energy performance improvement and management system approach to manage energy. The standard requires continual improvement of EnMS as well as energy performance to achieve intended outcomes. Accordingly, the EnMS promotes, supports and sustains the Energy Performance Improvement, achievement of other intended outcomes, and its continual improvement of EnMS as illustrated in Figure 5.1.

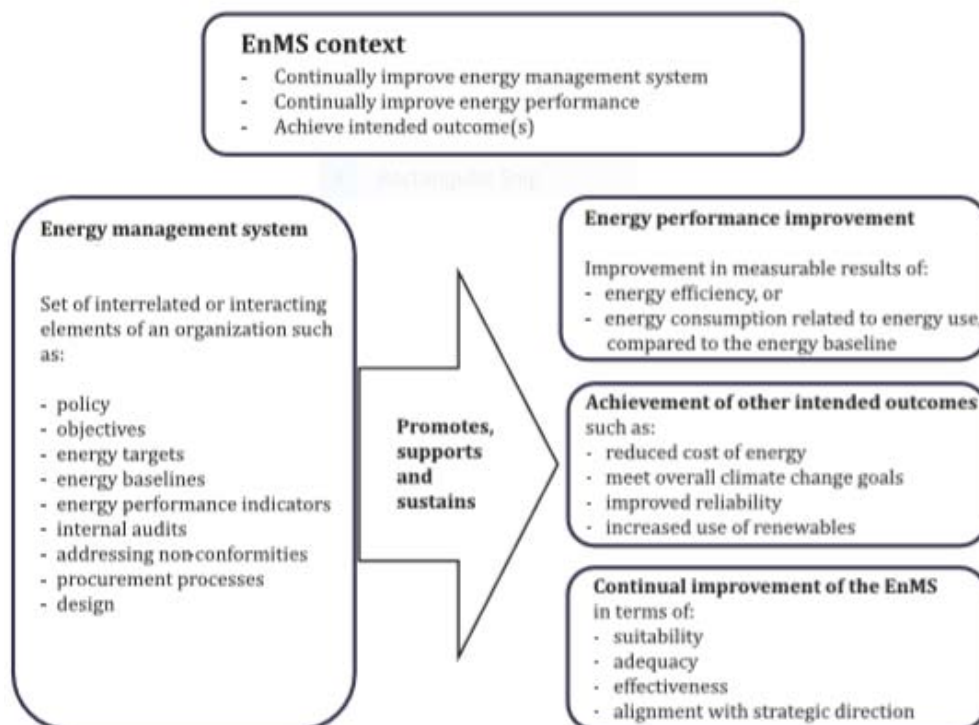


Figure 5.1 – Relationship between EnMS and Energy Performance

### 5.2.3 Plan-Do-Check-Act (PDCA) cycle

The EnMS described in the standard is based on the Plan-Do-Check-Act (PDCA) continual improvement framework and incorporates energy management into existing organizational practices as illustrated in Figure 5.2.

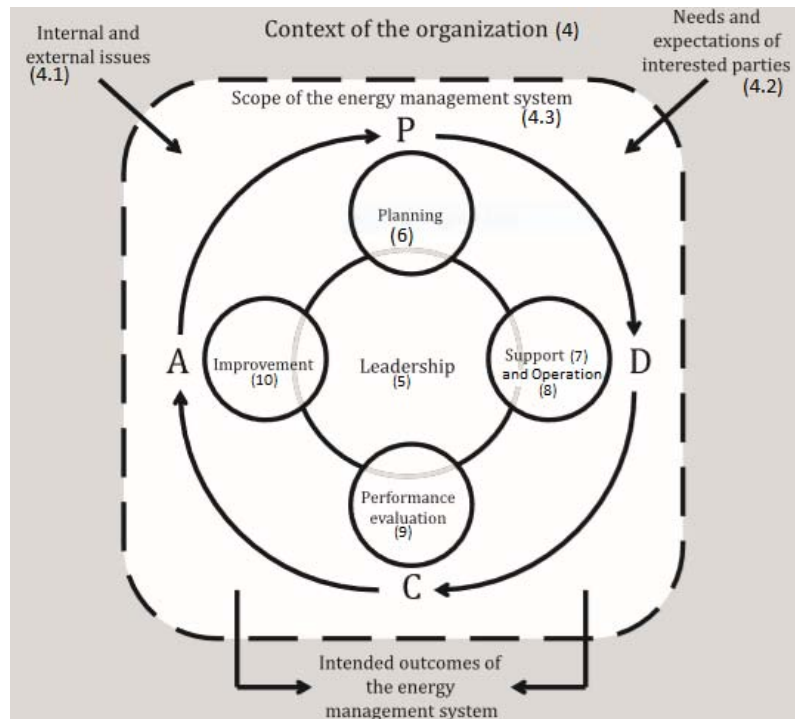


Figure 5.2 – PDCA cycle

#### The PDCA Approach to EnMS

**Plan:** understand the context of the organization, establish an energy policy and an energy management team, consider actions to address risks and opportunities, conduct an energy review, identify significant energy uses (SEUs) and establish energy performance indicators (EnPIs), energy baseline(s) (EnBs), objectives and energy targets, and action plans necessary to deliver results that will improve energy performance in accordance with the organization's energy policy.

**Do:** implement the action plans, operational and maintenance controls, and communication, ensure competence and consider energy performance in design and procurement.

**Check:** monitor, measure, analyse, evaluate, audit and conduct management review(s) of energy performance and the EnMS.

**Act:** take actions to address nonconformities and continually improve energy performance and the EnMS.



### 5.3. Benefits of Implementing ISO 50001

The implementation of ISO 50001 will provide the following benefits:

- a) provide organizations with a well-recognized framework for integrating energy efficiency into their management/business practices,
- b) provide a logical and consistent methodology for identifying and implementing improvements that can contribute to a continual increase in energy efficiency across the facilities,
- c) assist organizations to better utilize existing energy consuming assets, thus reducing costs and/or avoiding expanding capacity,
- d) offer guidance on benchmarking, measuring, documenting, and reporting energy efficiency improvements
- e) lead organizations to meet overall climate change mitigations goals by reducing their energy related greenhouse gas emissions,
- f) assist facilities in evaluating and prioritizing implementation of state-of-the-art energy-efficient technologies,
- g) provide an approach for organizations to encourage suppliers to better manage their energy, thus promoting energy efficiency throughout the supply chain.

### 5.4 Why a New ISO 50001 Version?

It is a part of continual improvement that every management standard is periodically reviewed. This version change is driven by high-level structure (HLS) implementation. The purpose of HLS is to make ISO 50001 comparable and compatible to other standards such as ISO 9001:2015 and ISO 14001:2015. This will help organization implementing or maintaining Integrated Management System (IMS).

The new version is targeted to build energy culture in an organization. Adoption of HLS is expected to make process owner more responsible for all systems rather than a single management system. Salient feature of HLS:

- A common structure for all Standards (ISO 9001, ISO 14001) etc
- 10 clauses in all
- HLS structure + energy management specific clauses

All ISO Standards will henceforth follow ten clauses recommended by HLS and few additional clauses which are specific to that particular standard.

The new version also brings risk management approach—risk management, risk analysis—in energy management system.

The main changes compared to the previous version of ISO 50001:2011 are as follows:

- (i) adoption of ISO's requirements for management system standards, including a high-level structure, identical core text, and common terms and definitions, to ensure a high level of compatibility with other management system standards;
- (ii) better integration with strategic management processes;

- (iii) clarification of language and document structure;
- (iv) stronger emphasis on the role of top management;
- (v) inclusion of new definitions, including energy performance improvement;
- (vi) clarification on exclusions of energy types;
- (vii) clarification of “energy review”;
- (viii) introduction of the concept of normalization of energy performance indicators [EnPI(s)] and associated energy baselines [(EnB(s))];
- (ix) addition of details on the energy data collection plan and related requirements (previously energy management plan): and
- (x) clarification of text related to energy performance indicators [EnPI(s)] and energy baselines [EnB(s)].

*The chapter numbers from here onwards are revised to match with Clause Numbers of ISO 50001:2018 standard to avoid any confusion. This chapter clarifies the requirements of the standard and how to meet those. To know the exact requirements under each clause, ISO 50001:2018 standard should be referred.*

#### **Interpretation of key words used in the standard**

In the new standard, “shall” indicates a requirement; “should” indicates a recommendation; “can” indicates a possibility or a capability; and “may” indicates permission.

Besides, it should be remembered that

- (i) the use of the word “any” implies selection or choice,
- (ii) the words “appropriate” and “applicable” are not interchangeable. “Appropriate” means suitable (for, to) and implies some degree of freedom, while “applicable” means relevant or possible to apply and implies that if it can be done, it needs to be done,
- (iii) the word “consider” means it is necessary to think about the topic but it can be excluded, whereas “take into account” means it is necessary to think about the topic but it cannot be excluded, and
- (iv) the word “ensure” means the responsibility can be delegated, but not the accountability.

#### **Requirements of ISO 50001:2018**

- 1 Scope** – Gives scope of the standard.
- 2 Normative references** – There are no normative references in this document.
- 3 Terms and definitions** – Gives definitions of various terms used. In new version, definitions have been divided into five categories and in place of 28 definitions in the old version; there are 41 definitions in new version.

## **4 Context of organization**

### **4.1 Understanding the organization and its context**

The organization is required to determine external and internal issues that are relevant to its purpose and that affect its ability to achieve the intended outcome(s) of its EnMS and improve its energy performance. The analysis of organizational context will provide a high-level conceptual understanding of the external and internal issues that can affect, either positively or negatively, energy performance and the EnMS of the organization.

External issues could be related to interested parties such as existing national or sector objectives, requirements or standards; restrictions or limitations on energy supply, security and reliability; energy costs or the availability of types of energy; effects of weather; effects of climate change; effect on greenhouse gas (GHG) emissions etc.

Internal issues could include core business objectives and strategy; asset management plans; financial resource (labour, financial, etc.) affecting the organization; energy management maturity and culture; sustainability considerations; contingency plans for interruptions in energy supply; maturity of existing technology etc.

### **4.2 Understanding the needs and expectations of interested parties**

Under this clause, the organization is supposed to identify the interested parties that are relevant to energy performance and the EnMS; the relevant requirements of these interested parties; and which of the identified needs and expectations need to be addressed by the organization through its EnMS.

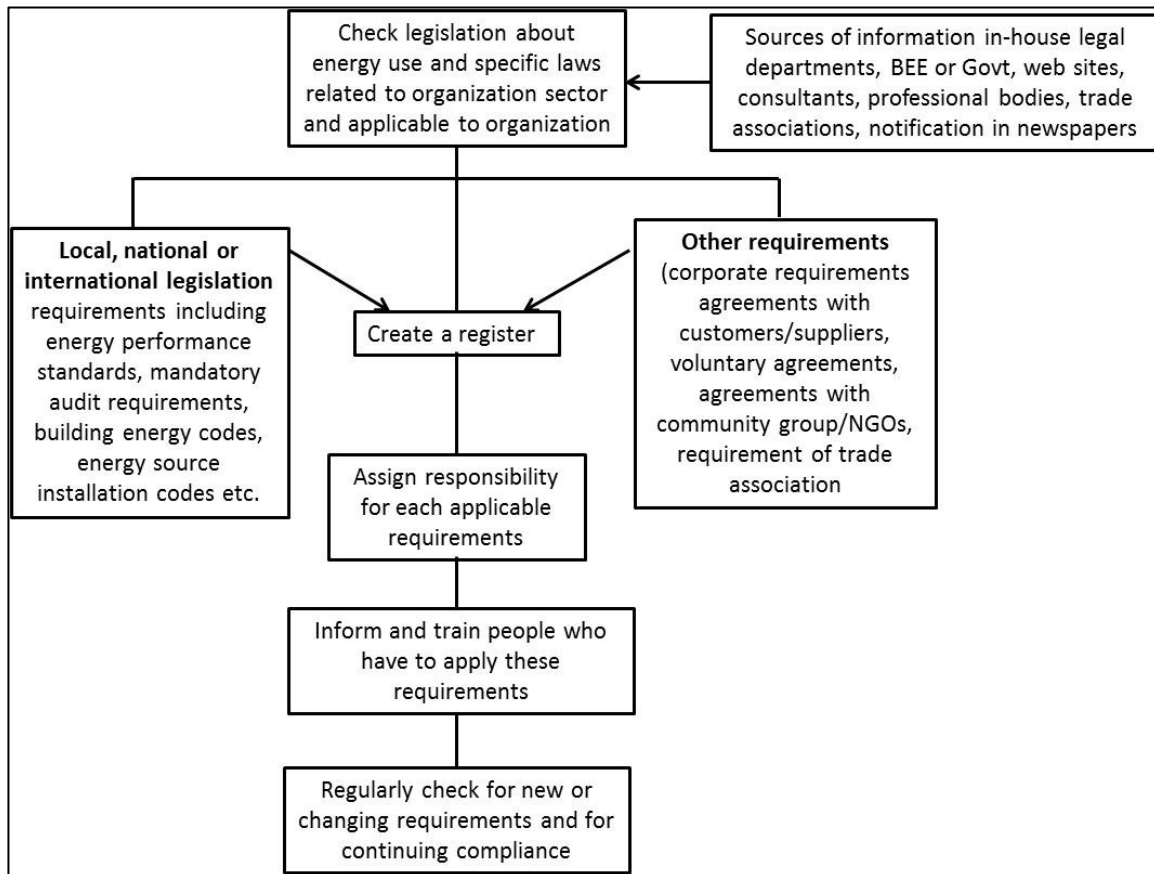
Interested parties (stakeholders) can include Suppliers, Customers, Partners, Employees, Investors, Owners, Bankers/financial bodies, Regulatory bodies, Unions, Competitors, Society, Opposing pressure groups, government, shareholders etc.

Organization is also required to ensure that it has access to the applicable legal requirements and other requirements related to its energy efficiency, energy use and energy consumption; determine how these requirements apply to its energy efficiency, energy use and energy consumption; ensure that these requirements are taken into account and reviewed at defined intervals.

Legal requirements are laws and acts that apply to an organisation's energy use, consumption, and efficiency. These may include Energy Conservation Act, 2001, Perform, Achieve Trade (PAT), Energy Conservation Building Code (ECBC), Boiler Act, Water Pollution Act, Air Pollution Act, Electricity Act, Factory Act etc. as applicable to the organization. Besides these, there may be some regional, national, or international laws that may apply to an organisation.

Other requirements that may apply to the organization include voluntary agreements, corporate agreements/targets, agreements with customers and suppliers, requirements of trade associations, agreements with community groups or NGOs etc.

A list of all applicable legal and other requirements relevant to energy should be developed, and the organisation needs to decide how these requirements apply to its activities and how compliance can be effectively ensured as shown in Figure 5.3. The entire process of identification and evaluation should be clear and include a description of how compliance is assessed. Best method would be to establish the responsibility for identification, compliance and monitoring and reviewing compliance.



**Figure 5.3: Addressing Legal and Other Requirements**

The ISO 50001 standard requires organization to review legal requirements and other requirements at defined intervals. However, in addition to this interval, there might be some occasions when organization need to review these requirements and such occasions could be changes to applicable legal and other requirements as well as changes in organization's operations that might affect applicability of these requirements. *For example, under PAT, a textile mill will become a designated consumer as soon as its total energy consumption exceeds 3000 MTOE per annum and this has to be checked by the textile mill from time to time. Similarly, more and more sectors are being added under PAT jurisdiction every three years with beginning of new PAT cycle.*

#### 4.3 Determining the scope of energy management system

The organization is required to determine and document the scope and boundaries to be covered in its EnMS to establish its scope. While determining the EnMS scope, the

organization is required to consider the external and internal issues referred to in 4.1 as well as the requirements referred to in 4.2.

Scope covers facilities, operations, products and activities whereas boundaries cover parts of the site on which it has the authority to control its energy efficiency, energy use and energy consumption. In the new version, the organization cannot exclude an energy type within the scope and boundaries of EnMS.

#### **4.4 Energy management system**

The organization is required to establish, implement, maintain and continually improve an EnMS, including the processes needed and their interactions, and continually improve energy performance. The processes needed will depend on the size of organization and its type of activities, processes, products and services; the complexity of processes and their interactions; and competence of personnel.

### **5 Leadership**

#### **5.1 Leadership and commitment**

New version of the standard has put stronger emphasis on the role of top management wherein it is required to demonstrate its leadership and commitment with respect to continual improvement of its energy performance and effectiveness of the EnMS by way of fulfilling a number of responsibilities mentioned therein. Top management can delegate some of those responsibilities but the overall accountability will still lie with top management.

Top management support is a prerequisite to the successful implementation of an energy management system. Top management should provide the necessary resources such as time, manpower, money, materials for effective implementation of the EnMS. Energy-saving opportunities are to be given same priority as part of normal daily activities and decision-making of the organisation. Top management commitment must be communicated and made visible to the entire organisation through employee involvement activities such as empowerment, motivation, recognition, training, rewards and participation.

#### **5.2 Energy Policy**

Energy policy is a high-level statement conveying the overall intentions and directions of the organisation aligned with its long-term goals. It is established and documented by the top management. It shows top management commitment and support to energy performance improvement and serves as a guideline for setting targets, making decisions, and providing framework for actions.

The energy policy should clearly state organisation's energy priorities. ISO 50001 requires that the energy policy must demonstrate the commitments at least for (i) continual improvement of energy performance and the EnMS, (ii) availability of information and

necessary resources to achieve its objectives and energy targets, and (iii) satisfy applicable legal and other requirements related to energy efficiency, energy use and energy consumption.

An energy policy is the foundation for developing an organization's EnMS through all phases of planning, implementation, operation, performance evaluation and improvement. It provides a framework for setting and reviewing objectives and targets. Policy document should be a brief statement so that members of the organization can readily understand and apply to their work activities. The energy policy dissemination can be used as a means to manage organizational behaviour. The policy is required to be well communicated within the organization, be available to interested parties and be periodically reviewed and updated as necessary. Every word used in energy policy is important and therefore, organization should avoid overcommitting and inclusion of those points in the energy policy which it cannot meet. A model energy policy is shown in Figure 5.4.

<b>Model Energy Policy</b>	
<p>As an energy intense manufacturer of specialty glass, ABC Company strives to reduce its energy consumption and costs and promote the long-term environmental and economic sustainability of its operations. We are committed to:</p> <ul style="list-style-type: none"> <li>– <b>Reduce</b> energy use per unit of production in our manufacturing operations.</li> <li>– <b>Ensure</b> continual improvement in plant energy performance.</li> <li>– <b>Deploy</b> information and resources to achieve energy objectives and targets.</li> <li>– <b>Uphold</b> legal and other requirements regarding energy.</li> <li>– <b>Consider</b> energy performance improvements in design and modification of facilities, equipment, system, and processes</li> <li>– <b>Effectively</b> procure and utilize energy-efficient products and services.</li> </ul>	
<p><b>Managing Director:</b> _____</p>	<p><b>Date:</b> _____</p>

**Figure 5.4: Model Energy Policy**

### **5.3 Organizational roles, responsibilities and authorities**

Top management is required to form an Energy Management Team which will have the responsibility and authority to ensure effective implementation of the EnMS and for delivering energy performance improvement. It is also required to ensure that the responsibilities and authorities for relevant roles are assigned and communicated within the organization.

The team approach takes advantage of the diversity of skills and knowledge of individuals. Good practice is to have a cross-functional teams from all sections of the organizations that

can affect energy performance. This approach provides an effective mechanism to engage different parts of the organization in the planning, implementation, maintenance and improvement of the EnMS as well as of energy performance. Members of the team may change from time to time and should be based on defined roles (designations) rather than named individuals.

For smaller organizations, a single person might be enough, whereas large organizations will require this cross-functional team for effective planning and implementation of EnMS in different parts of the organization. Size of this team will depend on size and nature of the organization and available resources.

## 6 Planning

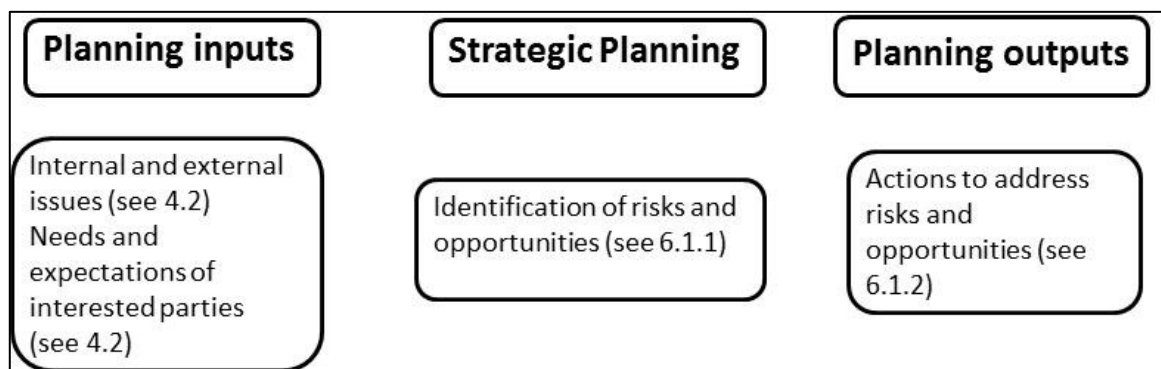
### 6.1 Actions to address risks and responsibilities

**6.1.1** The organization is required to determine the risks and opportunities that need to be addressed to give assurance that the EnMS can achieve its intended outcome(s), including energy performance improvement; prevent or reduce undesired effects; and achieve continual improvement of the EnMS and energy performance.

By identifying risks and opportunities when planning the EnMS, an organization can anticipate potential scenarios and consequences so that undesired effects can be addressed before they occur. Similarly, favourable considerations and circumstances that can offer potential advantages or beneficial outcomes can be identified and pursued.

**6.1.2** Under this clause, the organization is required to plan actions to address these risks and opportunities and how to integrate and implement the actions into its EnMS and energy performance processes as well as evaluate the effectiveness of these actions.

A concept diagram illustrating the strategic planning is shown in Figure 5.5.



**Figure 5.5 Strategic Planning to address risk and responsibilities**

## **6.2 Objectives, energy targets and planning to achieve them**

**6.2.1** The data analysis and other information outputs from Energy Review are used in developing objectives and energy targets. Setting objectives and targets provides the means for transforming policy into action. These are to be established for all relevant functions and levels of the organization.

**6.2.2** Objectives are broader and normally covers whole of the organization/department/section and directly relevant to organization's energy policy. They could be quantifiable as well as qualitative.

Quantifiable objectives have targets for performance improvement (e.g. reduce electricity consumption by 3 % by the end of the year). Qualitative objectives relate to energy behaviour, cultural change etc. It is often possible to provide some quantitative values for qualitative objectives, through surveys or other similar mechanisms.

Similarly, energy targets are consistent with objectives as they emerge from them and have more details. Targets should be SMART (specific, measurable if practical, achievable, relevant and time-based). It can be expressed in terms of the percentage improvement in energy performance or improvement in energy consumption or the EnPI with appropriate baseline period reference.

Factors which need to be considered while establishing and reviewing objectives and energy targets include legal requirements and other requirements, significant energy uses, opportunities to improve energy performance, financial, operational and business conditions, technological options and the views of interested parties.

**6.2.3** Actions which are required to be taken to achieve the targets are known as Action Plans. The energy management action plans are the road map to what is needed to achieve the objectives and energy targets. These typically arise from the energy performance improvement opportunities that were identified and prioritised as part of the energy review.

Top management is supposed to provide required resources for successful implementation of action plans. Action plans are required to show allocation of responsibility, resources required, time frame for completion, how to verify the improvement in energy performance (measurement method and other relevant details) and how to verify the result etc. An example showing consistency relationship between Energy Policy, Objective, Target and Action plan is shown in Table 5.1.



**Table 5.1: Consistency Relationship between Policy, Objective, Target and Action Plan**

Relevant portion in Energy Policy	Energy Objective	Energy Target	Action Plan					
			Details of action plan on what is to be done	By whom	Method of verification for energy performance improvement	Resources required	Time frame for completion	Method of verifying results
We shall improve our energy performance continually	Reduction in specific electrical Energy Consumption by end of July, 2019	Reduction of 10% in units consumed per MT of production as compared to 2017-18 by end of July, 2019	(i) All remaining inefficient lighting to be replaced with LED lighting	A.M. (Purchase) to procure and Maintenance In-charge to install	Power drawn by each type of existing lighting and of corresponding replacement	Finance for procuring all remaining inefficient lighting and manpower for doing it	Dec, 2018	Electrical submeter readings installed on lighting feeder & compressed air section and electricity bill stating total energy consumption for the month
			(ii) Replace pneumatic packing machines with mechanical packing machines	A.M. (Purchase) to procure and Maintenance In-charge to install and commission	No compressed air is required by packaging machines	Finance and manpower for Tendering, procuring, installation and commissioning of mechanical machines	July, 2019	
			(iii) Set screw air compressor pressure settings at optimum level to save power	Maintenance In-charge	Power drawn by each compressor during load before and after resetting of pressures	Manpower and skill for resetting the pressures for load and unload on all air compressors	Dec, 2018	
			(iv) Install VFDs at identified equipment having variable loads	A.M. (Purchase) to procure and Maintenance In-charge to install	Air compressor does not run in unload mode	Finance and manpower for Tendering, procuring, installation and commissioning of VFDs	April, 2019	

### 6.3 Energy review

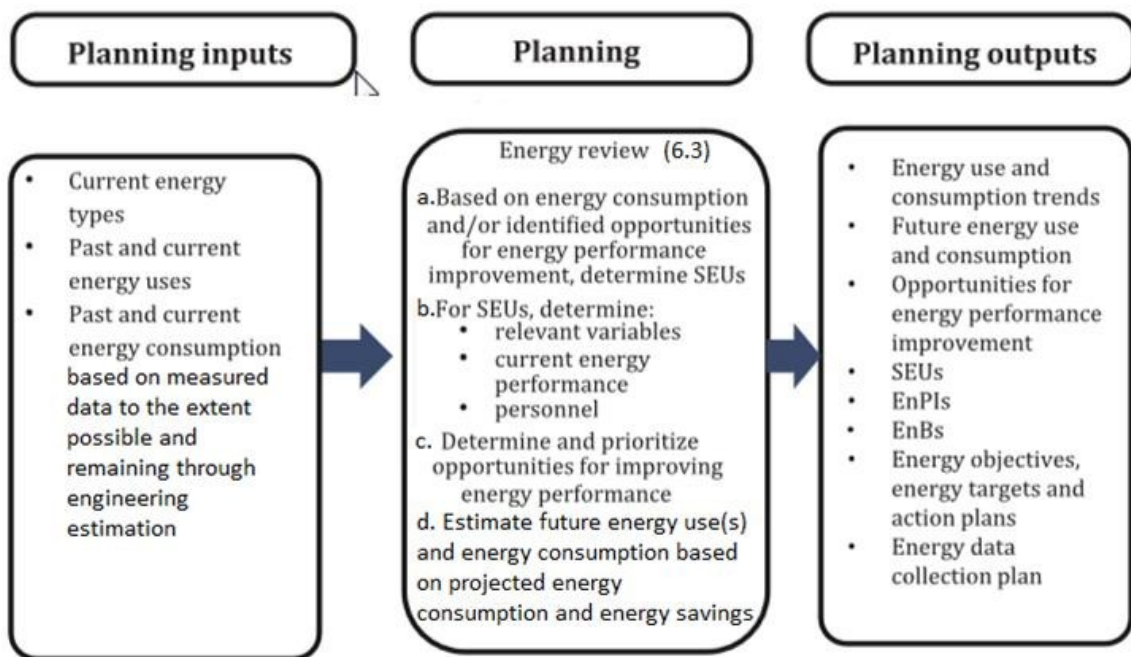
To improve energy performance, it is necessary to understand how, why, and where energy is being consumed and to identify where opportunities to improve exist.

The energy review is the analytical part of tactical energy planning process. The purpose of the energy review is to obtain an overall picture of an organisation's energy use, patterns of use of each energy source, consumption trends, energy performance, variables affecting energy consumption (say production), opportunities for savings, and the resources required in terms of manpower, time and investments.

One of the important activities of energy review is to identify significant energy uses (SEUs) so that areas using more energy and/or having more potential for energy saving and/or both can be focused and planned accordingly. SEUs can be defined depending on the needs of the organization, such as by facility (e.g. warehouse, factory, office), by process or system (e.g. lighting, steam, transport, electrolysis, motor-driven) or equipment (e.g. motor, boiler). Once identified, the management and control of SEUs are an integral part of the EnMS.

Energy review is required to be updated at defined interval (at least annually) or when there

are major changes in the energy scenario of the organization. The various steps involved in carrying out energy review are illustrated in Figure 5.6.



**Figure 5.6: Energy Review**

#### Steps in conducting Energy Review

1. Collect data on energy use for past 12/24 months
2. Analyse past and current energy use with relevant drivers (e.g. production)
3. Identify and challenge each SEUs (based on energy use and consumption)  
*(If measured data on energy consumption are not available, then, estimate using actual power drawn and hours of operation)*
4. Identify variables affecting energy consumption and effect on SEUs
5. Determine current performance and baseline of identified SEUs
6. Identify and prioritize opportunities for improvement
7. Estimate future energy used based on projected production and expected energy saving which may result from implementation of energy conservation measures.
8. Agree objectives, energy targets and action plans.

#### 6.4 Energy Performance Indicators

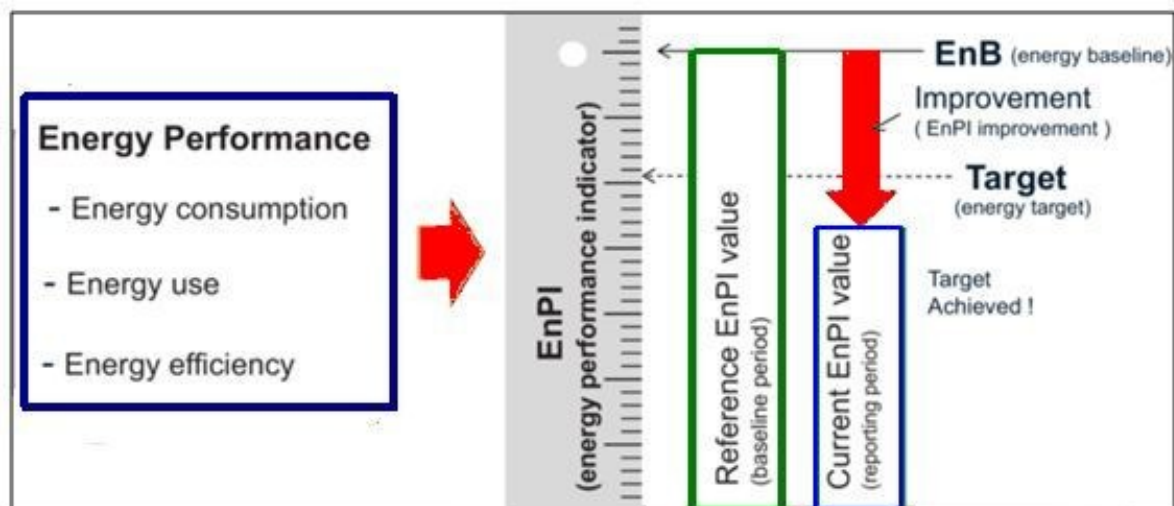
Energy review provides the information and data needed to establish EnPIs. EnPI is a “ruler” that is used to compare energy performance before (reference EnPI value) and after (resultant or current EnPI value) after implementation of action plans. The difference between the reference value and the resultant value is a measure of a change in energy performance.

EnPI helps turn energy data into useful information for top management. Types and examples of EnPIs are as follows:

- Simple energy consumption in kWh or kCal (in total or breakdown by energy use or by facility or by equipment)
- Simple ratios like energy consumption per time, or per unit of floor area or per unit of production
- Statistical model including linear or non-linear regression

The methodology the organization is going to adopt on this matter and updating of EnPIs needs to be maintained as documented information. EnPI value(s) shall be reviewed and compared to their respective baseline value(s) (EnB) to assess energy performance and improvements, and need to be retained as documented information.

The Figure 5.7 illustrates the simple case where direct measurement of energy consumption is used as EnPI and the energy performance is compared between the baseline period and the reporting period. It also shows whether target (in case it was set) has been achieved or not.



**Figure 5.7: Energy Performance Indicator**

With passage of time and maturity of EnMS, there should be increase in the number of EnPIs through in-depth penetration (from whole organization level to facility to process/system-wise to individual equipment-wise).

## 6.5 Energy baseline

One of the main requirements of the ISO 50001 standard is to have continual improvement in energy performance of the organization, and to find out improvement, one has to have some base to compare with. This is what is known as “Energy Baseline” which is defined as the quantitative reference or references providing a basis of comparison of energy

performance. Energy Review provides the information and data needed to establish the energy baseline.

The energy baseline is the reference for measuring energy performance over time. The type of energy baseline will depend on specific purpose of the Energy Performance Indicator (EnPI) and can be established at the facility, system, process, or equipment level. The energy baseline can be expressed as a mathematical relationship of energy performance as a function of relevant variables; an engineering model; a simple ratio; or simple consumption data (if there are no relevant variables).

Baseline is always pertaining to a period which is known as baseline period. This period should be representative of one complete cycle of the variations in the organizational operation like seasonal fluctuations in production in case of industries; occupancy in case of hotels; temperature & humidity in case of air conditioning in buildings etc. In all such cases, the baseline could be considered as one year. When determining energy performance improvement, the data needs to represent the same period as the baseline.

In almost all the cases, energy consumption is affected by relevant variables and these variables will be different in baseline period and the reporting period for which improvement is to be determined. Where the organization has data indicating that relevant variables significantly affect energy performance, the organization shall carry out *normalization* of the EnPI value(s) and corresponding EnB(s). Depending on the nature of the activities, normalization can be a simple adjustment, or a more complex procedure.

In order to do “apple to apple comparison” and to correctly assess the improvement made in energy performance, some adjustments in baseline may be required in certain cases. These cases could be one or more of the followings:

- a) where current EnPIs, the organizational boundaries and the energy baselines are no longer appropriate and effective to reflect organizations energy use and consumption, or
- b) there have been major changes to the process, operational patterns, or energy systems, (for example steam turbine is installed to generate electricity between baseline period and reporting period which will change the entire energy including fuel scenario of the organization) or
- c) according to a predetermined method like ‘normalization’ in PAT, where adjustment is made in the reporting period energy consumption due to changes in relevant variables or Static factors.

## **6.6 Planning for collection of energy data**

Data are critically important in monitoring and analyzing key characteristics. Planning for which data to collect, how to collect, and how often to collect, form Energy Data Collection Plan. This plan will depend upon the size and complexity of organization, its resources and its monitoring and measurement equipment. The plan needs to be reviewed at defined

intervals and updated as appropriate. The measuring equipment used for monitoring energy consumption and performance for operational decisions should be accurate, consistent and periodically calibrated.

## **7 Support**

### **7.1 Resources**

The organization is required to determine and provide the resources needed for the establishment, implementation which can include human resources, financial resources, specialized skills, technology, data collection infrastructure etc.

### **7.2 Competence**

This is the responsibility of organization to ensure that all people working under its control and which can affect its energy performance are competent on the basis of appropriate education, training, skills and experience and takes necessary action like the provision of training to, the mentoring of, or the reassignment of currently employed persons; or the hiring or contracting of competent persons etc to acquire the necessary competence and evaluate the effectiveness of action taken as well as retain appropriate documented information as evidence of competence.

Training is one of the many methods for achieving competency. EnMS team members should be encouraged to continually develop, maintain and improve their knowledge, skills and expertise. Organization can also consider certification course like BEE's course for Certified Energy Auditor/Manager or Lead Auditor course for ISO 50001 etc to improve their competence level.

Competence requirements need to be appropriate to the function, level and role of persons (including top management) doing work, which affects energy performance and the EnMS. Competence requirements are determined by the organization.

### **7.3 Awareness**

Organization needs to ensure that every one working for it (regular employees, contract workers, security staff, helpers etc.) is aware of importance of conformity to energy policy and EnMS requirements; his/her roles, responsibilities and authorities in achieving the requirements of EnMS; benefits of improved energy performance as well as impact of their activities in achieving the same etc. Table 5.2 shows a sample training plan.

**Table 5.2: Sample Training Plan**

<b>Type of Training</b>	<b>Participants</b>
EnMS Awareness	All who are working under the control of organization
EnMS Implementation Training	Middle Management /Energy Management Team
EnMS Internal Auditor (IA) Training	Energy Management Team/Anyone interested in conducting Internal Audit (However, their competency needs to be ensured before they are allowed to conduct IA)
Training related to control of SEU	All personnel related to SEUs

## **7.4 Communication**

Good internal and external communication is essential to managing change. It keeps personnel informed of energy management activities, incentives, and successes, which strengthens commitment and participation. Multiple channels of communication, whether verbal or nonverbal can be used such as meetings, videos, briefings, e-mails, posters, memos, circulars etc. The organization is required to determine the internal and external communications relevant to the EnMS, including on what it will communicate; when to communicate; with whom to communicate, how to communicate and who communicates.

Organization is required to implement a suggestion scheme with incentives and rewards for good suggestions that can be implemented to stimulate interest and participation of all those who are working under the control of the organization.

## **7.5 Documented information**

### **7.5.1 General**

Documented information is defined as the information required to be controlled and maintained by an organization and the medium on which it is contained. It can be in any format and media, and from any source. Also, it can refer to the management system, including related processes; information created in order for the organization to operate (documentation); and evidence of results achieved. Thus, in the new ISO version, the term *documented information* includes *document(s)*, and *records*.

Documentation enables communication of intent and consistency of action. Its use contributes to achievement of conformity to requirements of the standard and provides objective evidence thereof. However, generation of documentation should not be an end in itself, but it should be a value-adding activity.

A certain amount of documented information is required in the EnMS. Minimum (mandatory documented information) as required by the standard under various clauses (clause numbers are mentioned in the bracket) are as follows:

- Scope and Boundaries of the EnMS (4.3);
- Energy Policy (5.2);
- Objective and Targets (6.2.2);
- Action Plans for achieving energy objectives and targets (6.2.3);
- Methodology and criteria used to develop the energy review (6.3);
- Energy review results (6.3);
- Method for determining and updating EnPIs (6.4);
- EnPIs Values (6.4);
- EnB(s), relevant variable data and modifications to EnB(s) (6.5);
- Data to be collected and retained (6.6);
- Details on measurement, monitoring and other means of establishing accuracy and repeatability (6.6);
- Evidence of competence (7.2);
- External origin (7.5.3);
- Operational planning and control (8.1);
- Design activities (8.2);
- Results of the investigation and response to significant deviation (9.1.1);
- Results from monitoring and measurements (9.1.1);
- Results of the evaluation of compliance and any action taken (9.1.2);
- Evidence of the implementation of the audit programs and the audit results (9.2.2);
- Evidence of the results of management reviews (9.3.4); and
- Nature of nonconformities and subsequent action taken as well as on results of any corrective action (10.1).

### **7.5.2 Creating and Updating**

This clause required organizations to take appropriate action while creating and updating documented information with respect to their identification and description (e.g. a title, date, author or reference number); format (e.g. language, software version, graphics) and media (e.g. paper, electronic) as well as review and approval for suitability and adequacy.

### **7.5.3 Control of documented information**

There is no mandatory procedure that needs to be developed as documented information as per the standard. However, organization can still develop certain procedures as documented information for the convenience of all, especially if ISO management systems are new to the organization. Procedures which can be developed by organization in such a situation can include procedure on Documented Information Control, Internal Audit, Management Review, Nonconformity and Corrective Action, Communication, Identification of Competency, Skill & Training, and Significant Deviation.

Correct identification of the EnMS documents is crucial to ensure that the most up-to-date documents are in use, that they can be easily located, and that obsolete documents are removed from the points of use. Documented information required by the EnMS and by this document shall be controlled to ensure that it is available and suitable for use, where and when it is needed; is adequately protected (e.g. from loss of confidentiality, improper use, loss of integrity).

Any documented information, once developed for the EnMS (including technical documents wherever appropriate) as well as external documents which have been generated outside of the organization, need to be controlled. Some examples of documents of external origin are laws/acts like Energy Conservation Act, 2001; ECBC 2007; Electricity Act, 2003; various standards being used by organization including ISO 50001, important technical documents including equipment manuals prepared by OEMs etc.

## **8. Operation**

### **8.1 Operational planning & control**

This involves examination of how significant energy uses are operated and maintained in comparison with energy-efficient practices. Best practices or criteria for operation and maintenance are developed, ensured that these practices are routinely followed, people responsible for following these practices are well communicated about these, and keeping documented information to the extent necessary to have confidence that the processes have been carried out as planned.

Under this clause, the organization is required to control planned changes and review the consequences of unintended changes, taking actions to mitigate any adverse effects, as necessary. The organization is also required to ensure that outsourced SEUs or processes related to SEUs are controlled.

Although not mandatory, it is a good practice to have documented information on operation and maintenance practices related to energy. These include work instructions, standard operating procedures (SOPs), work flow diagrams etc.

### **8.2 Design**

The design activity associated with energy-saving and operation control presents one of the best opportunities to improve energy performance of new facilities, extensions to existing facilities, new or modified production process, upgrades, refurbishment, change of use and design. While doing so, organization should consider improved technologies, alternative energy such as renewables or less polluting types of energy options, best available energy efficient techniques, practices and emerging trends.

It is much better to design and implement these projects properly the first time round rather than to carry out upgrades or retrofits later. The costs of incorporating energy efficiency



measures during the design stages are much lower and the benefits of doing so are greater than implementing as changes later during the operation stage. This approach can avoid frequent barriers to appropriate energy performances such as oversized equipment, over specified systems, and the use of inefficient technologies. Where applicable, the results of the energy performance consideration shall be incorporated into specification, design and procurement activities.

It is possible that equipment and systems may operate at partial or variable load for significant periods of time and therefore, it should be considered during the design, procurement and commissioning phases of the project.

### **8.3 Procurement**

Procurement is an opportunity to improve energy performance through the use of more efficient products and services. It is also an opportunity to work with the supply chain and influence its energy behaviour.

Procurement policy of the organization should always consider energy implications while purchasing energy services, products, equipment and even purchase of energy itself. Also, while purchasing these, one should consider all costs for their expected life cycle. These costs include capital cost including taxes and duties, installation and commissioning cost, energy cost, maintenance cost, lubricant cost, operating manpower cost, disposal cost etc.

This clause of the standard calls organization to establish and implement the criteria for assessing energy use, consumption and efficiency over planned or expected operating lifetime when procuring energy using products, equipment and services which are expected to have a significant impact on the organization's energy performance. This can include life cycle costs as mentioned above; expected impact on the overall system energy performance (e.g. the energy efficiency of a pumping system at the planned system operating conditions); performance at part load and under fluctuating loads; energy efficiency rating such as BEE labelling program; certification from reputed agencies or from other third parties. For example, a Five Star A.C. or inverter air conditioner will cost more compared to lower star A.C. but energy savings over time will exceed the additional buying cost due to higher efficiency of Five Star or inverter AC as compared to lower star air conditioners.

Even while purchasing energy, organization should consider the opportunities for reducing cost in purchasing electricity and fuels. Factors which can be considered while evaluating purchase of energy should include quantity (to check for bulk discounts for more quantity or penalty for less quantity), quality (voltage fluctuation, harmonic quality etc), price or rates, contract period, reliability, flexibility etc.

Examples of Energy Service providers are energy consultants, energy service companies (ESCOs), energy service providers, energy auditors, energy related trainers etc. Energy services can include annual maintenance services (AMC) and contracts; equipment and technology advice; project design, construction and commissioning; vehicle and transport services and energy or utility suppliers.

Many times, energy performance of an equipment or system is adversely affected due to fact that the organization had not defined and documented energy purchasing specifications while placing the purchase order and hence, wherever applicable, the organization shall define and communicate specifications for ensuring the energy performance of procured equipment and services as well as for the purchase of energy.

## **9. Performance evaluation**

### **9.1 Monitoring, measurement, analysis and evaluation of energy performance and the EnMS**

#### **9.1.1 General**

There are a number of key characteristics that an organisation should monitor, measure and analyse to be aware of its energy performance at regular intervals. To know whether performance is improving as planned, organisation needs to monitor minimum of the key characteristics mentioned in the standard. Organization is also required to determine the methods for monitoring, measurement, analysis and evaluation, as applicable, to ensure valid results; when the monitoring and measurement shall be performed; and when the results from monitoring and measurement shall be analysed and evaluated.

The organization is supposed to evaluate its energy performance and the effectiveness of the EnMS as well as improvement in energy performance by comparing EnPI value(s) against the corresponding energy baselines.

The organization is also required to investigate and take appropriate actions to significant deviations in energy performance which could be on negative side i.e. adverse, or positive side. It is important to investigate deviations on the positive side also so as to ensure their repetition every time.

#### **9.1.2 Evaluation of Compliance with legal requirements and other requirements**

The organization should determine if processes for evaluating compliance with legal and other requirements (which have already been identified and planned under clause 4.2 of the standard) are in place and whether they can be adapted to address the needs of the EnMS. This process is supposed to be carried out at planned frequency and documented information are to be retained.

## **9.2 Internal audit**

**9.2.1** An internal audit of an EnMS is an objective, systematic review of all or part of an organization's EnMS which is carried out at planned intervals. It must be remembered that internal audit of EnMS is a 'fact finding' exercise and not a 'fault finding' exercise and therefore, auditor should not look out for only finding faults. The facts which need to be found out through Internal Audit are whether the EnMS improves energy performance; conforms to the organization's own requirements for its EnMS as well as to its energy policy, objectives

and energy targets established by the organization, the requirements of the ISO 50001 standard and is effectively implemented and maintained. Of course, during this fact-finding exercise, auditor may come across certain non-conformities which are required to be highlighted in the internal audit reporting.

During an internal audit, the auditors' interview relevant personnel, observe operational activities, review documents, and examine records and data.

**9.2.2** Under this clause, organization is required to plan, establish, implement and maintain (an) audit programme(s) as per the details mentioned in the standard.

Internal audit can be carried out more frequently for areas (i) that influence energy performance substantially, (ii) where important nonconformities (NCs) have been identified in previous audits, (iii) that have experienced important changes and (iv) areas where important changes are being planned. Similarly, EnMS internal audits can be conducted less frequently for those areas that do not significantly impact energy performance or for processes that have fewer Nonconformities from previous audits. However, it is suggested that all areas and processes should undergo internal audits annually for at least first two years of EnMS implementation.

### **9.3 Management review**

**9.3.1** This is the key responsibility of top management focused on ensuring the ongoing suitability, adequacy, effectiveness and alignment with the strategic direction of the organization. Management review highlights the top management on the positive outcomes as well as the weaknesses, in order to provide effective recommendations for improvements.

Management review is conducted at planned frequency, which should be at least once a year, within which corrective action can be taken and appropriate systems adjustments can be made. All records pertaining to management review meetings are required to be maintained.

**9.3.2** Minimum Agenda for the management review meeting include the following:

- Status regarding action from previous management review,
- Changes in internal and external issues and associated risks opportunities relevant to EnMS,
- Internal as well as external audit results,
- Existing energy policy appropriateness in the present circumstances,
- Review of the compliance of legal and other requirements,
- Opportunities for continual improvement,
- Monitoring and measurement results,
- Status of nonconformities and corrective actions etc.

**9.3.3** Management review is also supposed to review the extent to which objectives and

energy targets have been met; energy performance and energy performance improvement based on monitoring and measurement results including the EnPI(s) and status of the action plans.

**9.3.4** It is subsequently the task of top management to take decision related to continual improvement opportunities and need for changes in the EnMS which will indicate the organization's energy performance in complete and best possible manner, how improvement in energy performance is progressing, any changes in the energy policy, EnPIs, EnB(s), objectives, targets and action plans, allocation of resources, the improvement of competence, awareness and communication etc.

## **10 Improvement**

### **10.1 Nonconformity and corrective action**

Nonfulfillment of a requirement is a Nonconformity. This requirement could be of ISO 50001 standard of the EnMS which organization has prepared, or of its operation control etc. In simple words any deviation from specified norms is Nonconformity.

When nonconformity is detected, the first step is to take appropriate action to resolve the immediate situation and it is known as correction. For example, In a compressed air system, reduction in air pressure to a level affecting the plant operation due to dirty filter in an air compressor is a nonconformity and cleaning or replacing the filter which will restore the correct air pressure is the *correction*.

However, taking correction may not be enough and nonconformity may reoccur until and unless, investigation is carried out to find out its root cause and then, action is taken to eliminate the root cause of the problem. This is known as the *corrective action*. In other words, action taken to prevent reoccurrence of a detected nonconformity is corrective action. In the above example of compressed air, corrective action would be to determine why filter got dirty and to address the root cause to prevent its reoccurrence. For example, filter might have become dirty because of its location in a dusty room and relocating the compressor in a cleaner room or outside the room will be the *corrective action*.

Taking correction and corrective action should not be confined to internal or external audits only as normally perceived and carried out. Several other sources like results of evaluations of compliance reviews, failure to reach specified targets in monitoring and measurement processes, failure to comply with operational control procedures, repeated significant deviations, routine inspection of the plant etc should also be considered for raising non-conformities. In other words, any activity not happening as per norms in day to day activity of the organization is also nonconformity and hence, a Nonconformity can be raised on it calling for correction and corrective action to take place.

Addressing NCs should be seen as a part of continual improvement process and these give the opportunities to an organization for making improvement. Corrective actions are so

important for the organization that their status is reviewed by top management in every Management Review Meeting.

## 10.2 Continual improvement

As committed in the energy policy, the organization is required to continually improve the suitability, adequacy and effectiveness of the EnMS and also continually improve its energy performance. Demonstrating continual energy performance improvement across the scope and within the boundaries of the EnMS does not mean all EnPI values improve. Some EnPI values improve, and others do not; but across the scope of the EnMS, the organization demonstrates energy performance improvement.

### Summary

From time to time, organization needs to review its entire EnMS journey as to where it wanted to be, what was the situation, what was planned, what needed to be done, whether it has reached there and ultimately what next to improve continually as shown in Figure 5.8.

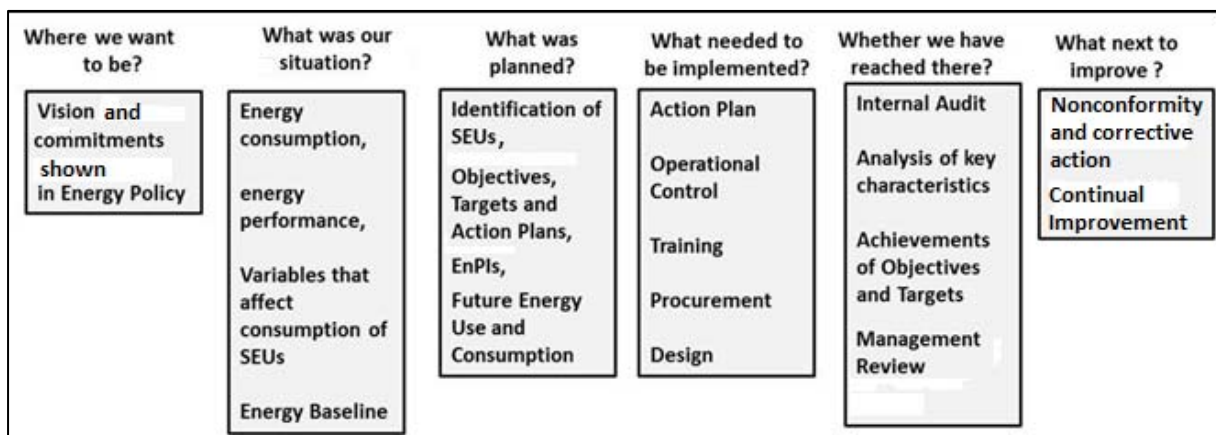


Figure 5.8: EnMS Journey Review

## **6. MEASUREMENT AND VERIFICATION OF ENERGY PERFORMANCE OF ORGANIZATION**

### **6.1 Introduction**

When facility owners/managers invest in energy efficiency projects, they would like to know how much they have saved, how much they will save, and how long the savings will last. Energy savings cannot be measured directly by meters or instruments, since they represent the absence of energy use. Instead, energy savings are determined by comparing measured energy use before and after implementation of an energy saving project with appropriate adjustments for changes in conditions.

Actual energy use can be measured directly before the retrofit (pre-retrofit measurements) and then after the retrofit (post-retrofit measurements). A number of factors, such as weather, occupancy and production levels, influence measured variation of energy use over time, irrespective of whether an Energy Efficiency Measure (EEM) has or has not been implemented. The changes between pre-retrofit and post-retrofit measurements can be declared as the energy savings caused by the EEM. The Measurement and Verification (M&V) is the process of using measurements to reliably determine actual savings achieved within an individual facility by an energy efficiency program.

When there is no doubt about the outcome of a project or there is no need to prove results to third party, M&V may not be necessary. However, it is still useful to verify whether the installed equipment is able to produce the expected savings. Verification of the potential to achieve savings involves regular inspection and commissioning of equipment. However, such verification of the potential to generate savings is not a measurement of savings.

M&V can be used for all types of energy, for any size of organization, for entire organisation or part of it, for a process or product by M&V practitioners, energy auditors, regulatory bodies or any other interested bodies for reporting energy performance results.

This chapter covers the general and basic M&V concepts and techniques and participants may refer the mentioned standards, protocols and guidelines for deeper understanding about M&V techniques.

### **6.2 Standards, Protocols and Guidelines**

The International Standards Organization (ISO) released ISO 50001 in 2011 and updated it in 2018 to help organizations reduce energy use and cost. ISO 50001 provides a framework for anyone wanting to adopt energy management best practices. Subsequently, the standards such as 50004, 50006 and 50015 were released to address the requirements for setting up baseline and measuring progress towards successfully implementing 50001.

*ISO 50004 (Energy management systems — Guidance for the implementation, maintenance and improvement of an energy management system) on proper understanding for meeting the requirements of ISO 50001.*

*ISO 50006:2014, Energy management systems -- Measuring energy performance using energy baselines (EnB) and energy performance indicators (EnPI) -- General principles and guidance provides practical guidance on how to meet the requirements of ISO 50001, and thereby help manage their energy performance.*

*ISO 50015:2014, Energy management systems -- Measurement and verification of energy performance of organizations -- General principles and guidance provides a set of principles and guidelines for Measurement and Verification, thereby increasing the credibility of energy performance.*

The standard ISO 50015 does not specify calculation methods to be used; rather it establishes a common understanding of M&V and how M&V could be applied to different calculation methods. Thus, one has to refer to some other guidelines/protocols to learn calculation methods and other technicalities involved.

A wide range of protocols and guidelines are used world over and most important amongst those are: International Performance Measurement and Verification Protocol (IPMVP); ASHRAE Guideline 14-2002 Measurement of Energy and Demand Savings; M&V Guidelines: Measurement and Verification for Federal Energy Projects by FEMP of U.S. Department of Energy; A Best Practice Guide to Measurement and Verification of Energy Savings produced by the Australasian Energy Performance Contracting Association etc. However, most widely used guideline/protocol worldwide by ESCO industry is IPMVP.

### **6.3 Purpose of M&V**

M&V adds value by increasing the acceptability of energy performance and energy performance improvement results. The credibility of results can encourage organisation to improve energy performance even more. M&V techniques can be used by facility owners or energy efficiency project investors for the following purposes:

**Increase Energy Savings.** Accurate determination of energy savings gives facility owners and managers valuable feedback on implemented energy efficiency measures (EEMs). This feedback helps them to adjust EEM design or operations to improve savings, achieve greater persistence of savings over time and lower variability in savings.

**Document Financial Transactions.** For some projects, the energy efficiency savings are the basis for performance-based financial incentives and/or a guarantee in a performance contract. A well-defined and implemented M&V Plan can be the basis for documenting performance for independent verification.

**Enhance Financing for Efficiency Projects.** A good M&V Plan increases the credibility of projections on the outcome of efficiency investments. The project is more likely to be funded if the confidence of investors and sponsors in energy efficiency project is improved.

**Improve Engineering Design and Facility Operations and Maintenance.** A good M&V Plan encourages comprehensive project design by including all M&V costs in the project's economics. It also helps managers identify and reduce maintenance and operating problems and also provides feedback for future project designs.

**Manage Energy Budgets.** Even where savings are not planned, M&V techniques can be used to adjust for changing facility operating conditions in order to set proper budgets and account for budget variances.

## 6.4 M&V Applications

Application of M&V is unique to each project depending upon its need. Some of the important applications are being discussed here:

### 6.4.1 Energy Performance Contracts

Energy Performance Contract is an arrangement that allows organisation to make improvements in energy efficiency without any investment upfront. The energy-performance contractor or ESCO not only takes the responsibility for purchasing and installing the equipment, but also maintenance throughout the contract. The contractor is paid based on the performance of the installed equipment and only after the equipment actually reduces the energy cost.

The ESCO bears the technical and financial risks during the contract period. Once the EEMs are commissioned, the ESCO continues to measure or monitor energy use and costs of the project for the contract term. Actual energy costs are compared with baseline costs to determine total savings and the payments to the ESCO are subject to level of energy savings achieved. The ESCO is usually required to repay shortfall in cost savings, or carry out additional work over the contact period. At the end of the contract period, the full benefit of cost savings is passed on to the facility owner. Without adequate M&V, there is no basis for determining the amount of energy saved.

Typical contract period is between 4–10 years—a relatively long period, but necessary to be able to structure the contract so the guaranteed savings cover the capital repayment and on-going costs to ensure a positive cash flow to the organization.

For industrial energy performance contract, the primary purpose of M&V is to demonstrate short-term performance of a retrofit project. After demonstration, the plant management takes over responsibility for operation, and usually does not seek an ongoing relationship with an ESCO. The M&V Plan becomes part of the energy performance contract terms and defines the measurements and computations to determine payments or demonstrate



compliance with guaranteed level of performance. Where a facility owner or manager does not have the capability to review an M&V Plan or savings report, it may hire a third-party verifier, separate from the energy-performance contractor.

#### 6.4.2 Use of M&V in PAT Scheme

PAT requires specific energy efficiency improvements for the most energy intensive industries. The scheme proposes improvements in energy intensity in each unit. The energy intensity target is mandated for each unit depending upon its current efficiency with more efficient units having lower targets than less efficient units.

The PAT framework has been developed considering the legal requirement under EC Act, 2001, energy performance of designated consumers, specific targets to be achieved, effective monitoring and measurement, and sustenance of the energy savings. The scheme aims at reduction of specific energy consumption, called 'Gate to Gate Specific Energy Consumption (GtG SEC)' by individual designated consumers (DC). Target for reduction has been set for individual DC.

The design intent of the PAT process is to insulate the DC from variability in SEC due to changes in the uncontrollable factors. The baseline conditions are defined so that the impact of uncontrollable variables can be neutralised by application of suitable adjustment factors ('Normalisation' factors in PAT). The normalisation process for each sector has been developed and templates to be filled have built-in provision for all possible variation for each category covered under PAT. **Thus, need to develop and implement a robust M&V protocol for driving the normalisation process has already been achieved and implemented in the documentation required to be filled by DCs.**

With application of M&V in monitoring and verification of energy efficiency programme, achievement of energy savings against reduction target can be credibly verified thereby strengthening monitoring and verification of PAT scheme. For instance, the credibility of ECerts in the PAT programme will depend upon transparent and reliable energy savings achieved.

#### 6.4.3 M&V for Effective ISO 50001 implementation

Organisation implementing ISO 50001 certification will find Measurement part of M&V and data analysis very helpful in meeting some of the specific requirements of the standard.

For example, requirement on baseline talks about 'adjustments' to be made to the baseline(s). There is another requirement on "Monitoring, measurement, analysis and evaluation of energy performance and the EnMS" where organizations have been asked to ensure that the key characteristics of its operations that determine energy performance are monitored, measured and analysed at planned interval which again will require use of M&V concepts. M&V also helps in preparing *Energy Data Collection Plan* which is one of the requirements under ISO 50001. Thus, M&V is helpful in number of ways in meeting ISO 50001 requirements.

The other applications include facility managers wanting to properly account for energy budget variances; organizations/energy users implementing energy conservation measures and wanting to account for savings; Utility designing and implementing effective demand side management; and new building designers seeking recognition for the sustainability of their designs, e.g. LEED or GRIHA ratings.

## 6.5 Fundamental Principles of M&V

The fundamental principles of good M&V practice are described as follows:

**ACCURATE.** M&V reports should be as accurate as the M&V budget will allow. M&V costs should normally be small relative to the monetary value of the savings being evaluated. M&V cost should also be consistent with the financial implications of over- or under-reporting of a project's performance. Accuracy tradeoffs should be accompanied by increased conservativeness in any estimates and judgements.

**COMPLETE.** The reporting of energy savings should consider all effects of a project. M&V activities should use measurements to quantify the significant effects, while estimating all others.

**CONFIDENTIAL.** All the parties involved in performing M&V should ensure that confidentiality is maintained. In case any information necessary to perform M&V cannot be shared with M&V practitioner, it should be mentioned in M&V Plan as it may affect the results.

**CONSERVATIVE.** Where judgements are made about uncertain quantities, M&V procedures should be designed to underestimate savings.

**CONSISTENT.** The reporting of a project's energy effectiveness should be consistent between different types of energy efficiency projects; different energy management professionals for any one project; different periods of time for the same project; and energy efficiency projects and new energy supply projects. 'Consistent' does not mean 'identical,' since it is recognized that any empirically derived report involves judgements which may not be prepared identically by all M&V practitioners.

**IMPARTIAL.** In order to have confidence in reported results, it is essential that all stake holders show impartial approach. Conflict of interest, if any, should be disclosed before starting M&V process or as they arise during the course of M&V implementation.

**RELEVANT.** The determination of savings should measure the performance parameters of concern, or least well known, while other less critical or predictable parameters may be estimated.

**TRANSPARENT & REPRODUCIBLE.** All M&V activities should be clearly and fully disclosed to ensure transparency and reproducibility to which will contribute to confidence in M&V reports.

## 6.6 The M&V Process

The complete M&V process involves the following six steps:

**1. DEVELOP AN M&V PLAN.** The preparation of an M&V Plan is the single most important M&V activity in an energy savings project. It is central to proper savings determination, and is the basis of verification. The first step in the M&V process is the identification of the proposed energy efficiency measures (EEMs), which are typically identified during a detailed energy audit or investment grade audit. In this step the client, ESCO and the M&V agent need to all agree on the EEMs to be considered in the M&V plan and prepare a description of the energy efficiency project, where it will be implemented, how and why. The expected outcome including estimated energy and demand savings should be defined as these will form the basis for M&V planning.

Advance planning ensures that all data needed for savings determination will be available after implementation of the EEM(s) within an acceptable budget. The M&V Plan should be developed while EEMs are being designed in order to include the cost of M&V when deciding project economics; recording baseline data and methodology for savings calculations while baseline conditions are still measurable and before any savings happen and lastly before completing the design of any new metering equipment.

The recommended contents of an M&V plan are listed in Annexure-6-i. Each topic listed therein should be considered in the M&V design, and be reported upon in an M&V plan that is kept available for future reference. This activity may require installation of special meters or other measurement devices to obtain baseline data. Any special meters added should be carefully selected, calibrated, installed and commissioned.

**2. VERIFY EEM INSTALLATION.** After the EEM is installed, inspect the installed equipment and prepare operating procedures to ensure that they conform to the design intent of the EEM.

**3. DATA GATHERING.** Gather energy and operating data from the reporting period, as defined in the M&V plan.

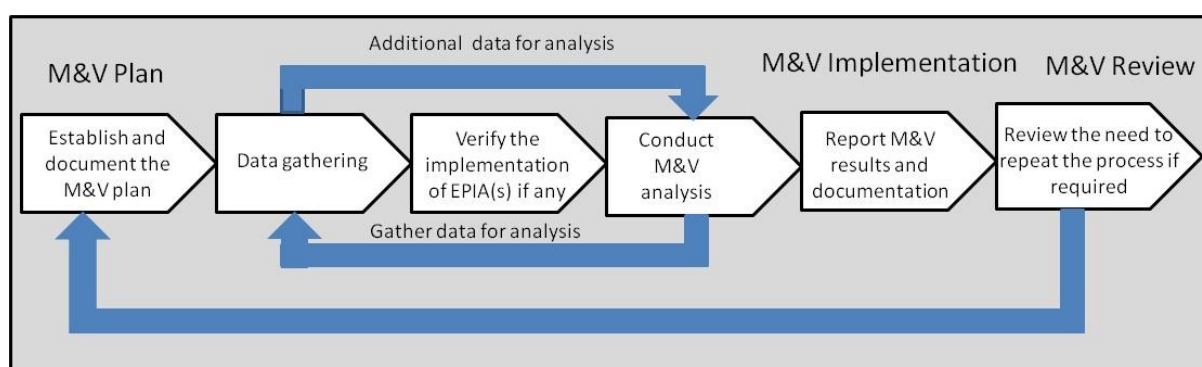
**4. COMPUTE SAVINGS.** Compute savings in energy and monetary units in accordance with the M&V plan.

**5. REPORT SAVINGS.** The final step consists of the preparation of the energy savings report in accordance with the M&V plan. The report describes the savings result, as well as baseline and post-installation data, any adjustments made to the baseline, and the justification. To the extent possible the report should also include comments on the precision

and confidence level of the results. Depending on the M&V plan, the reporting may be one-off or on an ongoing basis over a period of time. Contents to be covered in report are mentioned at Annexure-6-ii of this chapter.

**6. REVIEW THE NEED TO REPEAT PROCESS.** There may be a need to review and repeat a part of or complete M&V process due to some factors such as measurement frequency adopted is not the same as mentioned in M&V plan or measurement frequency other than mentioned in M&V Plan is to be followed; results achieved are not accepted to any or all stakeholders; complete effect of some issues or challenges encountered during M&V process have not been considered etc.

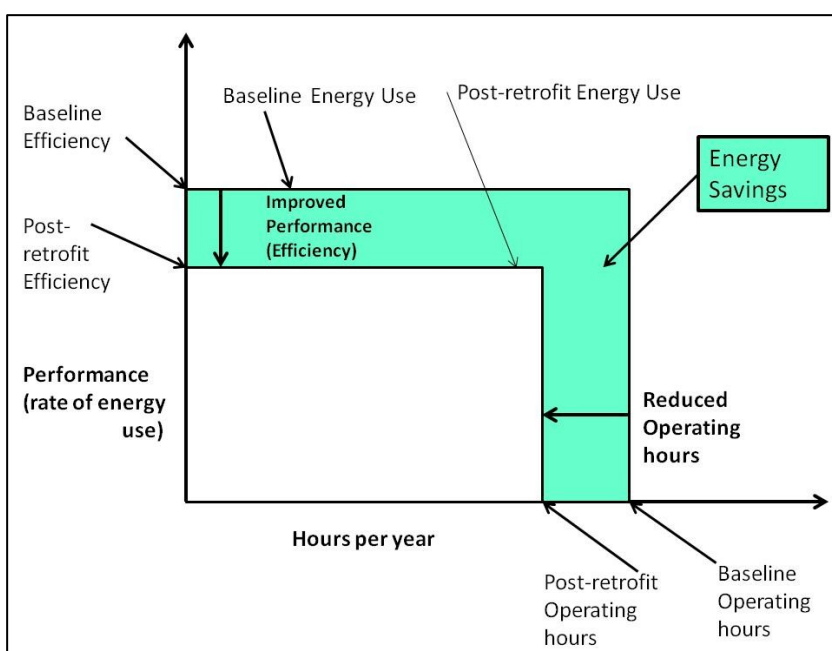
The complete M&V Process can be understood with Figure 6.1:



**Figure 6.1: Steps involved in M&V Process**

## 6.7 Factors driving Energy Savings

There are two fundamental factors that drive energy savings: performance and usage (Figure 6.2). Performance describes how much energy is used for a specific task; usage describes how much of the task is required, such as the number of operating hours during which a piece of equipment operates. For example, in the simple case of lighting, performance is the power required to provide a



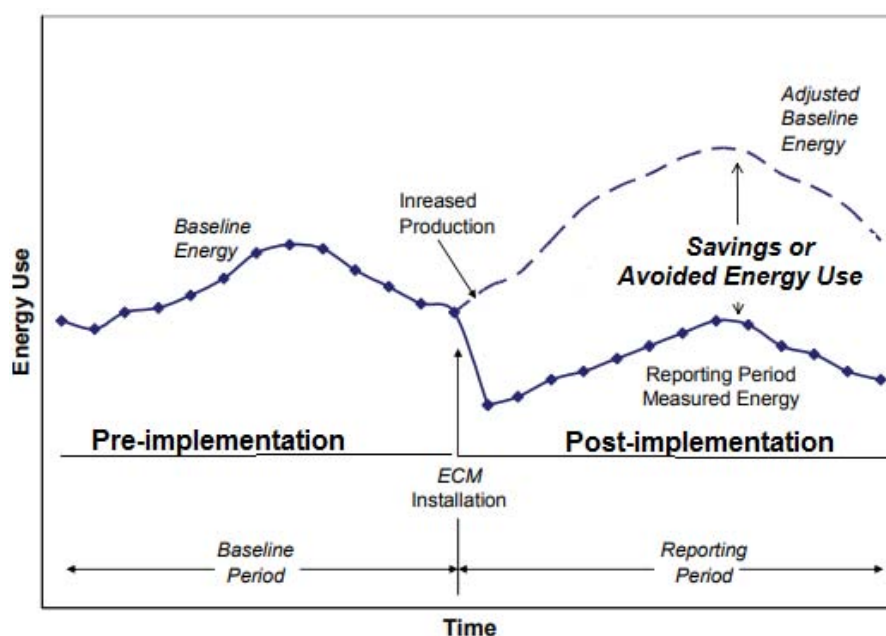
**Figure 6.2: Energy Savings Depend upon Performance and Usage**

specific amount of light, and usage is the operating hours per year. For a chiller (which is a more complex system), performance is defined as the energy required to provide a specific amount of cooling (which varies with load), whereas usage is defined by the cooling load profile and the total amount of cooling required. Both performance and usage are needed to determine savings.

The area of the large box shown in the figure represents the total energy used in the baseline case. Reduction in the rate of energy use (increase in performance) or reductions in usage (decrease in operating hours) lead to reduced total energy use, which is represented by the smaller box. The difference between the two boxes—the shaded area—represents the energy savings.

## 6.8 Measuring Energy Savings and Examples

Energy or demand savings cannot be directly measured, since savings represent the absence of energy use or demand. Instead, savings are determined by comparing measured use or demand before and after implementation of a program, making suitable adjustments for changes in conditions.



**Figure 6.3: Energy Use of Industrial Boiler before and after ECM**

As an example of an energy savings determination process, Figure 6.3 shows the energy usage history of an industrial boiler before and after the addition of an energy efficiency measure (EEM) to recover heat from its flue gases. At about the time of EEM installation, plant production also increased.

To properly document the impact of the EEM (heat recovery), its energy effect must be separated from the energy effect of the increased plant production. The “baseline energy” use pattern before EEM installation was studied to determine the relationship between energy use and production. Following EEM installation, this baseline relationship was used to estimate how much energy the plant would have used each month if there had been no EEM (called the “adjusted baseline energy”). The savings, or ‘avoided energy use’ is the difference between the adjusted baseline energy and the energy that was actually measured during the reporting period.

**Without the adjustment for the change in production, the difference between baseline energy and reporting period energy would have been much lower, under-reporting the effect of the heat recovery.**

It is necessary to segregate the energy effects of a savings program from the effects of other simultaneous changes affecting the energy using systems. The comparison of before and after energy use or demand should be made on a consistent basis, using the following general Equation:

$$\text{SAVINGS} = (\text{Baseline Energy Use} - \text{Post-Installation Energy Use}) \pm \text{Adjustments}$$

#### **Baseline measurement period**

Normally, this period spans a full operating cycle from maximum energy use to minimum so as to represent all operating conditions of a normal operating cycle, unless, it is defined differently for legal requirements—for the first PAT cycle, the baseline period was considered as three years. The baseline period should coincide with the period immediately before implementation of the energy savings measures to provide a proper baseline for measuring the effect of only the energy savings measure.

#### **Reporting measurement period**

The reporting measurement period shall have at least one normal operating cycle of the equipment or facility, in order to fully represent the savings effectiveness in all normal operating modes. The length of any reporting period shall be determined considering the life of the EEM and the likelihood of degradation of originally achieved savings over time. The reporting measurement period may also depend on legal or other compliance requirements.

#### **Adjustments**

The “Adjustments” term in this general equation is used to restate the energy use of the baseline and reporting periods under a common set of conditions. This adjustments term distinguishes proper savings reports from a simple comparison of usage or cost before and after implementation of an EEM. Simple comparisons of utility costs without such adjustments report only cost changes and fail to report the true performance of a project or facility. To properly report savings, adjustments must account for the differences in conditions between the baseline and reporting periods.

The following are two simplified examples of the need to use “adjustments”.

**Lighting Retrofit:** The energy savings guaranteed for a Call Centre lighting retrofit project was based on a weekday two-shift operation. A separate sub-meter had been installed for lighting circuits. Six months after the retrofit implementation, the Call Centre expanded its services and moved to a 7-day three-shift operation.

At first, the annual energy savings calculation, ignoring the increased number of operational hours in the post-retrofit period, did not show any energy savings.

Subsequently, the baseline energy consumption (12-month base year consumption for 5 days/2-shift operation) was adjusted to the increased operational hours (for 7 days/3-shift operation) in the post-retrofit period showed the expected energy savings.

**Additional Hospital Building:** The energy savings for a hospital retrofit project was based on using continuous monthly billing data from the utility meters measuring the entire site consumption. During the second 12-months of the post-retrofit period, a new building became operational. The additional energy consumption from this new building would have negated the achieved energy savings. The consumption measured by a sub-meter installed for the new building was used to adjust the post-retrofit energy measured by the utility meters (which now included the new building's consumption) back to only the buildings within the original measurement boundary for the project.

Savings are commonly computed in the Equation by adjusting baseline energy use to the conditions of the reporting period. Using this form of adjustment, savings can be thought of as “avoided energy (or cost).” This common form of expression of savings is the amount of energy (or rupees) not expended during the reporting period, as a result of the project.

## 6.9 The Four Basic Options or Methods for Conducting M&V

Four basic Options or Methods are available for evaluating avoided energy use. Figure 6.4 illustrates these options. Options A & B are called **retrofit isolation** methods and Options C & D are called **whole-facility** methods and difference between them is where measurement boundaries are drawn. Table 6.1 summarizes applications of different options. The subsequent subsections provide the overview of each method, along with examples of its applications for the energy conservation measures (EEMs).

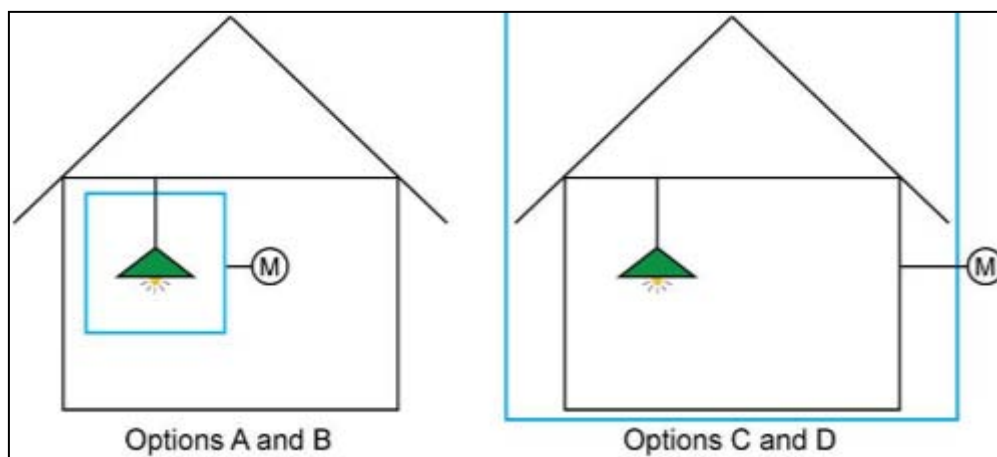


Figure 6.4: Illustrations of M&V Options

**Table 6.1 Four Basic Options or Methods for Evaluating Avoided Energy Use**

Option		Important Features	EEM Examples
A	Retrofit Isolation: Key Parameter Measurement	Possible reduction in measurement cost, but introduces some uncertainty in the estimated saving.	<ul style="list-style-type: none"> <li>• Simple Lighting retrofits</li> <li>• Motor replacement</li> <li>• Steam trap replacement</li> </ul>
B	Retrofit Isolation: All Parameter Measurement	More accurate results due to measurements of all parameters	<ul style="list-style-type: none"> <li>• Complex lighting retrofits</li> <li>• Motor Replacement</li> <li>• Variable Speed Drive</li> <li>• Renewable energy generation</li> </ul>
C	Whole Facility Analysis	Need baseline as well as reporting period data	<ul style="list-style-type: none"> <li>• Whole facility/building retrofits (involving lighting, HVAC and other EEMs)</li> </ul>
D	Whole Facility: Calibrated Simulation	When there is no meter in the baseline, baseline data can be 'manufactured' under controlled circumstances (simulation)	<ul style="list-style-type: none"> <li>• New Building</li> <li>• Building Envelope improvement</li> <li>• Energy management control system</li> <li>• Variable air volume conversion</li> </ul>

### 6.9.1 Measurement Boundary

Savings can be determined for an entire facility or for a portion of it, depending upon the purposes of the reporting.

If the purpose of reporting is to help manage only the equipment affected by the savings program, measurement boundary should be drawn around that equipment and all significant energy requirements of the equipment within the boundary can be determined. This approach is used in the Retrofit Isolation Options.

If the purpose of reporting is to manage total facility energy performance, the meter measuring the supply of energy to the entire facility should be used to assess performance and savings. The measurement boundary in this case involves the entire facility.

Options A and B are used if EEM is about improving the efficiency of operation of end-use equipment, such as a lighting installation, chiller, pump or boiler etc. Options C & D are concerned with the entire facility.

### 6.9.2 Option A – Retrofit Isolation: Key Parameter Measurement

This is the simplest method and involves the lowest cost. When savings measurement is concerned with a single EEM, "isolation" meter is installed to measure the energy use of the system affected by the EEM, separate from the energy use for the rest of the facility. Saving is determined by field measurement of the key performance parameter which defines the energy use of the EEM's affected system and the success of the project.



Meter location (i.e. the measurement boundary) should include as many of the significant energy impacts of the EEM as the M&V budget can allow. The frequency of measurement ranges from short term to continuous, depending on the expected variations in the measured parameter, and the length of the reporting period.

Parameters not selected for field measurement are estimated. Estimations can be based on historical data, manufacturer's specifications, or engineering judgment. Justification for estimating the parameters should be documented.

The savings are verified by engineering calculations using short term or continuous post-retrofit measurements and stipulations. The possible error in savings arising from stipulations rather than measurement is also evaluated and documented.

Energy impacts which are not measured (i.e. which are outside the measurement boundary) are called interactive effects and should be estimated.

**Example:** The type of lamp fitting in a lighting installation is changed to more efficient type, while maintaining the same quality of light. The energy used by the old and new lighting system can be measured, and savings can be calculated. The number of hours of use is stipulated, if the lights are controlled manually.

$$\text{Savings kWh} = (\text{Old energy use kW} - \text{New energy use kW}) \\ \times \text{Stipulated hours of operation}$$

In the above case, measurement boundary should include power to the light. However, lowering lighting energy may also lower any cooling (air-conditioning) requirements. Such cooling energy attributed to lights cannot be easily measured. They are interactive effects which may have to be estimated, rather than included within the measurement boundary.

### 6.9.3 Option B – Retrofit Isolation: All Parameter Measurement

Option B is similar to Option A in that it draws a measurement boundary around the EEM, smaller than the entire facility. However, it differs from Option A in requiring measurement of **all EEM parameters** used to compute energy, or measurement of energy use itself.

Savings are determined by field measurement of the energy use of the EEM-affected system. Measurement frequency ranges from short term to continuous, depending on the expected variations in the savings and the length of the reporting period.

Savings are calculated by short term or continuous measurements of baseline and reporting period energy, and/or engineering computations using measurements of proxies of energy use.

In the earlier example given in 6.9.2, if automatic lighting control is included in the EEM, operating hours cannot be stipulated. Savings from the lighting retrofit project should be reported by measuring both operating periods and load change.

Operating periods might be measured by lighting loggers inserted in randomly selected fixtures to record. The lighting system energy use is then computed by multiplying the measured load change by the measured operating periods for both the baseline and reporting periods.

Alternatively, electricity consumption (kWh) with electrical energy meter(s) before and after ECM at lighting panel can be measured for both the baseline and reporting periods.

$$\text{Savings kWh} = \text{Old energy use kWh} - \text{New energy use kWh}$$

#### 6.9.4 Option C – Whole Facility

This is used for a single major EEM or multiple EEMs within a whole facility or building. Energy use is measured by utility meters for at least 12 months of the base year and continuously throughout the post-retrofit period. The actual measured consumption in the post-retrofit period is compared with an estimate of what the consumption would have been, in the post retrofit period, without the EEM.

The accuracy of this estimation is the key to this Option, using techniques from simple billing data comparison to multivariate regression analysis. The process involves using historical data (base year) to develop a model of the energy performance of the facility, then using the baseline model to estimate the “baseline energy” in the post-retrofit period that would have been measured if the EEM had not been installed.

The post-retrofit saving is the difference between the estimated “baseline energy” in the post-retrofit and the actual energy measured in the post-retrofit period.

Option C is intended for projects where expected savings are large compared to the random or unexplained energy variations which occur at the whole-facility level. If savings are large compared to the unexplained variations in the baseline energy data, identifying savings will be easy. Also the longer the period of savings analysis after the EEM installation, the less significant is the impact of short term unexplained variations. Typically savings should exceed 10% of the baseline energy for option C to be applied. Under this Option, continuous measurements of the entire facility’s energy use are taken throughout the reporting period.

**Example:** A entire building is retrofitted with numerous EEMs including lighting, HVAC, operator training, and occupant energy awareness campaign. In addition to their individual contribution to savings the EEMs also interact (e.g. reducing lighting impacts on heating and cooling) so the overall effect is complex. In this case, Option C is recommended for reporting comparative energy usage between the two periods.

Option C involves use of utility meters, whole facility meters, or sub-meters to assess the energy performance of an entire facility. The measurement boundary encompasses either the whole facility or a major section. This option determines the collective savings of all EEMs applied to the part of the facility monitored by the energy meter. Since whole facility

meters are used, savings reported under Option C include the positive or negative effects of any non EEM changes made in the facility.

### **6.9.5 Option D – Calibrated Simulation**

This is used for a single EEM or multiple EEMs within a whole building but where no base year data are available, either because no records are available or, because it is a new building. Post-retrofit measurements are used to calibrate the simulation model, and base year energy use is generated by the simulation model.

This Option is not used widely as it requires specialist simulation skills and software. It requires considerable skill in calibrated simulation.

**Example-1: Multifaceted energy management program impacting many systems in a facility and where no meter or facility existed in the baseline period.** After the new energy efficient building has been operating for 12 months. A simulation model based on technical inputs has been developed and calibrated with the actual operational consumption. This model can be used to estimate the likely consumption if the various EEMs had not been included. The consumption difference is a measure of the impact of the EEMs.

### **Example-2: New Building Designed to Be Better than Code**

A new building is being designed to use less energy than required by the ECBC (5 star rated) code. In order to qualify for say a government incentive payment, the owner was required to show that the building's energy use during the first year of operation after commissioning and full occupancy was less than 60% of what it would have been if it had been built just to comply with ECBC code.

Simulation software was used to predict energy use of the building under a known set of conditions. Post-retrofit measurements were used to calibrate the simulation model, and base year energy use was generated. The simulation was adjusted to match with the calibration data as much as possible. "Calibration error" is the set of differences between the modelled and calibration actual data points. Computer simulation was used extensively throughout the building design process to help meet a target energy use equal to 60% of the code.

### **6.9.6 Selecting the Option**

The selection of the M&V Option is a decision that is made collectively by the client, the ESCO and the M&V practitioner. The choice depends on the characteristics of the energy saving project, the specific EEM(s) proposed, data availability, budget, and professional judgment.

Options A and B are typically used if the EEM is about improving the efficiency of end-use equipment. They are also often selected when higher levels of uncertainty or risk in quantifying savings are acceptable.

Option A minimizes the costs of measuring and monitoring the energy savings. Measurement and verification costs for these options can be reduced by using statistically significant random samples when there is a large number of similar components involved (e.g., lighting fixture retrofits).

Option C should be used when there are more than one EEM and we cannot separate out their individual savings contributions and EEM interactions.

Option D should be used when no measurement data is available. It is not used very often for M&V as it requires the services of an energy simulation expert and hence adds to the cost of M&V.

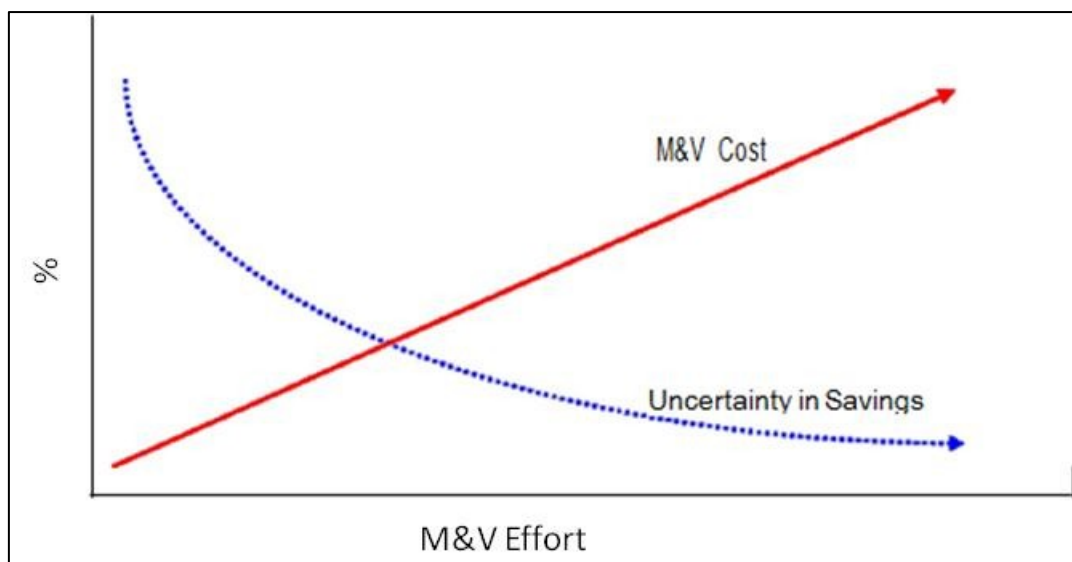
With Options C & D, uncertainty is reduced—accuracy in determining energy savings is improved. M&V cost will be higher due to increased use of metering, sub-metering, digital equipment, and more complex monitoring systems (hardware) that are used in capturing information to quantify savings. Such monitoring equipment might include sensing devices such as temperature sensors, flow meters, and pressure switches; communications equipment; or programmable controllers.

## **6.10 Uncertainty and M&V Cost**

Measurement is one of the basic elements of M&V. The measurement of any physical quantity includes errors because no measurement instrument is 100% accurate. Errors are the differences between observed and true energy use due to various factors such as option selected, the number of EEMs and the interactions among them, energy flows across the measurement boundary in Options A, B, or D, level of effort for establishing baseline conditions, sample sizes used for metering representative equipment, duration of the reporting period etc.

Thus, any statement of measured energy savings includes some degree of uncertainty. A goal for each M&V project is to balance the uncertainty in the reported savings values with the cost of performing M&V.

Reductions in uncertainty are obtained by limiting errors in the measurements and analyses conducted. For example, higher precision meters for measuring energy consumption may produce a final result with lower uncertainty, but cost will be more. Similarly, when the M&V project relies on sampling, a larger sample size will usually result in higher confidence level that will cost more. The participants responsible for creating and approving the M&V plan must consider how much accuracy they require, and at what cost (Figure 6.5).



**Figure 6.5: Balancing Uncertainty and M&V Costs**

However, there are certain norms to have a check on M&V cost. Overall M&V annual cost to determine savings should always be less than 10% of the annual project cost savings and should normally be between 3-5% for ESCO projects.

## 6.11 What is not M&V?

### 6.11.1 Difference between “Measurement & Verification” and “Monitoring and Verification”

People often confuse whether M in M&V is for ‘measurement’ or for ‘monitoring’. The basic difference between the two is of approach and purpose. Measurement and Verification (M&V) is the process of using measurement to reliably determine actual savings created within an individual facility by implementing an energy management program. Savings cannot be directly measured, since they represent the absence of energy use. Instead, savings are determined by comparing measured use before and after implementation of a project, making appropriate adjustments for changes in conditions.

On the other hand, Monitoring is the process of observing energy use for prediction, cost-control, diagnostic purposes and even legal compliance and may or may not involve measurement. All standards (ISO 50015) and protocols insist on inclusion of measurement in “Measurement & Verification”. Hence, we should always consider M for “measurement’ in M&V and not as “monitoring”.

### 6.11.2 Difference between M&V and Monitoring & Targeting

Monitoring and targeting includes the traditional energy monitoring, accounting, analysis and reporting functions. It has additional functionality that corrects the measured energy for changes in factors that influence consumption over time, such as weather, area, and

occupancy and production levels. M&T is very useful in identifying (targeting) EEMs based on comparative information between one period and another.

Even though there are similarities, Monitoring and targeting does not have the same focused purpose, discipline, rigour and transparency required for M&V. M&T ignores non-routine adjustments and interactive effects, whereas M&V considers such effects fully. M&V is concerned with measurement of actual energy performance while Monitoring & Targeting is concerned with the gap between actual energy performance and expected energy performance (target) to plan corrective measures.

## 6.12 Conclusion

M&V protocols and guidelines have been developed to provide a consistent and verifiable approach for determining savings for all types of energy savings projects. There are inherent errors and risks that contribute to savings uncertainty. A balance has to be found between the M&V cost and the savings uncertainty, considering project objectives and constraints.

### **The following should be always remembered about M&V:**

- M&V should be integral part of all types of energy savings project.
- There is no *absolutely* correct savings number. There is always some uncertainty.
- Savings cannot be measured. They are determined from the pre- and post-retrofit energy measurements.
- The measurement boundary for an EEM or a group of EEMs has to be defined.
- The Baseline Energy in the post-retrofit period is the base year Energy adjusted to the post-retrofit conditions.
- The “savings” are the difference between the adjusted Baseline Energy and the actual Post-Retrofit Energy, both in the post-retrofit period.
- A foundation for proper M&V is laid by preparing, documenting and following an M&V Plan
- The basic approach comprises planning, designing, and implementing project-specific M&V and reporting and verifying the savings.
- The M&V concepts and methodologies are quite simple and are based on common sense and good quality management practices.

## M&V Plan

The preparation of an M&V Plan is a recommended part of savings determination. It also allows to direct actions; ensure proper information is archived for later use and resolve major issues to avoid possible conflicts between parties involved that may arise once results (savings) are known.

Advance planning ensures that all data needed for savings determination will be available after implementation of the EEM(s), within an acceptable budget. Data from the baseline and details of the EEMs may be lost over time. Therefore, record them for future reference in case conditions change or EEMs fail. Documentation should be easy to find and easy to understand by verifiers and others, because years may pass before these data are needed. A complete M&V Plan should include discussion of the following topics:

1. Scope & Purpose – This should include a. the organization for whom the M&V is undertaken, b. Purpose(s) of M&V, c. parties responsible for M&V, their roles and relationship with organization, d. confidentiality requirements, e. parties who will receive the results, f. M&V method used, g. potential consequential effects etc.
2. EEM details - Describe the EEM, its intended result, and the operational verification procedures that will be used to verify successful implementation of each EEM. Identify any planned changes to conditions of the baseline, such as unoccupied building temperature settings.
3. Selected Option and Measurement Boundary - Specify the Option which will be used to determine savings. Identify the measurement boundary of the savings determination. The boundary may be as narrow as the flow of energy through a pipe or wire, or as broad as the total energy use of one or many facilities. Describe the nature of any interactive effects beyond the measurement boundary together with their possible effects.
4. Baseline: Period, Energy and Conditions - Document the facility's baseline conditions and energy data, within the measurement boundary. In energy performance contracts, baseline energy and baseline conditions may be defined by either the owner or the ESCO, providing the other party is given adequate opportunity to verify them. This baseline documentation should include: a) Identification of the baseline period b) All baseline energy consumption and demand data, c) All independent variable data coinciding with the energy data (e.g. production rate, ambient temperature) d) All static factors coinciding with the energy data.
5. Reporting Period - Identify the reporting period. This period may be as short as an instantaneous measurement during commissioning of an EEM, or as long as the time required to recover the investment cost of the EEM program.
6. Basis for Adjustment - Declare the set of conditions to which all energy measurements will be adjusted. The conditions may be those of the reporting period or some other set of fixed conditions.
7. Analysis Procedure - Specify the exact data analysis procedures, algorithms and assumptions to be used in each savings report. For each mathematical model used, report all of its terms and the range of independent variables over which it is valid.
8. Energy Prices - Specify the energy prices that will be used to value the savings, and whether and how savings will be adjusted if prices change in future.

9. Data gathering Plan and Meter Specifications - Specify the metering points, and period(s) if metering is not continuous. For non-utility meters, specify: meter characteristics, meter reading and witnessing protocol, meter commissioning procedure, routine calibration process, and method of dealing with lost data.

10. Roles and Responsibilities - Assign responsibilities for reporting and recording the energy data, independent variables and static factors within the measurement boundary during the reporting period.

11. Expected Accuracy - Evaluate the expected accuracy associated with the measurement, data capture, sampling and data analysis. This assessment should include qualitative and any feasible quantitative measures of the level of uncertainty in the measurements and adjustments to be used in the planned savings report.

12. Resources required - Define the budget and the resources required for the savings determination, both initial setup costs and ongoing costs throughout the reporting period.

13. Report Format - Specify how results will be reported and documented. Formats to be used for reporting results need to be finalized.

Depending upon the circumstances of each project, some additional specific topics should also be covered in a complete M&V Plan:

a. For Option A, document detailing stipulated parameters with justification and the overall significance of these parameters to the total expected saving, the uncertainty inherent in the stipulation; and periodic inspection in reporting period

b. For Option D, name and version number of simulation software; Input data and method of measuring any parameters used to support input values; Output from software; calibration data, future changes and accuracy achieved by simulation.



**ANNEXURE 6–ii****CONTENTS OF A FULL M&V REPORT**

M&V Reports should be prepared and presented as defined in M&V Plan. These should include at least:

- Observed data of the reporting period: the measurement period, start and end points in time, the energy data, and the values of the independent variables
- Description and justification for any corrections made to observed data
- For Option A, the agreed estimated values
- Energy price schedule used
- All details of any baseline non-routine adjustment performed. Details should include an explanation of the change in conditions since the baseline period; all observed facts and assumptions, and the engineering calculations leading to the adjustment.
- Computed savings in energy, demand and monetary units.
- Input from the review of the report with the facility operating staff

M&V reports should be written to their readers' levels of understanding. Energy managers should review the M&V reports with the facility's operating staff. Such reviews may uncover useful information about how the facility uses energy, or where operating staff could benefit from more knowledge of the energy-consumption characteristics of their facility. While preparing reports, the needs and understanding levels of the users of the M&V reports should also be kept in mind.

## M&V CASE STUDY: EEM: STEAM TRAP REPLACEMENT

### A. M&V Option A selected.

This measure involves replacing steam traps. This will improve return water quantity and temperature, which will reduce boiler consumption and water treatment chemicals for makeup water.

### B. M&V Plan Description

Option A (Retrofit Isolation with Key Parameter Measurement) will be used to quantify the energy consumption savings associated with steam trap replacement.

### C. Why M&V Option A was selected?

- This measure is detailed with multiple measurements and calculations required to verify savings. It is recommended to perform a routine steam trap assessment to verify savings are being maintained.
- Option A is recommended for verification of the performance of this EEM.
- Performance parameters (Table 6.2) include a steam trap assessment of the entire facility. This will identify the failed traps. Once the failed traps have been identified, the steam pressure and orifice size will be required to calculate losses. This will be done during the baseline development, post-installation, and performance period with 20% of the steam traps being assessed every year and rotated.

**Table 6-2: M&V Plan Performance and Operational Parameters**

Parameter	Period	Population	Measurement
<b>Steam Trap Assessment</b>			
Performance	Baseline	Entire facility	Thermograph/ultrasonic
Performance	Post-Installation	Entire facility	Thermograph/ultrasonic
Performance	Performance	20% rotating	Thermograph/ultrasonic
<b>Steam Pressure and Orifice Size</b>			
Performance	Baseline	For all traps failed	Spot measurement
Performance	Post-Installation	For all traps failed	Spot measurement
Performance	Performance	Based on baseline	None
Parameter	Period	Population	Measurement
<b>Steam Trap Operation</b>			
Operation	Baseline	Entire facility	Hours based on boiler logs
Operation	Post-Installation	Based on baseline	None
Operation	Performance	Based on baseline	None

### D. M&V Performance Assurance Activities

- Verify failed traps have been properly replaced.
- Verify savings through calculated losses by verifying trap orifice size and steam pressure.
- Obtain customer approval of all stipulated performance and operational parameters shown in the baseline and post-installation parameter value tables.

## 7. BEST PRACTICES, TECHNOLOGIES AND CASE STUDIES – ELECTRICAL AND THERMAL SYSTEM

### 7.1 Introduction

Energy efficiency should be viewed as an energy reserve just like fossil fuel reserves. There is a very significant potential (15–25%) to improve industrial energy efficiency using existing, proven technologies that are cost-effective today, as well as applying new technologies. Best practices in Electrical and Thermal, along with relevant case studies, covering electrical and thermal areas are presented in this chapter.

Electrical	Thermal
<ul style="list-style-type: none"> <li>✚ Energy Efficient Motors</li> <li>✚ Applications of VFD               <ul style="list-style-type: none"> <li>○ Fans</li> <li>○ Pumps</li> <li>○ Compressors</li> </ul> </li> <li>✚ High COP chillers</li> <li>✚ Internet of Things (IOT) Applications for Chiller System</li> </ul>	<ul style="list-style-type: none"> <li>✚ Pressure reducing turbine</li> <li>✚ Heat pump</li> <li>✚ Heat Pipe applications</li> <li>✚ Condensing boiler</li> <li>✚ Absorption chillers</li> <li>✚ Trigeration</li> <li>✚ Organic Rankine Cycle</li> </ul>

### 7.2 Best Practices and Technologies in Electrical System

#### 7.2.1 Case for Energy Efficient Motors

Electric motors convert electrical power into mechanical power within a motor-driven system. In industrial applications, electric motor driven systems are used for various applications such as pumping, compressed air, fans, conveyors etc. The system approach for optimizing energy efficiency of motor-driven system is recommended, which include the following:

- ✚ Use of energy efficient motors;
- ✚ Selecting the driven equipment—like pumps, fans, compressors, transmissions, variable speed drives—right type and size, and high efficiency;
- ✚ Efficient operation of the complete system.

From the motor perspective, when buying a new motor, operating cost and not just the purchase cost should be the main consideration. In a single year the cost of energy can be up to 10 times the purchase cost. Over the life of the motor it is by far the most significant cost. Old motors, typically more than 15 years and operating for over 5000 hours in a year can be considered for replacement with energy-efficient motors to reduce energy costs.

#### IE Classification

International Efficiency (IE) is a new trend around the world in describing the energy efficiency of motors. The IE classes IE1 to IE4 are well developed, while the IE5 is under

preparation. The classification method allows for further improvement in the energy efficiency of motors. The IE Classification as per IEC 60034-30-1 is shown in Table 7.1.

**Table 7.1: IE Classes**

Class Type	Class Number
Standard efficiency	IE1
High efficiency	IE2
Premium efficiency	IE3
Super premium efficiency	IE4

IE4 represents the highest energy efficiency while IE1 represents the least energy efficiency. In other words, the higher the class number, the higher will be the motor efficiency. IE5 is to be incorporated in the next edition of IEC 60034-30-1, with a goal to obtain an energy loss reduction of 20% relative to IE4.

### **Energy Savings with Energy Efficient Motor**

The annual energy saving by upgrading to more efficient motor is calculated as per the following formula:

**Annual Energy Saving (kWh per year) =**

**Annual Energy Consumption of Motor (kWh per year) x Percentage of Energy Saving (%)**

The energy saving (%) can be calculated using the following formula:

$$\text{Percentage of Energy Saving (\%)} = \left( 1 - \frac{\text{Efficiency of Old Motor (\%)}}{\text{Efficiency of New Motor (\%)}} \right) \times 100\%$$

If the annual energy consumption of motor is not available, it can be estimated with the following formula:

$$\begin{aligned} \text{Annual Energy Consumption of Motor (kWh per Year)} \\ = \frac{\text{Rated power of motor}}{\text{Rated efficiency}} \times \text{rated hours per day} \times \text{operating days per year} \end{aligned}$$

### **Replacing IE1 motor with IE3**

The information regarding the old motor and the operation pattern is as follows:

Rated Power	37 kW
No. of Poles	4
Efficiency	91.2 (IE1)
Operating Hours per Day	10
Operating Days per Year	360

The annual energy consumption is calculated as follows:

Annual Energy Consumption (kWh per Year) = 37 kW/0.912 x 10 hours per day x 360 days/year = 1,46,052 kWh

It is proposed to replace IE1 is replaced with IE3 motor as per following specifications:

Rated Power	37 kW
No. of Poles	4
Efficiency	93.9 (IE3)
Designed Lifespan	400,000 hours

The percentage of energy-saving and the anticipated annual energy saving is calculated below:

$$\text{Percentage of Energy Saving (\%)} = \left(1 - \frac{91.2}{93.9}\right) \times 100\% = 2.88\%$$

$$\begin{aligned} \text{Annual Energy Saving (kWh per Year)} &= 1,46,052 \text{ kWh per year} \times 2.88/100 \\ &= 4206 \text{ kWh/Year} \end{aligned}$$

#### **Replacing IE1 motor with IE4**

If the new motor is IE4 with following specifications, energy savings is as follows:

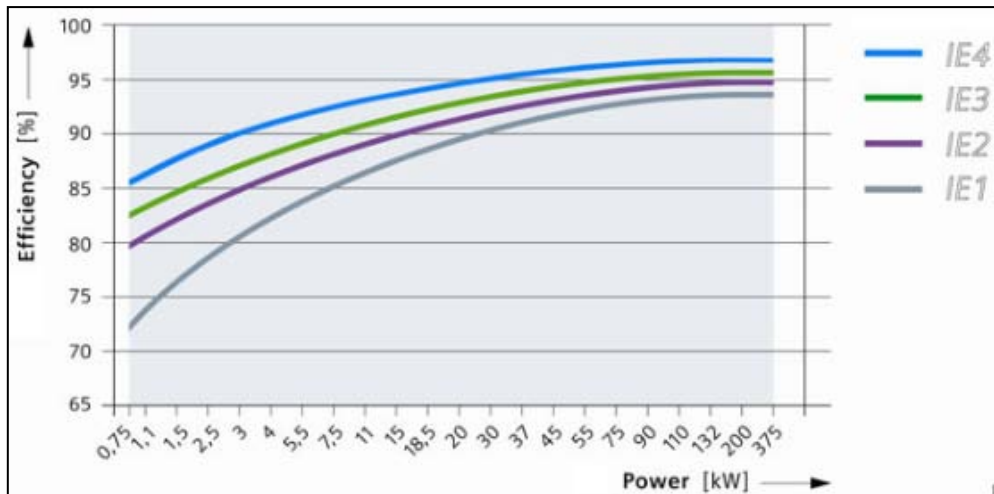
Rated Power	37 kW
No. of Poles	4
Efficiency	95.2 (IE4)
Designed Lifespan	400,000 hours

The percentage of energy-saving and the anticipated annual energy saving is calculated as follows:

$$\text{Percentage of Energy Saving (\%)} = \left(1 - \frac{91.2}{95.2}\right) \times 100\% = 4.2\%$$

$$\begin{aligned} \text{Annual Energy Saving (kWh per Year)} &= 1,46,052 \text{ kWh per year} \times 4.2\% \\ &= 6134 \text{ kWh/Year} \end{aligned}$$

Typical motor rating and efficiency of IE1, IE2, IE3 and IE4 is shown in Figure 7.1.



**Figure 7.1: Efficiency classes IE1 to IE4**  
Source: IEC 60034-30-1

## 7.2.2 Variable Frequency Drive (VFD) Applications

The potential for energy saving from speed reduction depend on the characteristics of the load being driven. There are three main types of load prevalent in industry: variable torque, constant torque and constant power.

### Variable torque load

Variable torque loads are typical of centrifugal fans and pumps and have the largest energy saving potential. They are governed by the Affinity Laws which describe the relationship between the speed and other variables:

The change in flow varies in proportion to the change in speed:

$$Q1/Q2 = (N1/N2)$$

The change in head (pressure) varies in proportion to the change in speed squared:

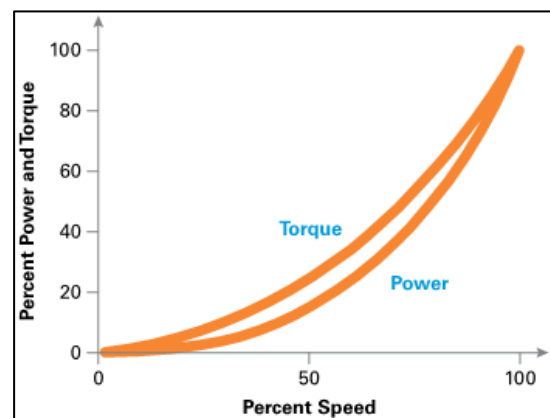
$$H1/H2 = (N1/N2)^2$$

The change in power varies in proportion to the change in speed cubed (Figure 7.2):

$$P1/P2 = (N1/N2)^3$$

Where, Q = volumetric flow, H = head (pressure), P = power, N = speed (rpm)

The power–speed relationship is also referred to as the ‘Cube Law’. When controlling the flow by reducing the speed of the fan or pump, a relatively small change in speed will result in a large reduction in power absorbed.



**Figure 7.2: Variable Torque Load**

### Constant torque load

Typical constant torque applications include conveyors, agitators, crushers, positive displacement pumps and air compressor. On constant torque loads the torque remains constant with speed and the power absorbed is directly proportional to the speed (Figure 7.3); this means that the power consumed will be in direct proportion to the useful work done, for example a 50% reduction in speed will result in

50% less power being absorbed or consumed.

Although the potential energy savings from speed reductions are not as attractive as that with variable torque loads, they are still worth investigating to achieve efficient process control and energy savings.

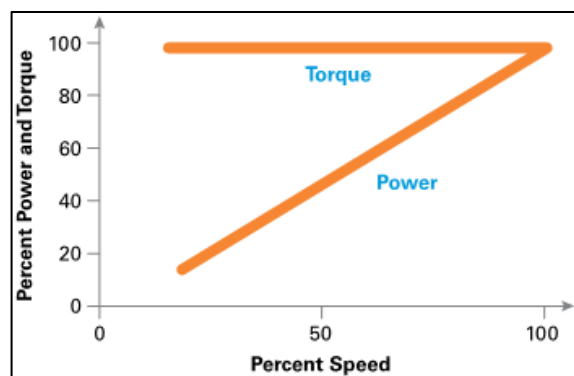


Figure 7.3: Constant torque Load

### Constant Power

On constant power loads, the power absorbed is constant while the torque is inversely proportional to the speed (Figure 7.4). The torque loading is a function of speed up to 100% operating speed. As the speed of the operation is decreased, the torque increases so that the power required remains essentially constant. Typical applications are saws, grinders, and machine tools. The installation of VFD is not recommended for constant power applications.

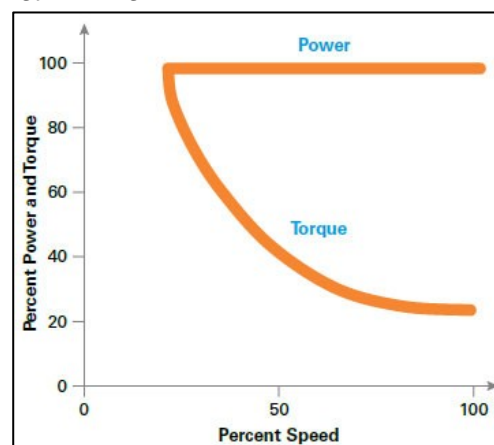


Figure 7.4: Constant Power Control

### VFD for Fans

Dampers are often used to regulate the flow of fans in applications such as most kinds of ventilation systems, air extract systems, industrial cooling, and combustion-air control and flue gas evacuation systems for boilers. With damper control, the input power reduces as the flow rate decreases. If dampers are replaced with VFD control, input power is reduced much more significantly as per cube law as shown in Figure 7.5.

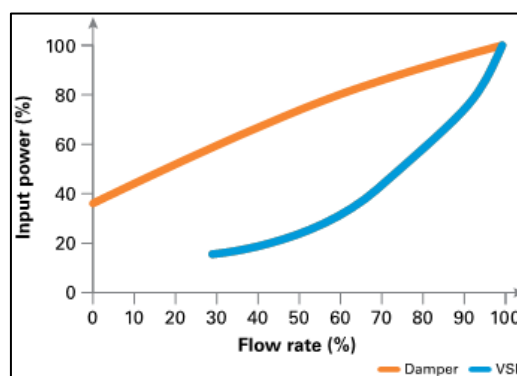


Figure 7.5: Damper versus VFD

One of the limitations of VFDs is that the speed can be reduced below 30% as cooling capacity of the motor will be affected.

### VFD versus Outlet Damper in a Fan

The power consumptions of fan with variable speed method and outlet damper method, and their associated costs of operation are determined for a given load profile as shown.

Flow (% Flow)	Duty Cycle (% of time)
100	10
80	40
60	40
40	10

100% flow is equivalent to 100 CFM

#### Outlet damper control

For each duty (operating) point, the required power corresponding to the fan flow can be obtained from the fan curve. This power is multiplied by the fraction of the total time, for which the fan operates at this point. These "weighted horsepower" are then summed to produce an average horsepower that represents the average energy consumption of the fan over the entire duty cycle.

Flow (CFM)	Duty Cycle (%)	Power (HP)	Weighted Power(HP)
100	10	35	3.5
80	40	35	14
60	40	31	12.4
40	10	27	2.7
<b>TOTAL (Outlet damper control)</b>			<b>32.6</b>

#### VFD control

To assess the energy savings with VFD, calculations are carried out using flow-power relationship:  $P_2/P_1 = (Q_2/Q_1)^3$  as  $Q_2/Q_1 = N_2/N_1$ . When  $Q_1 = 100\%$  and  $W_1 = 35$  HP, the values of  $W_2$  for various values of  $Q_2$  are as follows:

<b>Q<sub>2</sub></b>	100	80	60	40
<b>W<sub>2</sub></b>	35	18	7.56	2.24

These calculated values match with the points available on the fan curve. The weighted power can be calculated as follows:

Flow (CFM)	Duty Cycle	Power (HP)	Weighted Power(HP)
100	10	35	3.5
80	40	18	7.2
60	40	7.56	3.024
40	10	2.24	0.224
<b>TOTAL (VFD control)</b>			<b>13.9</b>



The cost savings with VFD if the system operates 18 hours per day (540 hours per month), and the cost of electricity is Rs. 5.5 per kWh.

Parameters	Outlet damper	Variable speed
Weighted Horsepower	32.6	13.9
kW/HP	0.746	0.746
hours/month	540	540
kWh/month	13,133	5,599
Cost (Rs./kWh)	5.5	5.5
<b>Total operating cost(INR)</b>	<b>72,229</b>	<b>30,797</b>
<b>Savings (INR)</b>	<b>41,432</b>	

### VFD for Pumps

Unlike VFD applications for fans, pump speed adjustment should be carefully evaluated. The best application for VFD is on pumping system with only frictional head and no static head. Using a VFD to control the flow rate from a pump rather than using simple throttle control, can result in large power savings and therefore cost savings. For example, when flow demand decreases by 50%, the head is reduced by 75%, and the power absorbed is reduced by 20%

On pumping systems with a high static head, for example, boiler feed-water pumps or high lift applications, where the pump must overcome the resistance to lifting the water before any flow starts, the energy savings with VSDs will be reduced. This is because higher speeds need to be maintained in order to overcome the additional resistance due to the high static head.

#### Higher static head, lower VFD savings in pumps

For pumps with high static head, *Affinity Laws* cannot be directly applied. For example consider a system that utilizes a 5 HP pump, operating at 60% flow continuously. If static head is ignored and Affinity Law is applied, 60% flow would allow VFD to modulate to 60% speed, reducing the power required from 5 HP to 1.1 HP. Energy savings is 78%

However, if the system has a minimum static head of 30 ft (9.1 m) and the design static head is 40 ft. (12.2 m). If the required speed to overcome this static pressure is included, calculated power is 4.4 HP. Energy savings is now only 15%.

In high static head applications, reducing pump speed also risks inducing vibrations and creating performance problems that are similar to those found when a pump operates against its shutoff head (zero flow through the system). Operators should review the performance of VFDs in such applications and consult VFD manufacturers so as to avoid the damage that may result when a pump operates too slowly against high static head.

In applications, where the head must be kept constant but flow may vary, installing a variable frequency drive is not recommended. Instead, a multiple pump system where pump will start or stop if discharge pressure starts to drop or rise is recommended.

For positive displacement pump, energy consumption tends to be directly proportional to the volume pumped and energy saving is easily quantified.

### **VFD Application Guidelines in Pumping System**

Applications where the static head is greater than 50% of the total head are not usually good applications for VFD variable speed pumping. This is because of the following reasons:

- The system curve is very flat, and the pump efficiency at the reduced speed operating point falls off rapidly. The opportunity for energy savings at reduced speed is minimal.
- The flat system curve also limits the useable speed reduction range.

**For variable speed applications, select pumps with the full speed operating point to the right of BEP whenever possible.**

- Selecting operating point to the right of BEP improves efficiency at reduced speed since the intersection point with the system curve moves toward BEP when speed is reduced.
- Variable speed applications often allow the use of smaller, less expensive pumps.

### **VFD for Air compressors**

The potential for energy savings from using VFDs for air compressors will depend on the control system being replaced. Typical control adopted in industry is load/unload control (Figure 7.5). Unlike fans and pumps most air compressors present a constant-torque load and have less scope for energy savings, nevertheless it is economically viable to fit VFDs to air compressors where the average loading is less than 75%.

#### ***Load/unload control***

Compressor pressure is set between high pressure and low pressure, which is determined based on pressure required in the system. Compressor unloads when high pressure is reached and loads when low pressure is reached. When demand for compressed air is fully met—when compressed air supply is not needed—the suction valve of the compressor closes and the compressor becomes unloaded. When the demand for compressed air supply is resumed, the suction valve opens and the compressor becomes loaded. The compressor suction valve is opened or closed to match supply with demand as sensed by a pressure regulator. This type of control is also called suction valve control (Figure 7.6).

Typical unloading power is 25% of full load power for reciprocating compressor and 35–40% of full load power for screw compressor.

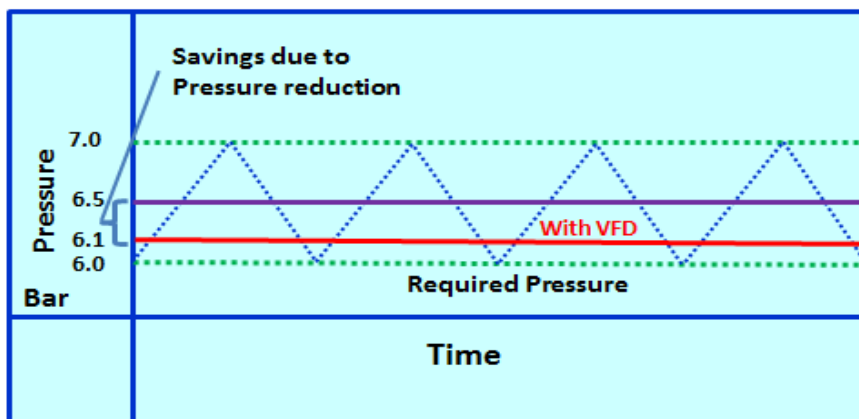


Figure 7.6: Load/Unload Control

**Inverter (VFD) control**

In inverter control or variable frequency drive (VFD) control, the speed of the compressor motor varies with air demand. When air demand is less, the speed of the motor is reduced and vice versa. As a result, constant pressure is maintained (Figure 7.7). There is a direct relationship between compressor power and air delivered. Inverter changes the speed of the motor by converting 50-Hz alternating current to direct current, and then reconverts it to AC at the frequency required to run the motor at the desired speed.

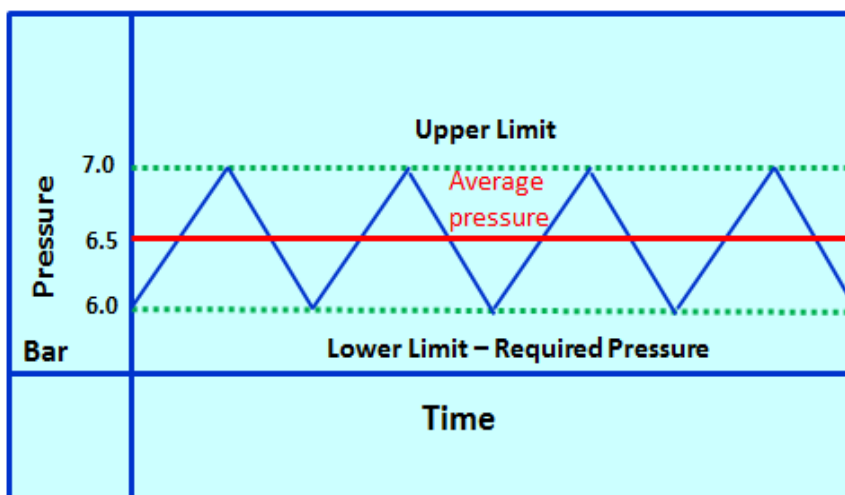


Figure 7.7: VFD Control

**Power savings with Load/Unload (Suction control) vs VFD**

Three cases comparing Load/Unload with VFD are presented for a screw compressor of following specification:

Type: <b>Screw Type</b>	Control: <b>Suction Valve and VFD control</b>
Rated capacity: <b>60 m<sup>3</sup>/hr</b>	Motor rating: <b>7.5 kW</b>
Rated pressure: <b>830 kPa (Maximum)</b>	Annual running hours: <b>5400</b>

**Case I**

Operation	Flow Rate (m <sup>3</sup> /hr)	Pressure (kPa)	Power (kW)	On/Un loading time (sec)	Average Power (kW)
Loading	30	500-600	6.6	33.6	5.37
Unloading			4.3	38.5	
VFD	30	550	4.5	-	4.50
				-	
<b>Savings per annum (kWh)</b>					<b>4708</b>

**Case II**

Operation	Flow Rate (m <sup>3</sup> /hr)	Pressure (kPa)	Power (kW)	On/Un loading time (sec)	Average Power (kW)
Loading	30	600-700	7.2	40.5	6.09
Unloading			4.75	33.5	
VFD	30	610	4.8	-	4.80
				-	
<b>Savings per annum (kWh)</b>					<b>6971</b>

**Case III**

Operation	Flow Rate (m <sup>3</sup> /hr)	Pressure (kPa)	Power (kW)	On/Un loading time (sec)	Average Power (kW)
Loading	40	500-600	6.75	53	5.89
Unloading			4.3	28.5	
VFD	40	550	5.3	-	5.30
				-	
<b>Savings per annum (kWh)</b>					<b>3204</b>

**7.2.3 High COP Chillers**

In many commercial and industrial facilities, space cooling and process refrigeration represents one of the largest energy costs. Vapour compression chillers are used extensively for large facility space cooling and in industrial process liquid cooling. Improving chiller efficiency can significantly reduce energy usage without affecting comfort or production.

A liquid chilling system cools water or secondary coolant for air conditioning or process refrigeration. Liquid (usually water) is supplied to the facility at a temperature of 7<sup>o</sup>C (for air conditioning) and is returned at some higher temperature after it has removed heat from the facility. Under full load conditions, the water will usually undergo a 10<sup>o</sup>C temperature rise. As the chiller removes heat from this water, it rejects this heat into the ambient air, whether directly by means of a refrigerant-to-air heat exchanger, or indirectly by means of a separate water loop and a cooling tower.

A chiller has four primary components: compressor, compressor drive, evaporator, and condenser. The evaporator and condenser serve as heat exchangers which transfer heat

between the water and the refrigerant. Chillers can be mainly categorized based on the type of compressor as electrically driven vapour compression-type chillers, or absorption-type chillers.

Vapour compression chillers utilize electric motors to drive the compressor. These chillers can be further categorized according to the type of compressor being used.

**Reciprocating Compressor Chillers** are well-suited for air-cooled condensers and low-temperature application.

**Centrifugal Compressor Chillers** are similar to fans or blowers. They are generally quieter, require less maintenance, and have less vibration than reciprocating compressors. They are mostly water-cooled.

**Screw Compressor Chillers** are more compact than either the centrifugal or reciprocating compressor. Screw type systems are better suited for low temperature applications.

**Scroll Compressor Chillers** They are relatively new in commercial applications, very quiet, and efficient. Scroll compressors are available up to 60 tons.

When comparing chillers for energy efficiency, auxiliary energy requirements such as condenser and chilled water pumps, cooling tower fans, as well as the cost of water treatment should also be taken into account.

Vapour compression chillers can be compared based on the input power in kilo Watts required to deliver one ton of refrigeration or air conditioning, or KW/Ton. A lower kW/ton rating indicates higher efficiency. Few terms are defined here.

**Tons:** One ton of cooling is the amount of heat absorbed by one ton of ice melting in one day, which is equivalent to 12,000 Btu per hour (h), or 3.516 kilowatts (thermal) or 3024 kCal/hr.

**Coefficient of performance (COP):** The ratio of the cooling capacity output power to the power input to compressor at any given set of rating conditions, expressed as watts of output per watts of input.

$$\mathbf{kW/ton = 3.516/COP; COP = 3.516/(kW/ton)}$$

Chillers are broadly classified based on the compressor type, and type of cooling (air-cooled or water-cooled). Manufacturers' literature for vapour compression chillers will generally give the input KW along with the cooling capacity in tons. Although each chiller will have its own rating assigned by the manufacturer, typical efficiency ranges along with sizes are given in Table 7.2.

**Table 7.2: Typical Compressor Sizes and Efficiencies**

<b>Compressor Type</b>	<b>Compressor KW/Ton</b>	<b>Sizes (Tons)</b>
<b>Air-Cooled</b>		
Reciprocating	1.0 - 1.3	3 - 450
Centrifugal	0.7 - 0.9	80 - 1300
Screw	0.7 - 1.2	45 - 380
Scroll	up to 1.2	up to 60
Auxiliary KW/Ton = 0.19 KW/Ton		
<b>Water-Cooled</b>		
Reciprocating	0.8 - 0.9	3 - 450
Centrifugal	0.5 - 0.8	80 - 8500
Screw	0.6 - 0.7	50 - 1300
Auxiliary KW/Ton = 0.21 KW/Ton		

The following points regarding chillers should be remembered by energy auditors/energy managers:

The efficiencies for water cooled units are generally higher than those for air-cooled (where an air-to-refrigerant heat exchanger is utilized), but there is a slight increase in auxiliary KW/Ton. This efficiency improvement in water-cooled chiller is the result of more efficient heat transfer and consequently, lower condensing temperatures.

Compressor efficiency depends on the type of compressor being utilized. COP design data can be compared with actual COP data to diagnose performance issues. Reciprocating compressors generally operate better when partly loaded while screw compressors operate best under fully-loaded conditions.

Each chiller has a different COP. The COP varies with the cooling load on a chiller. Operating efficiencies of chillers are more important than full-load efficiency as chillers operate at part-load most of time.

#### ***Case for High efficiency (COP) chiller***

Chiller manufacturers have made significant improvements in the operating efficiency of their units over the past 20 years. A chiller more than ten years old will typically have a full-load efficiency rating of 0.75 to 1.00 kW per ton. High efficiency centrifugal chillers will have a full-load efficiency rating of about 0.50 kilowatts (kW) per ton or even lower (in the range of 0.40 kW per ton). For the same load, a new, high efficiency chiller will consume only 60% of the energy consumed by an old chiller.

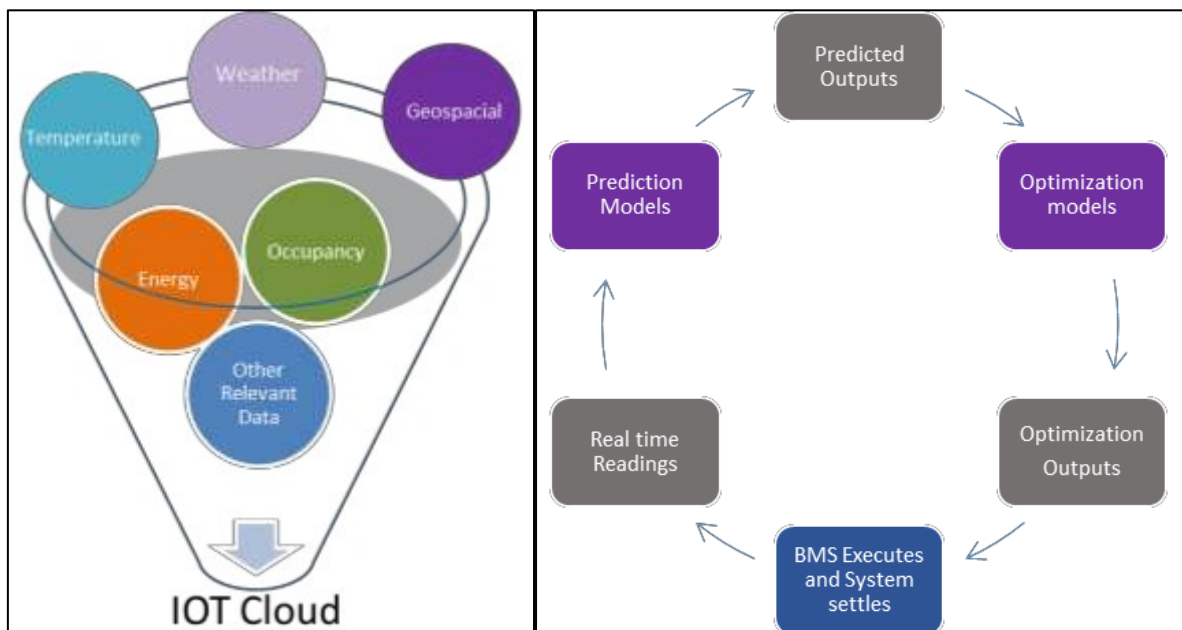
As a rule of thumb, the best candidates for replacement are those chillers that are more than 20 years old, operating at least 1,000 hours per year, serving a number of critical loads in the building, and requiring higher maintenance.

### 7.2.4 Internet of Things (IOT) Application for Chiller System

Cooling load in a building depends on various factors such as outside dry bulb temperature, number of occupants etc. The chiller water temperature which influences the cooling of space is normally set for a particular temperature, typically 7°C. If the cooling loads decrease or increase, the chilled water temperature drops or rises correspondingly. Manual intervention is needed to periodically reset chilled water temperature corresponding to dynamic change in cooling load.

In an IOT and Machine Learning controls scenario (Figure 7.8 (a) and (b)), temperatures of cooling space, chilled supply and return water temperature, outside air temperature, occupancy are measured. The objective is as follows:

- To maintain a set cooling space temperature by varying temperature of chilled water supply as per the cooling load to reduce compressor power.
- To monitor the environment in building space, improve comfort, and reduce operational costs
- To proactively identify conditions that might cause a climate-related issue, and correct the conditions before they become severe
- To control chilled water temperature remotely (without manual intervention).

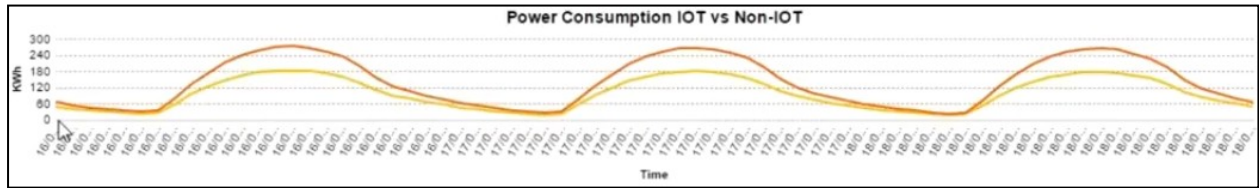


**Figure 7.8 (a) Multiple datasets from sensor networks**

**(b) Optimization Approach Real Time Machine Learning Model**

It involves setting logic, rules, notifications, creating predictive analytics models and instructions that would trigger chiller system if a particular rule is violated. In case of reduced cooling load, chilled water set point rule triggers notifications which instruct chiller system to correct chiller system set point. This control happens in real-time and real-time energy savings is achieved using automation to feed machine-learning intelligence back into the

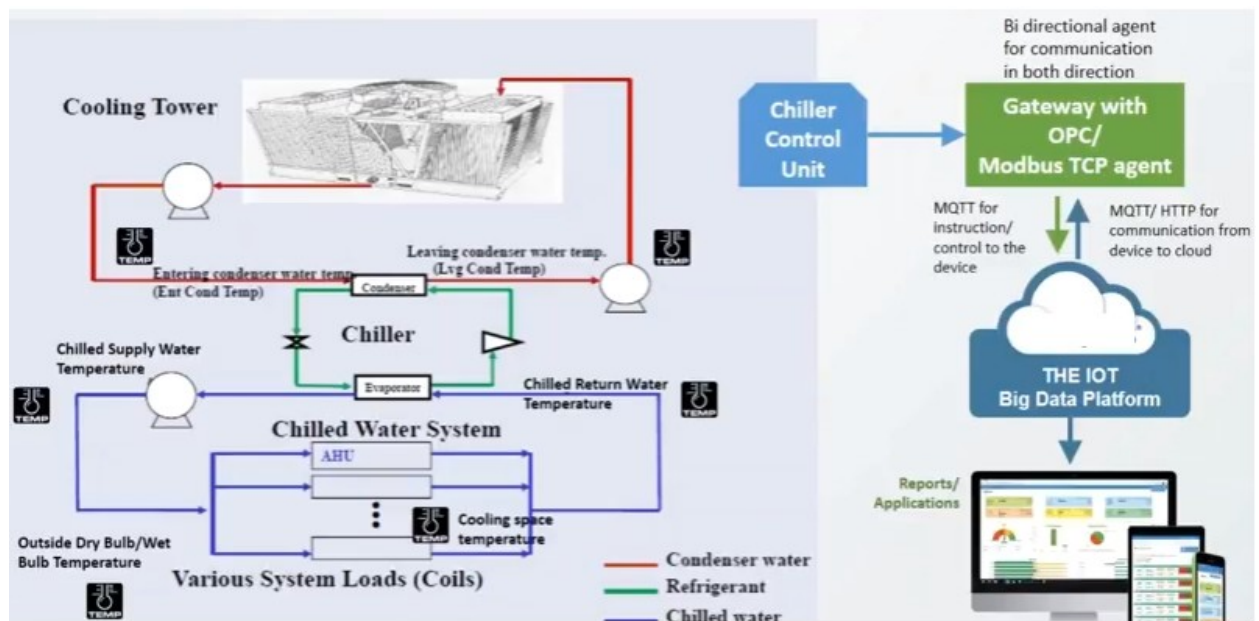
building management system (using artificial intelligence). Figure 7.9 illustrates compressor power with and without IOT.



**Figure 7.9: Compressor Power Consumption – IOT vs Non-IOT**

Same concept can be extended to condenser cooling circuit. It involves varying the temperature of condenser as the wet bulb temperature of the air varies.

Setting up IOT will involve installing temperature sensors at various points (shown as black boxes) in Figure 7.10. These sensors send data to big data platform and analytics (analysis of data) is performed in real-time and notification is send in real-time to take corrective action.



**Figure 7.10: IOT for Chiller System Efficiency**



## 7.3 Best Practices and Technologies in Thermal System

### 7.3.1 Pressure Reducing Turbine

The steam pressure is generally throttled and controlled to reduce pressure using pressure reducing valves (PRV). The throttling process is isenthalpic which means enthalpy before and after throttling is constant, and no energy output can be produced. Alternatively if pressure is reduced through turbine (backpressure type), energy can be produced along with low pressure steam for process. Although steam consumption is increased marginally, net energy savings can be achieved.

#### Case Study: Pressure Reducing Turbine Application (Figure 7.11)

Steam is generated in the boilers at pressure of 7–10.5 kg/cm<sup>2</sup> and steam pressure is reduced in the PRV's/PRDS to lower pressure of 2.5 kg/cm<sup>2</sup> to 3.0 kg/cm<sup>2</sup> required for the process. After installation of steam turbine, reduction of steam pressure in PRV's/PRDs is avoided and electrical power is produced from generator coupled to the turbine. Steam turbine is installed in parallel to PRV/PRDs, and steam energy which would have been wasted due to pressure reduction, is recovered in the form of electrical power, thus reducing power cost.

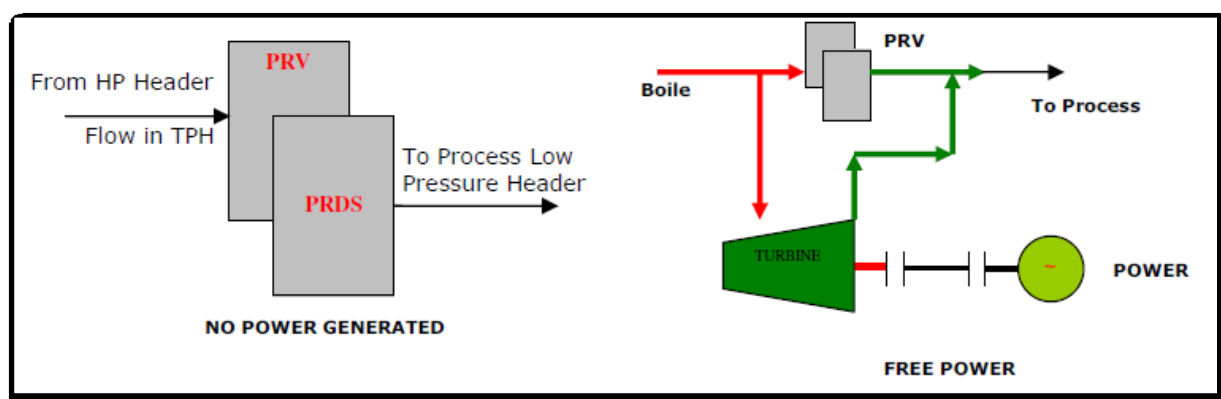


Figure 7.11: Pressure Reducing Turbine Application

#### Turbine Specifications

S. No.	Parameter	Unit	Value
1	Rated Capacity of the Turbine Alternator	kW	40
2	Voltage	V	433
3	Steam Inlet Flow to Turbine	TPH	3
4	Steam Outlet Flow of Turbine	TPH	3
5	Steam Inlet Pressure to Turbine	kg/cm <sup>2</sup>	10.5
6	Steam Outlet Pressure of Turbine	kg/cm <sup>2</sup>	3.5

### Cost savings

S. No.	Parameter	Unit	Value
1	Turbine capacity	kW	40
2	Annual Operating hours- 24 hrs/day and 350 days/annum	hours	8400
3	Turbine Load factor	%	90
4	Annual electrical savings	kWh	302400
5	Electricity cost per unit	`/kWh	5.6
6	Total cost savings	`(Lakh)/annum	16.9
7	Total investment	`(Lakh)	34.50
8	Simple payback	Years	2

Source: Detailed Project Report on Energy Conservation Turbine (40 kW), Textile SME Cluster, Surat, Gujarat (India) New Delhi: Bureau of Energy Efficiency; Detail Project Report No.: SRT/TXT/ECT/03

### 7.3.2 Heat Pump

Heat Pump is a device which pumps heat from, one or more low temperature sources to one or more high temperature sinks simultaneously, with the help of an external source of energy. Heat pumps are designed to move thermal energy opposite to the direction of spontaneous heat flow by absorbing heat from a cold space and releasing it to a warmer one. Heat pumps are very efficient for heating and cooling systems and they can significantly reduce the energy costs. Schematic diagram of heat pump is shown in Figure 7.12.

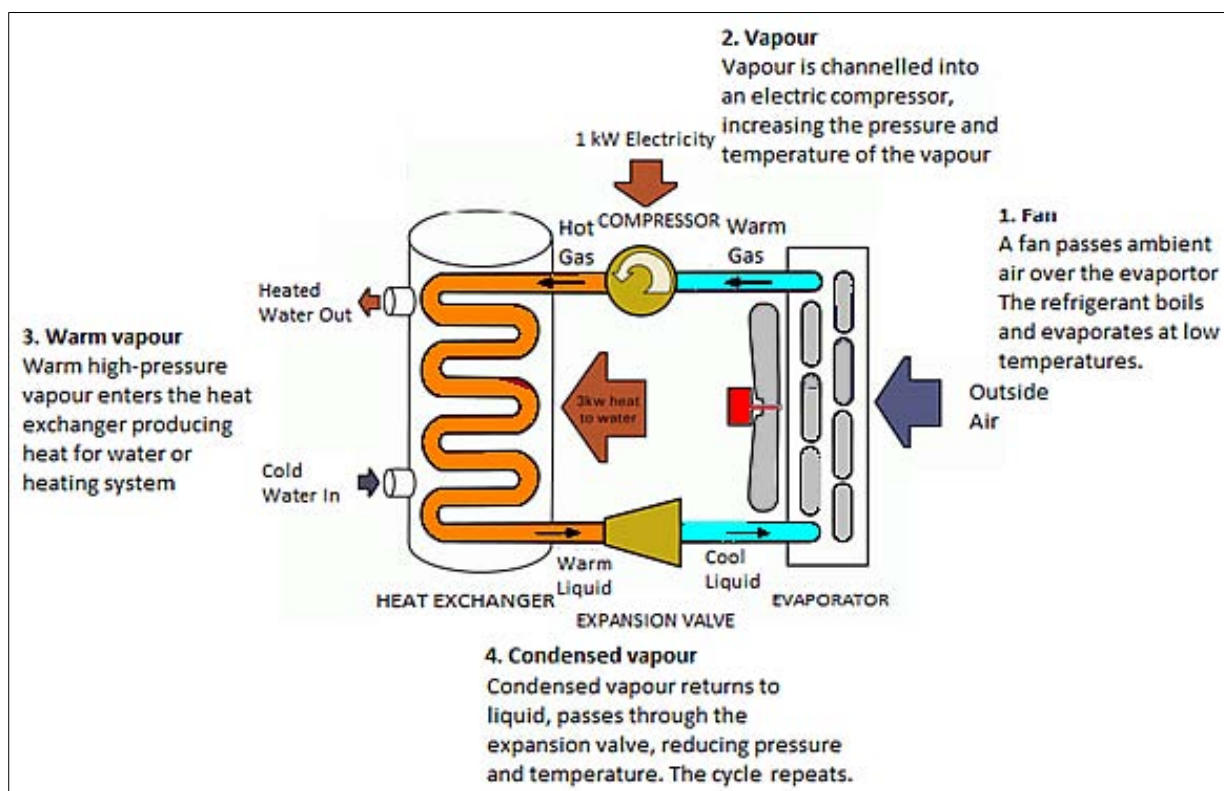


Figure 7.12: Schematic Diagram of Heat Pump

COP is defined as follows:

**For a refrigeration machine:  $COP_{REF} = \frac{\text{Useful refrigeration output}}{\text{Net-work input}}$**

**For a heat pump:  $COP_{HP} = \frac{\text{Useful heat rejected from cycle}}{\text{Net-work input}}$**

### Various applications of heat pump

The primary application of heat pumps is space conditioning in hotels, malls, theatres and other commercial buildings. The system combination of solar thermal collectors and heat pumps is a very attractive option for increasing renewable energy usage for heating and domestic hot water preparation. In industrial applications, they can be used at temperatures from below  $-100^{\circ}\text{C}$  to above  $100^{\circ}\text{C}$ . The heat pumps are available with capacities ranging between 1 kW to 10 MW.

Industrial Applications include the following:

- Dairy, pharmaceutical, textile, food processing and cold stores, automobile, etc.
- Cold utility: air conditioning, process cooling and potable water cooling.
- Hot utility: process heating, boiler feed water preheating, drying, liquid desiccant

### Case Study: Replacement of Electric Heaters with Heat Pump (Figure 7.13)

A. Pre-Heat Pump Situation	
Industrial process	Automotive Components Washing machine
Use of process Heat	Cleaning of gear casings and its components before assembling
End use	Cleaning of oil, dust and the burs from the components
Process Temperature	$50 - 55^{\circ}\text{C}$
Mass flow of the components	80 components(sets) per shift (8 hrs)

### B. System Design

- Primary System – 28 kW Air-Source Heat Pump
- Balance of Plant – Primary and Secondary Circuit (including Buffer Tank and Plate Heat Exchangers)

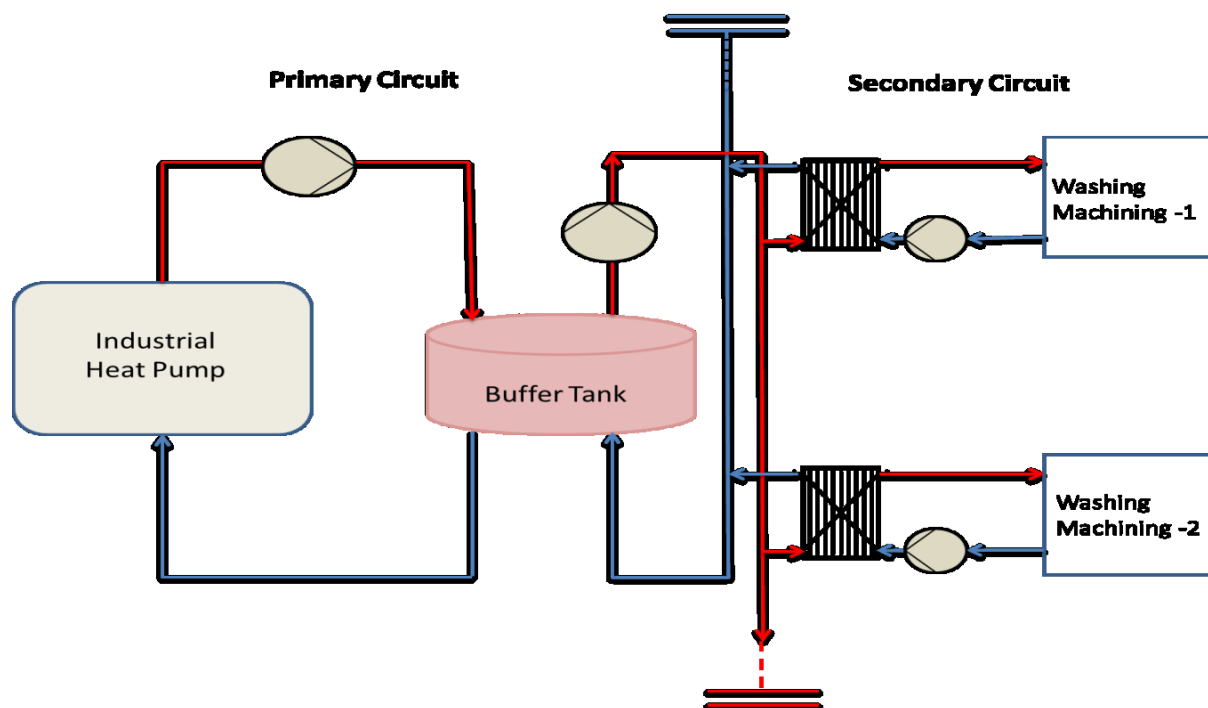


Figure 7.13: Heat Pump Circuit

### C. Results

#### Case I

Description	Before	After
Source of Energy	Electric Heater	Air-Source Heat Pump
Number of Heating Elements	12	1
Capacity of Each Heating Element (kW)	6	28
Total Rated Capacity (kW)	72	28
Electricity Consumption (kWh/year)	1,52,000	72,000
CO <sub>2</sub> Emission (kg/year)	1,24,640	59,040
Total Savings per Year (Rs.)	5,60,000	
Payback Period (months)	23	

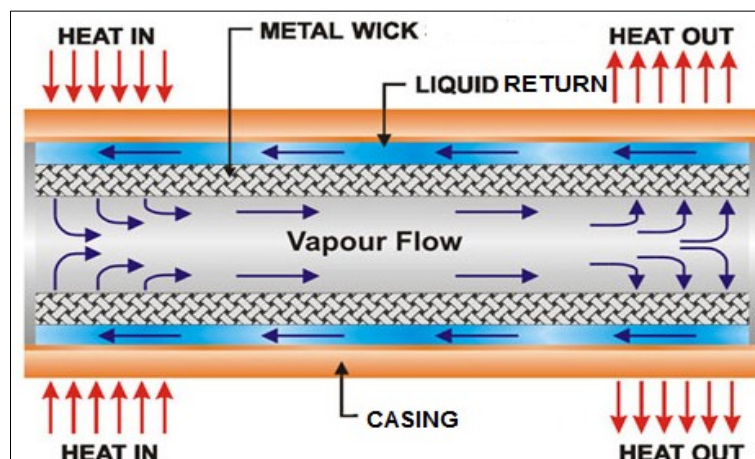
#### Case II

Description	Before	After
Source of Energy	Electrical Heater	Air Source Heat Pump
Total Rated Capacity (kW)	6	14
Electrical Consumption (kWh/year)	32400	13500
CO <sub>2</sub> Emission (kg/year)	26,568	11,070
Total Savings per Year (Rs.)	1,52,000	
Payback Period (Months)	46	

### 7.3.3 Heat Pipe

Heat pipes are devices which can transfer 1000 times more thermal energy than copper. It is used in traditionally difficult heat exchange environments such as high particulate gases, dirty liquids, corrosive environments, low temperature gradients.

Heat pipe is basically a copper tube sealed on both ends with an internal wick or mesh along the interior of the pipe (Figure 7.14). Heat pipe has a working fluid in a vacuum and various fluids used include liquid nitrogen, methanol, water, and sodium. The operating principle of heat pump is based on evaporation/condensing cycle. The working fluid evaporates to vapour absorbing thermal waste heat (heat in). The vapour migrates along the cavity to lower temperature end where it condenses back to fluid, releasing thermal energy (heat out). The working fluid flows back to the high temperature end. Due to continuous cycle of evaporation and condensation large amount of heat is transferred.



**Figure 7.14: Schematic Diagram of Heat Pipe**

The performance (amount of heat that can be transferred) of a heat pipe is a function of its length, diameter, wick structure, and overall shape. The larger the diameter, the more energy it can transport, but longer the length, less capable is the performance.

#### Advantages

- Not affected when any pipe fails
- No cross contamination between hot and cold streams
- No wear and tear
- Complete hot and cold stream separation for heat recovery systems and thus remote heat removal is feasible.
- No additional power needed
- Alternative to rotary regenerator in thermal power plant
- Other applications include control panel cooling, plastic mould cooling, rectifier cooling, oil cooling (pneumatic power packs), gear box oil etc.

### 7.3.4 Condensing boiler

Condensing boiler is a packaged, natural gas fired, condensing steam boiler having almost 100% thermal efficiency on NCV of natural gas. To achieve maximum heat recovery, this packaged boiler consists of six passes of flue gas namely, three passes in Evaporator a single pass in each of Economizer, Non-condensing Water Pre-Heater and Condensing Water Pre-Heater. Combustion products of Natural gas comprise of gases such as Carbon dioxide, Hydrogen Water Vapor, Nitrogen and traces of other inert gases.

Combustion of hydrogen present in the fuel forms water vapour. In addition, moisture/water present in the fuel and moisture in air also evaporate and is carried along with flue gas in vapour form.

In a standard boiler, evaporation of the total water and rise to flue gas temperature requires heat energy or enthalpy, which is taken away from the gross energy released during combustion process. As a result, heat carried away by the water vapour in the flue gas is not available for steam generation and it is directly lost in the atmosphere. The air and the combustion products other than water (CO<sub>2</sub>, CO, NO<sub>x</sub>) and nitrogen also take away some amount of heat.

GCV minus heat carried away in the water vapour, inerts and combustion products per unit mass of the fuel is called Net calorific Value (NCV). Boiler efficiency is calculated based on NCV of the fuel as the heat carried or lost with water vapour is any way not available for heat transfer. It is NCV which is available for heat transfer in the boiler for steam generation.

On the other hand, condensing boilers use heat from exhaust gases that would normally be lost and released into the atmosphere as flue gas. To use this latent heat, the water vapour from the exhaust gas is turned into liquid condensate through heat exchange of cold demineralized feed water which is preheated in a specially designed condensing economizer. Due to this process, a condensing boiler is able to extract more heat from the fuel than a standard boiler, which means that less heat is lost through the flue gases.

Condensing boiler comprises of three passes of heat recovery in a fire-tube type boiler; followed by fourth pass of heat recovery in economizer, fifth pass in non-condensing water preheater and sixth pass in condensing preheater. On flue gas side, the condensing preheater is followed by external structure-supported stack with material of construction, carbon steel with internal FRP lining or Stainless Steel conforming to IS 6533.

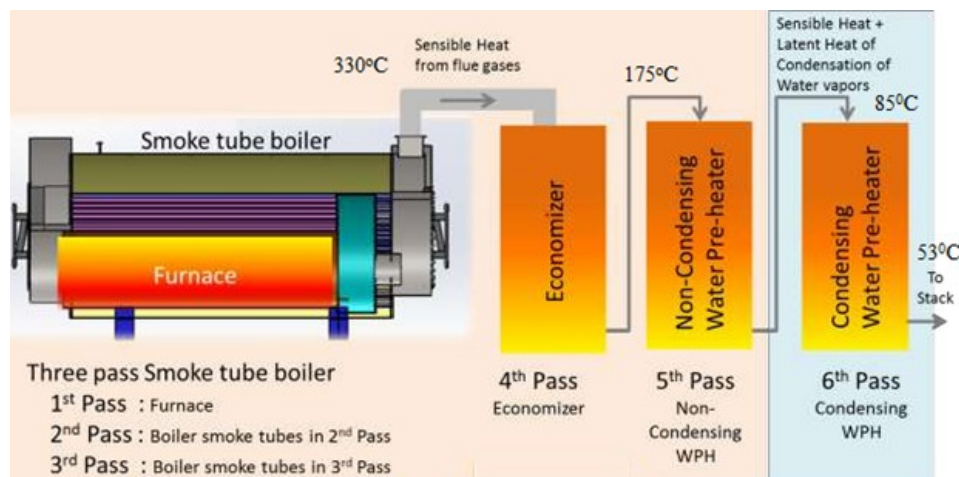
The boiler also has operational flexibility as the same boiler could be operated by through fuel ranging from Natural Gas to FO / LDO / HSD, by bypassing condensing preheater by operating flue gas diverter valve & feed water bypass arrangement.

#### **Case Study-1: Energy savings with installation of condensing boiler**

As seen in Figure 7.15, flue gas temperature exiting the boiler at 330°C is passed through the non-condensing economizer where temperature is reduced to 175°C. The flue gas

enters non-condensing water pre-heater where temperature is reduced to 85°C. Finally it is passed through condensing water pre-heater/economizer where final temperature of the flue gas is further reduced down to 53°C by preheating the boiler feed make up water fed at 31°C. Overall, flue gas temperature is reduced from 330° to 53°C. The benefits:

- Thermal efficiency improved (lower natural gas consumption for unit production of steam).
- Water recovery from the flue gas.



**Figure 7.15: Schematic Diagram of the Condensing Boiler**

Scenario before and after installation of 24 TPH condensing boiler is as follows:

S. No.	Description	Before	After
1	Flue gas Exit Temperature in chimney, °C	115	55
2	Water Recovery from flue gas per annum, (L)	0	60,00,000
3	Natural Gas Consumption per MT of steam, Sm <sup>3</sup>	74	70
4	Natural Gas savings per annum, Sm <sup>3</sup>	0	5,50,000
5	Energy Cost savings per annum, Lakhs	0	200
6	Average reduction in carbon dioxide emission (estimated), MT/annum	0	1600
	Boiler Thermal Efficiency on NCV of fuel, (%)	92	100

Source: Improve boiler efficiency and recover water from flue gas; Syamal Kumar De; Chemical Industry Digest. April 2016

### Case Study-2

A condensing boiler was built in year 2013 for a German-owned pigment processing company having process plant at Gujarat, India. The details of the installation are as follows:

Fuel	Natural Gas
Capacity	24000 kg/hr (F&A 100)
Safety valve set pressure	14.5 kg/cm <sup>2</sup> (g)
Application	Steam for process use
Thermal efficiency on NCV of fuel	100 %
Condensate return quantity. & temperature from process	65% @ 50°C.

The performance trials were conducted by both direct as well as indirect method. The Figure 7.16 accompanied by the table shows the performance of the condensing boiler in terms of overall thermal efficiency versus outlet temperature of the flue gas.

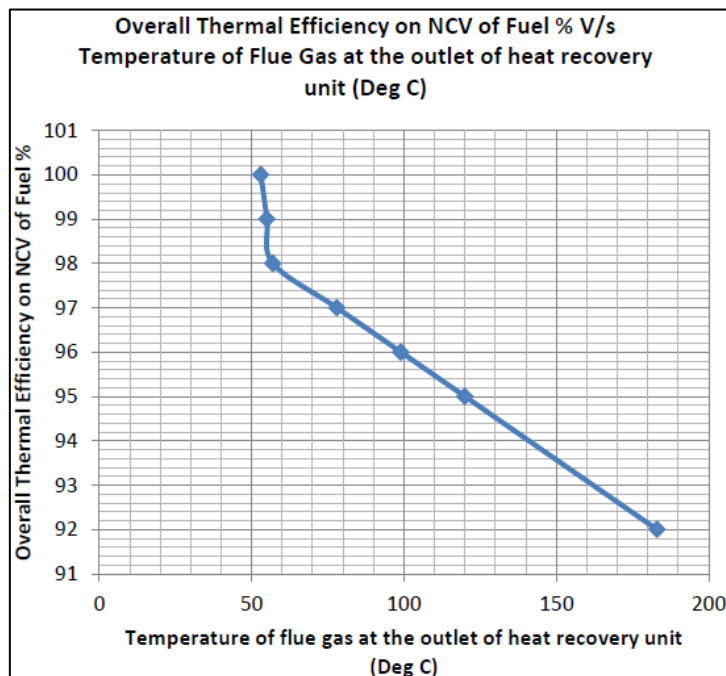


Figure 7.16: Overall Thermal Efficiency vs Temperature of Flue Gas

Temperature of Flue Gas at the Outlet of Heat Recovery Unit ( $^{\circ}\text{C}$ )	Overall Thermal Efficiency, on LHV Basis (%)	Overall Thermal Efficiency, on HHV Basis in %
183	92	83.1
120	95	85.8
99	96	86.7
78	97	87.6
57	98	88.5
55	99	89.4
53	100	90.3
51	101	91.2

Performance test was carried out by Indirect Method as per BS-845-part I

### 7.3.5 Absorption chillers

Absorption chillers use heat as their energy source unlike vapour-compression chillers which use electricity. Typically, the heat is supplied in the form of steam, hot water, direct combustion of Natural Gas or even waste heat. Absorption chillers are either lithium bromide-water ( $\text{LiBr}/\text{H}_2\text{O}$ ) or ammonia-water based equipment. The  $\text{LiBr}/\text{H}_2\text{O}$  system uses lithium bromide as the absorber and water as the refrigerant. The ammonia-water system uses water as the absorber and ammonia as the refrigerant. The absorption chillers will have an advantage over motor-driven vapor-compression chillers, if excess waste heat is available and electricity cost is high.



Single-effect LiBr/H<sub>2</sub>O absorption chillers use low-pressure steam, or hot water with temperatures as low as 90°C as the heat source. The thermal efficiency of single-effect absorption systems is low. A single stage lithium bromide-based absorption chiller produces chilled water at 6-8°C and has a COP of about 0.7.

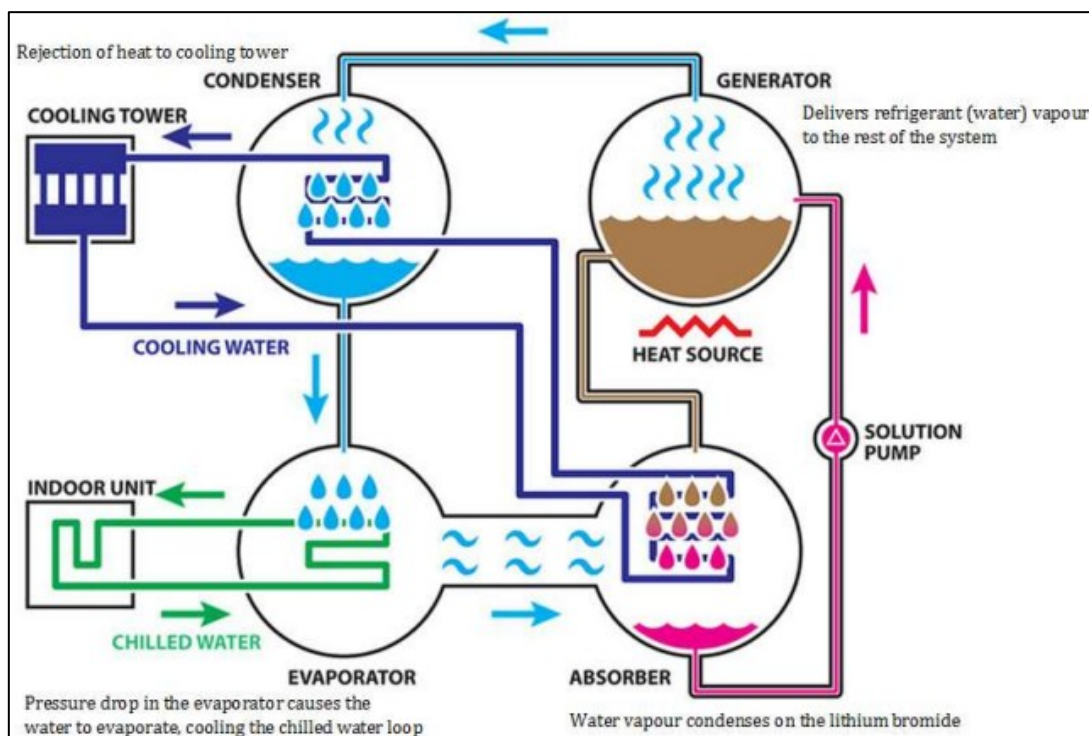
The double-effect chillers need higher temperatures, about 170°C, which means they need high-pressure steam or gas-fired as the heat source. Double-effect absorption chillers are typically used in applications, where excess high-pressure steam is readily available. The COP is about 1.2 which means that they can produce chilling capacity corresponding to 1.2 times the heat source capacity. The COP range for the different absorption chiller types is given in Table 7.3.

**Table 7.3: Typical Chiller Types and Efficiencies**

Absorption Chiller Type	COP Range
Hot water or steam single-effect chiller	0.60-0.75
Hot water or steam double-effect chiller	1.19-1.35
Direct fired double-effect chiller	1.07-1.18

### 7.3.6 Trigereneration

Trigereneration is the simultaneous conversion of fuel energy into three useful energy products: electricity, hot water or steam and chilled water (Figure 7.17). A trigereneration is acutally a cogeneration system with an addition of absorption chiller that uses some of the heat to produce chilled water. Unlike vapour compression chillers using electricity, trigereneration uses recovered heat from both the exhaust gas and engine cooling circuit.



**Figure 7.17: Trigereneration**

### Trigeneration application

A trigeneration plant was set up at a government hospital in New Delhi, India. The plant has three major components (Figure 7.18), a gas engine, a Vapour Absorption Machine (VAM) and an electrical chiller (vapour compression) for meeting balance cooling demand. The details of Trigeneration plant are as follows:

Equipment	Make	Size
Gas Engine	Schmitt Enertec	347 kW, natural gas fuel
VAM	Thermax	105 TR, COP 0.7
Chiller	York	250 TR, COP 4.0
Cooling Tower	Paharpur	1800 kW

The system utilizes natural gas as fuel for the gas engine. The engine generates electrical power (347 kW) by utilizing 96 standard cubic meter (scm) gas per hour and the exhaust gas at 400°C is passed through the VAM. The VAM through absorption refrigeration cycle produces chilled water at 7°C by utilizing heat from the high-temperature exhaust gases, further increasing the efficiency. Heat from the low temperature circuit is used to pre-heat the water being fed into the boiler further increasing the efficiency. Thus the overall efficiency of the system increases up to 67% as against 36%.

The energy savings from the Trigeneration plant is around 660,000 kWh per annum. The reduction in CO<sub>2</sub> emission is 1700 tCO<sub>2</sub> per annum as the result of utilization of waste heat in VAM.

Particulars	Value (million Rs)
Equipment cost	350
Additional project cost	62
Total project investment	412
Annual savings from Trigen	130
Project payback	3.2 years

Source: Factsheet, Indo-German Energy Program (IGEN),  
Deutsche Gesellschaft für Internationale Zusammenarbeit (GIZ)

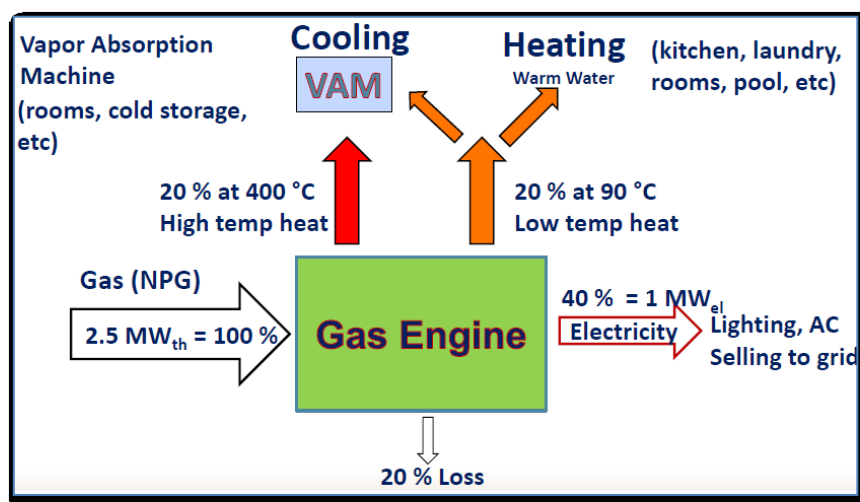


Figure 7.18: Trigeneration Application

### 7.3.7 Organic Rankine Cycle (ORC)

ORC is a power generation plant which on a mini-scale is in the range of 10–250 kW. Unlike the traditional power plant where working fluid is water, evaporated gas is steam, and engine is steam turbine, the ORC system uses organic fluids which boil at much lower temperatures and pressures than water. Typical organic fluids used include R234fa, R134, pentane, cyclopentane, n-heptane, hexane, and toluene. The ORC systems can even work on low temperature heat sources (90–300°C) for heat recovery.

The schematic of ORC system is shown in Figure 7.18. The ORC system is based on the principle whereby organic fluid is heated causing it to evaporate, and the resulting gas is used to turn an organic vapour turbine (expander) which is coupled to a generator producing power. The exhaust vapour is condensed in water or air-cooled condenser and is recycled to the vaporiser by a liquid pump.

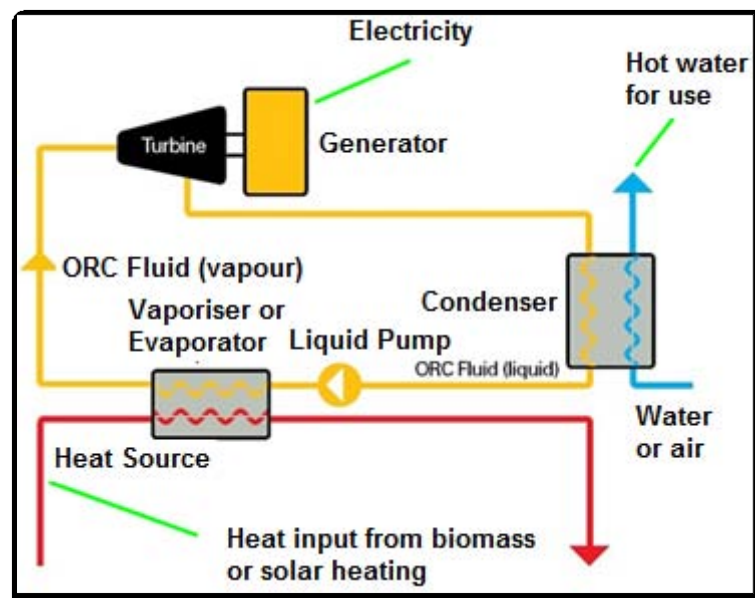
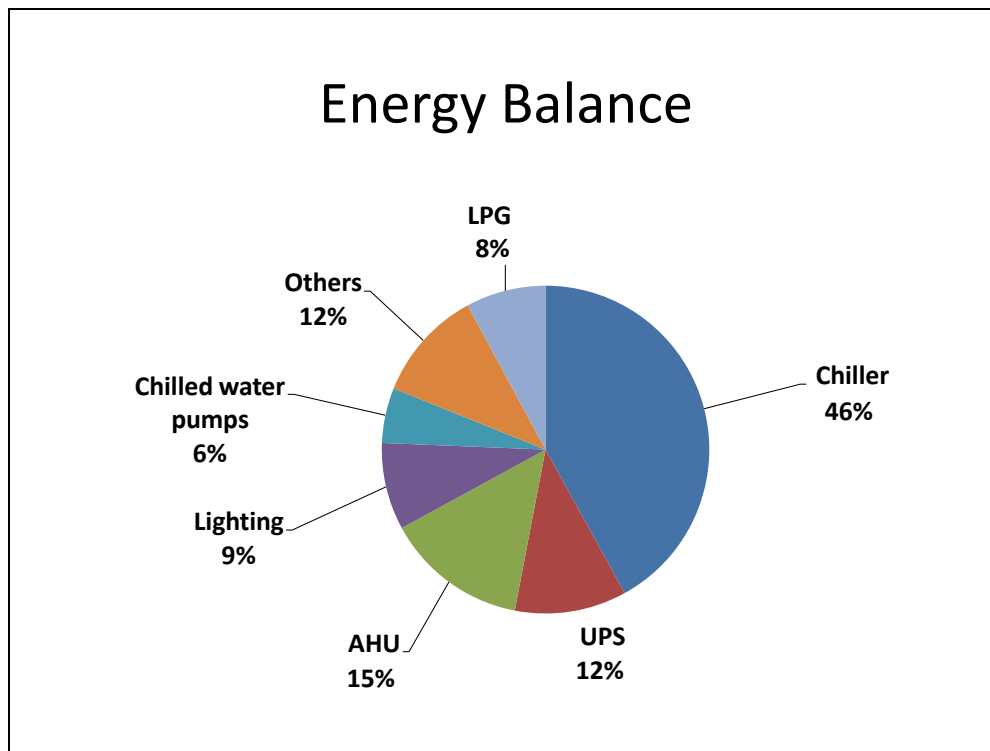


Figure 7.19: ORC Process Schematic

## 8. BEST PRACTICES IN BUILDING ENERGY MANAGEMENT AND CONSERVATION

### 8.1 Introduction

The construction industry in the country is growing at a rapid pace because of large-scale urbanization and increasing income, and the rate of growth in India is 10% as compared to the world average of 5.2%. It is being projected by 2030 that two-thirds of the buildings have yet to be built and 1 billion m<sup>2</sup> of new commercial buildings will be added. Commercial buildings are the third largest consumers of energy, after industry and agriculture. Buildings annually consume about 30–35% of electricity consumption in India. Break-up of energy consumption break up in a typical office building in an IT park building is shown in Figure 8.1



**Figure 8.1: Energy Consumption in an Information Technology Park Building**

Out of the total electricity consumed in the building sector, around 75% is used in residential buildings. The production of residential building stock is quickly shifting from building individual homes and low rise buildings to multistory residential buildings. This form of housing will be in the formal sector and subject to the building byelaws and urban development regulations of the Local Urban Bodies (ULBs).

The gross electricity consumption in residential buildings has been rising sharply – it was around 50 TWh in 1995 and has increased by more than four times in next 20 years and was around 220 TWh in 2015. Projections show it will rise to about 600-900 TWh by 2030. The

major reason to this rapid rise in the electricity use in residential buildings is attributed to the increased use of decentralized room based air conditioning units in homes.

The potential for energy savings is 40–50% in buildings, if energy efficiency measures are incorporated at the design stage. For existing buildings, the potential for energy savings that can be achieved by implementing best O&M practices and retrofitting measures is 20–25%.

## 8.2 Green Building

The energy, water and materials demands for buildings have been growing enormously over the years and the need has arisen to minimize natural resource consumption in building and associated impact on the environment. Buildings are responsible for 40% of global emissions and 60% of the wastes globally.

Green Buildings (also known as green construction or sustainable buildings) offer some of the most effective means to achieving a range of global goals, such as addressing climate change, creating sustainable and thriving communities, and driving economic growth. The goal is to convert buildings to energy neutral structures.

*"A green building is one which uses less water, improves energy efficiency, conserves natural resources, generates less waste and provides healthier spaces for occupants, as compared to a conventional building".*

Green buildings can play a catalytic role in addressing environmental issues and concerns. A green building incorporates the following features:

- Energy efficiency
- Water efficiency
- Better living conditions
- Eco-friendly sustainable materials
- Less transport use
- Less waste
- Habitat protection/restoration.

Green buildings offer a number of economic benefits as well. These include cost savings on utility bills for tenants or owners through energy and water efficiency; lower construction costs and higher property value for building developers; increased occupancy rates, lower operating costs for building owners; job creation, health and well-being of occupants. A sample list of green building features is shown in Table 8.1.

**Table 8.1 List of Green Building Features**

<b>Building Design</b>	Orient building to allow optimum sunlight and ventilation
<b>Envelope</b>	High performance walls, roofs <ul style="list-style-type: none"> <li>○ <i>Fly ash bricks for walls, over deck insulation, etc.</i></li> </ul>
<b>Glass</b>	High performance glass – Low-E Glass, double glazed units, triple-glazed units.
<b>Appliances</b>	BEE star rated equipment and appliances <ul style="list-style-type: none"> <li>○ <i>Air conditioners, refrigerators, Geysers, etc.</i></li> </ul>
<b>Lighting Systems</b>	Energy efficient lamps and luminaries <ul style="list-style-type: none"> <li>○ <i>T5, CFL, LED, High frequency electronic ballast etc.</i></li> </ul>
<b>Renewable energy sources</b>	Solar photovoltaic, solar water heaters, biogas etc.
<b>Energy Monitoring</b>	Energy meters & sub meters to measure, monitor & sustain building performance.
<b>Water Fixtures</b>	Use ultra low & low flow & flush water fixtures <ul style="list-style-type: none"> <li>○ <i>Dual flush systems, (high flush 4 – 6 LPF / low flush 1.5 - 2 LPF), water less urinals etc.</i></li> </ul>
<b>Water Management</b>	<ul style="list-style-type: none"> <li>● Provide rain water harvesting / storage structures</li> <li>● Treat 100% of waste water onsite</li> <li>● Use water meters to monitor the consumption of treated grey water, irrigation water, rainwater reuse, domestic hot water etc.</li> </ul>
<b>Sourcing of Building Materials</b>	Use eco-friendly building materials and try to source materials that are locally manufactured (within 400 km) from project site
<b>Certified Wood</b>	<ul style="list-style-type: none"> <li>● Use wood certified by local forestry or rapidly renewable materials (plantations which can completely replenish within 10 years) for all wooden products &amp; furniture.</li> </ul>
<b>Sustainable Site measures</b>	<ul style="list-style-type: none"> <li>● Retain fertile top soil excavated during construction for landscaping during post-occupancy</li> <li>● Maximise the vegetated open space in the building</li> </ul>
<b>Transportation</b>	<ul style="list-style-type: none"> <li>● Use alternate fuel vehicles such as electric cars for local conveyance and encourage car/van pooling and public transport</li> </ul>
<b>Landscaping</b>	<ul style="list-style-type: none"> <li>● Reuse treated waste water for landscaping</li> <li>● Use drought tolerant and native species for landscape to reduce irrigation requirement (Xeriscaping)</li> </ul>
<b>Irrigation efficiency</b>	<ul style="list-style-type: none"> <li>● Use drip and sprinkler irrigation systems for enhanced water efficiency</li> </ul>
<b>Interior Finishing Materials</b>	<ul style="list-style-type: none"> <li>● Use NO or low VOC (Volatile Organic Compound) materials such as paints, adhesives, sealants, coatings etc.</li> </ul>
<b>Ventilation &amp; day lighting</b>	<ul style="list-style-type: none"> <li>● Design openings to enhance cross ventilation</li> <li>● Ensure maximum daylight into all occupied spaces</li> </ul>
<b>Views for occupants</b>	Design interior layouts which would provide a better connectivity to the occupants with the external world

The various green building rating systems are BEE Star Ratings for buildings, GRIHA, IGBC and USGBC based-LEED certifications. All of these use Energy Conservation Building Code (ECBC) 2017 as the baseline requirement to evaluate energy consumption of building.

### **IGBC Green Building Rating Systems**

IGBC Green Building Rating Systems have been developed by the Indian Green Building Council (IGBC) to suit the national context and priorities. The Rating System incorporates National Standards and Codes namely National Building Code (NBC), Energy Conservation Building Code (ECBC), Ministry of Environment & Forests (MoEF) and Central Pollution Control Board (CPCB) guidelines.

National priorities addressed in this rating system include water conservation, waste management, energy efficiency, reduced use of fossil fuels and lesser dependence on usage of virgin materials. Different rating systems are developed for different building types: commercial, residential, cities, townships, schools, healthcare, data centres and several others.

### **Green Rating for Integrated Habitat Assessment (GRIHA)**

Green Rating for Integrated Habitat Assessment (GRIHA) is the rating system jointly developed by TERI and the Ministry of New and Renewable Energy, Government of India. GRIHA is aimed at using best of traditional architecture and modern technology to build new buildings. The latest version of GRIHA is called GRIHA V – 2015. Buildings would be rated on a 1-5 star scale, with 5 star labeled buildings being the most efficient. GRIHA rating system consists of 31 criteria and points are assigned to different criteria which reflect current resource priorities of India.

### **USGBC-LEED**

LEED, which is Leadership in Energy and Environmental Design, is a third party certification for design, construction and operation of a given building. US Green Building Council (USGBC) has completed a comprehensive update of LEED which is called LEED v4. Seven impact categories considered under LEED are as follows:

- Reverse contributing to global climatic change
- Enhance individual human health and well-being
- Protect and restore water resources
- Protect, enhance and restore biodiversity and ecosystem resources
- Promote sustainable and regenerative resource cycles
- Built a greener economy
- Enhance social equality, environmental justice, and community quality of life.

### **Other International Rating Schemes**

Other international rating schemes include US Environmental Protection Agency (USEPA) energy star and National Australian Built Environment Rating System (NABERS). USEPA energy star for buildings is more popular internationally and accounts for data centers and labs. NABERS is specific to Australia and is designed taking into account density of

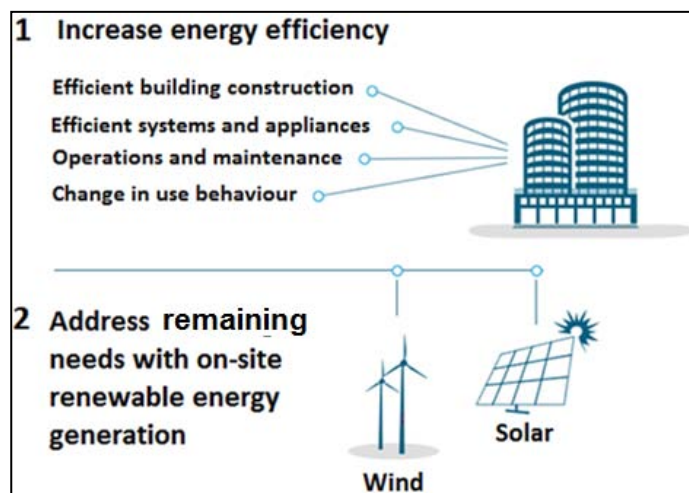
workspace. The number of employees working in the main shift, number of workstations, efficiencies of the UPS and allied systems to ensure uninterrupted power supply to IT equipment and the server rooms influence the energy performance and need.

### 8.3 Net Zero Energy Building (NZEB)

Net or nearly zero-energy buildings (NZEB) have very high performance. The low amount of energy that these buildings require comes mostly from renewable sources. Such buildings produce as much energy as they consume, accounted for annually.

In order to achieve their net zero energy goals, NZEBs must first reduce energy demand using energy efficient technologies, and then utilize renewable energy sources to meet the residual energy demand (Figure 8.2). In such buildings, efficiency gains enable the balance of energy needs to be met by renewable energy technologies.

NZEB is aimed at eliminating greenhouse gas (GHG) emissions associated with the operation of new buildings by 2030, and eliminate the GHG emissions from all buildings by 2050. Meeting NZEB objectives will require addressing both active and passive measures along with energy generation/supply from renewable energy such as Solar Photovoltaic, Winds, Biogas, and any other applicable hybrid renewable energy system. Achieving zero energy is an ambitious, yet increasingly achievable goal



**Figure 8.2: NZEB Concept**

### 8.4 Building as an Energy System

Modern buildings are complex structures; there are significant interactions among the various systems of which they are comprised. The energy auditor needs to look holistically at the building when recommending efficiency measures to ensure that these energy interactions are taken into account. Among the interactions that need to be considered are the following:

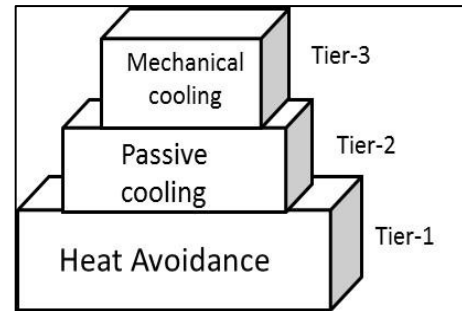
A lighting retrofit from incandescent to LED lighting, because of the improved efficiency, will reduce the internal heat gain of the building; therefore, in the cooling season, the cooling system will experience a decreased load. Because the AC system not only cools, but dehumidifies the building, the same lighting retrofit could result in an over-designed cooling



plant to operate less frequently to maintain temperature, thereby causing humidity to increase.

Building envelope improvements such as increased insulation and reduced infiltration will have similar effects as noted on cooling plant. The reduced infiltration could require an increase in fresh air supply (thereby fan energy) in order to maintain occupant comfort and meet indoor air quality standards.

In case of strategies such as using passive methods for cooling, the most sustainable approach would be adopting three-tier approach with heat avoidance being the first preference, followed by passive cooling, and mechanical cooling as shown in Figure 8.3.



**Figure 8.3: Sustainable Cooling Strategy**

## 8.5 Energy Saving Approaches for Building

Some of the key energy efficiency measures covering building envelope (Walls, Roofs, Windows), Heating Ventilation and Air Conditioning (HVAC) system, Lighting (indoor and outdoor), and Electrical Power and Motors are briefly described as follows:

### 8.5.1 Passive Designs

Passive designs take advantage of local climates and reduce energy consumption for heating or cooling the building by optimising insulation, ventilation, orientation, and shade of a building.

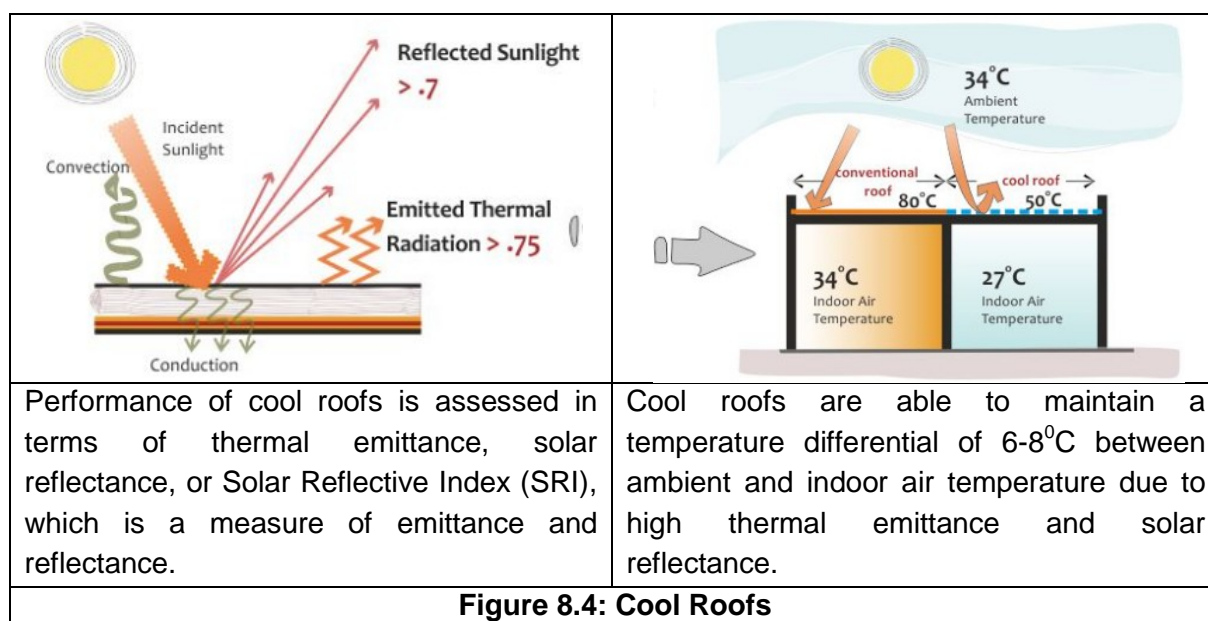
#### Form and Orientation

This is the first step to achieve energy efficiency. In predominantly hot regions, buildings should be ideally oriented to minimize solar gains in summer and maximize solar gain in winter. Proper building layouts also ensure redistribution of air and provide shade. A rectangular building footprint stretched from east to west helps minimise direct sun from angles where it is difficult to control. It also helps to shade exterior courtyards, reducing the amount of southern exposure. This orientation also directs night time breezes and day time sea breezes (if located on coast) to cool outdoor spaces. Usable area can be increased through shading and ventilation of outdoor spaces. The following measures are recommended:

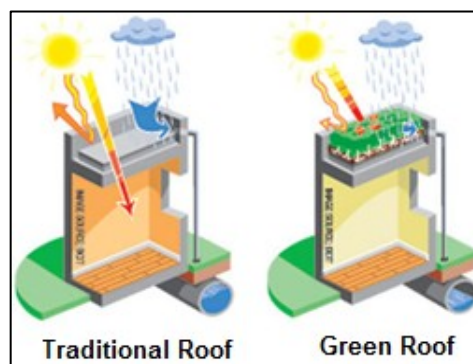
- Orient longer facades along the north. This will allow glare free light in summer from north without shading and winter sun penetration from the south.
- Make building shape compact to reduce heat gain and losses.
- Use simulation tools and techniques to design orientation to minimize heat ingress and enhance energy efficiency.

## Minimising heat gain through roofs

**Cool roofs:** Conventional roofs are the worst possible summer design. Instead of acting like a shade for occupants in the building, they create unbearable heat. Cool roofs use solar-reflective surfaces (e.g. Galvalum) to maintain lower roof temperatures (Figure 8.4). Highly reflective and light-colored roofs decrease the amount of heat that is absorbed from direct sun, thereby reducing cooling energy. Such roofs achieve the greatest cooling energy savings in hot climates, but can increase energy costs in colder climates. Materials that are light in colour are not the only factor, but also chemistry of coatings. Specialized paints are available to increase the reflectance of existing buildings. Low-rise buildings with large roof areas are ideal candidates for such applications.



**Green roofs:** Green roofs and walls enhance thermal mass, provide evaporative cooling, insulative performances, prevent solar heat from entering the building, and keep the local air temperature around the building cooler thereby reducing air conditioning energy (Figure 8.5). They also improve building acoustics. ‘Intensive’ green roofs have deeper soil, larger plants and can be used as rooftop gardens, but are very heavy. ‘Extensive’ green roofs have shallow soil, ground-covering plants, and are lighter.

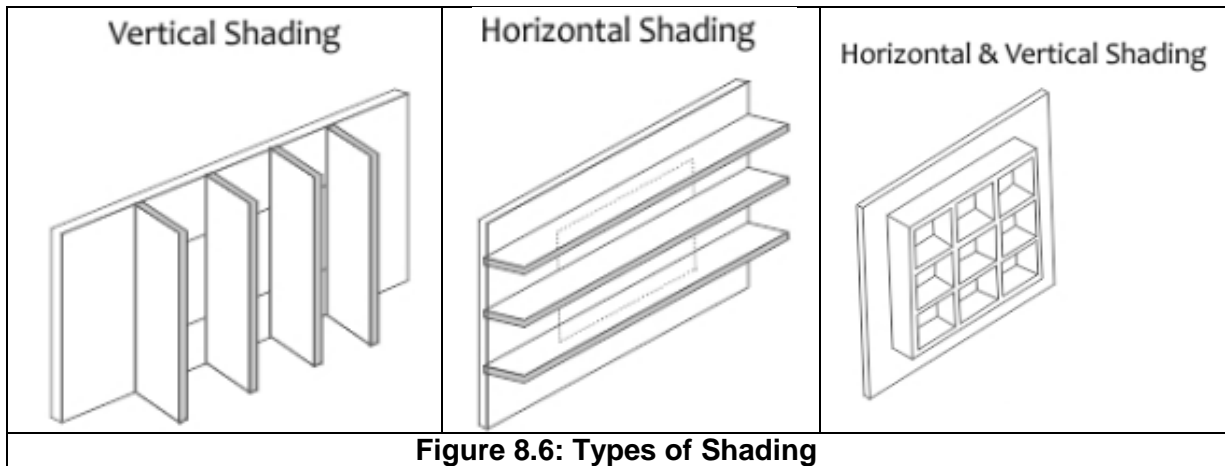


**Figure: 8.5: Green Roofs**

**External shading:** External shading can be used to exclude direct sun before it reaches a building’s windows and control glare. Various types of shading are illustrated in Figure 8.6.

Overhangs on south-oriented windows provide effective shading by blocking summer sun and admitting winter sun. On south-facing glass, a fixed horizontal overhang is suggested.

Horizontal shading are the best type of 'fixed' (non-movable) shading for facades facing North (and South, for northern locations); vertical shading are best for east and west. If no exterior shading is possible, adopt lower solar heat gain coefficient for glazing. On east and west glass, window area should be minimized as they are difficult to shade.



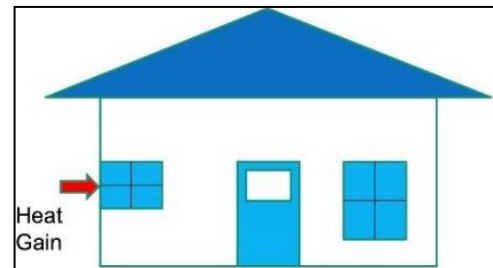
**Figure 8.6: Types of Shading**

Landscaping can be considered to shade east and west exposures. 'Vegetation can be used as shading, as appropriate for the climate zone.

### Fenestration

Fenestrations (windows, skylights, & other openings in a building etc.) allow daylight and the prevailing wind inside the building when needed (Figure 8.7). Building fenestrations can affect lighting and cooling loads considerably. Various methods to reduce heat gain through windows include the following:

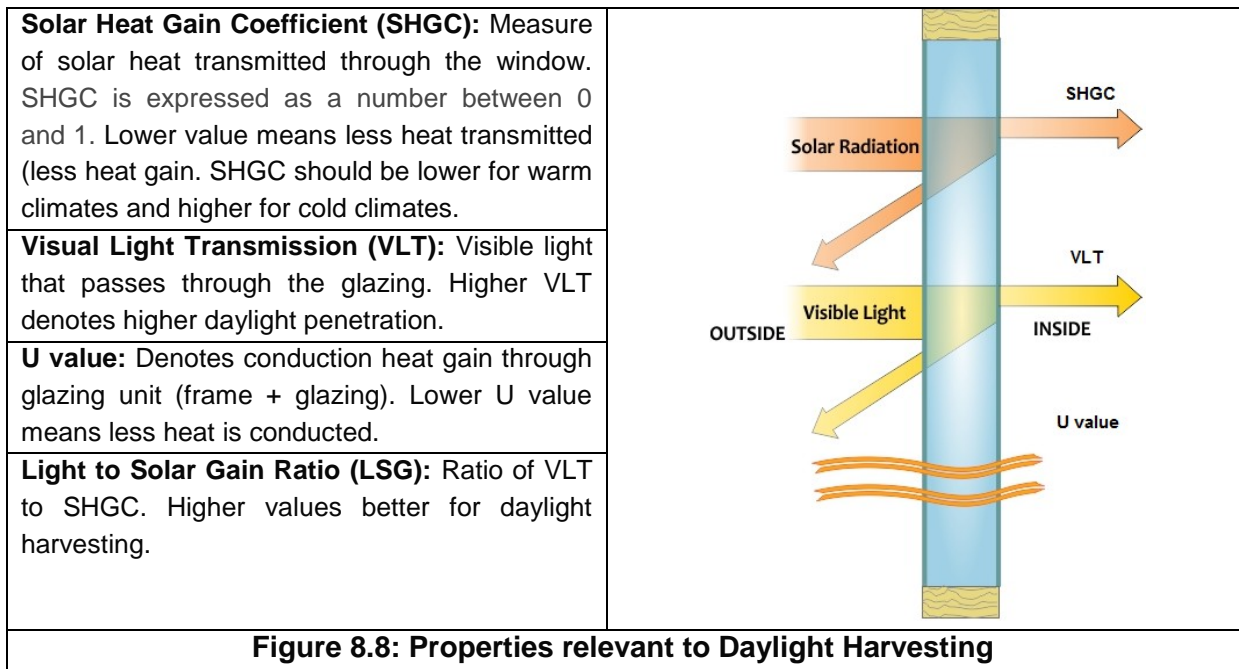
- Orientation and size
- Glazing
- Internal shading devices (blinds, curtains)
- External shading devices



**Figure 8.7: Fenestration**

Fenestrations also influence daylight harvesting potential by reducing lighting loads without compromising on visual and thermal comfort of building occupants.

The properties relevant to daylight harvesting and energy efficiency are illustrated in Figure 8.8.



The following options are to be considered:

- Reduce glazing area as long as it does not affect the uniformity of daylight distribution in a building.
- Reduce Solar Heat Gain Coefficient (SHGC) as less heat will be transferred into the building.
- Adopt glazing with low U value as well as low SHGC, except for the cold climate where high SHGC is recommended.

**Effective building material sealing:** Air leakage can be minimized by adopting caulking, gaskets, and weather stripping the following vulnerable areas:

- Openings between walls and foundations and between walls and roof and wall panels
- Openings at penetrations of utility services through, roofs, walls, and floors
- Joints around fenestration and door frames
- Site-built fenestration and doors,
- Building assemblies used as ducts or plenums, and
- Any other openings in the building envelope.

**High performance glass:** High performance glass allows daylight in regularly occupied zones and also reduces heat gains thereby reducing air-conditioning capacity. In recent Green Buildings, Solar Heat Gain Coefficient (SHGC) is found to vary between 0.25 (for ECBC code compliance in case of prescriptive approach) to 0.35 in case of whole building performance simulation. Window glasses can be placed so as to have better visual connectivity with outdoor environment and improve occupant productivity.

**Windows with low solar heat gain coefficient (SHGC):** Tinted glass is commonly used to achieve solar control, but has effect of reducing natural daylight. Soft-coat low-E coatings provide the best possible solar control for only a slight reduction in daylight. Reflective and toned glass treatments are other approaches for controlled daylight as well as solar gain.

**Low-E Glass:** Uncoated single-glazed windows are considered to be the weakest thermal component in the building envelope, transmitting large amounts of heat into and out of a building. 'Standard clear glass has an emittance of 0.84 over the long-wave portion of the spectrum, meaning that it emits 84% of the energy possible for an object at its temperature. It also means that 84% of the long-wave radiation striking the surface of the glass is absorbed and only 16% is reflected.

By comparison, low-E glass coatings can have an emittance as low as 0.04 which means such glazing would emit only 4% of the energy possible at its temperature, and thus reflect 96% of the incident long-wave, infrared radiation. Soft-coat low-E' glass coatings on clear glass provide the best possible daylight transmission (measured as 'VLT') while achieving good solar control. Low-E glass is comprised of extremely thin layers of silver or other low emissivity materials. The silver low-E coating reflects the interior temperatures back inside, keeping the room warm or cold.

**Double-glazed units:** A double-glazed window has two panes of glass with a sealed air gap between them (Figure 8.9). The spacing of the glass panels is usually between 6-20 mm. Double-glazed units ('DGUs') perform better than single-glazing, and filling the cavity with lower conductivity argon gas improves their effectiveness further.

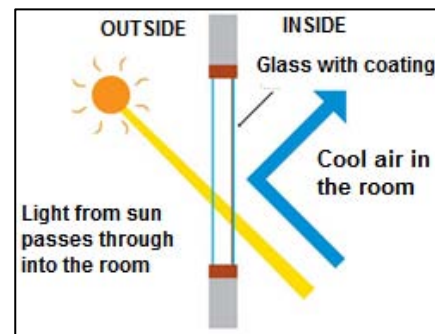


Figure 8.9: DGU with Low-E-Coating

'Low-E' coatings can improve both single and double glazing, with liquid-applied coatings available for pre-existing windows. The window framing system also has a major influence—one large pane performs better than many small panes. In comparison with single glazing, double glazing reduces heat conduction by about 50%

**Triple-glazed units:** The best insulation performance that can be achieved for windows with the above approaches is generally around a system U-value of 2.5 W/m<sup>2</sup>·K. Triple-glazing offers further improvements, and filling the two cavities with inert gases like argon improves their effectiveness (Figure 8.10). Triple glazing, which is becoming common in some European countries, reduces heat conduction by about 30% (relative to double glazing).

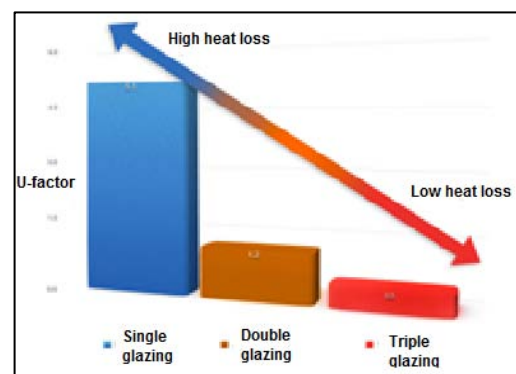


Figure 8.10: Heat Loss Comparison

**Thermochromic and Electrochromic Glass:** Thermochromic glass becomes darker when it is heated up by direct sun and clearer again when it cools down. This improves natural daylight when the glass is not in direct sun, and limits solar heat gains (reducing cooling energy) and glare when it is.

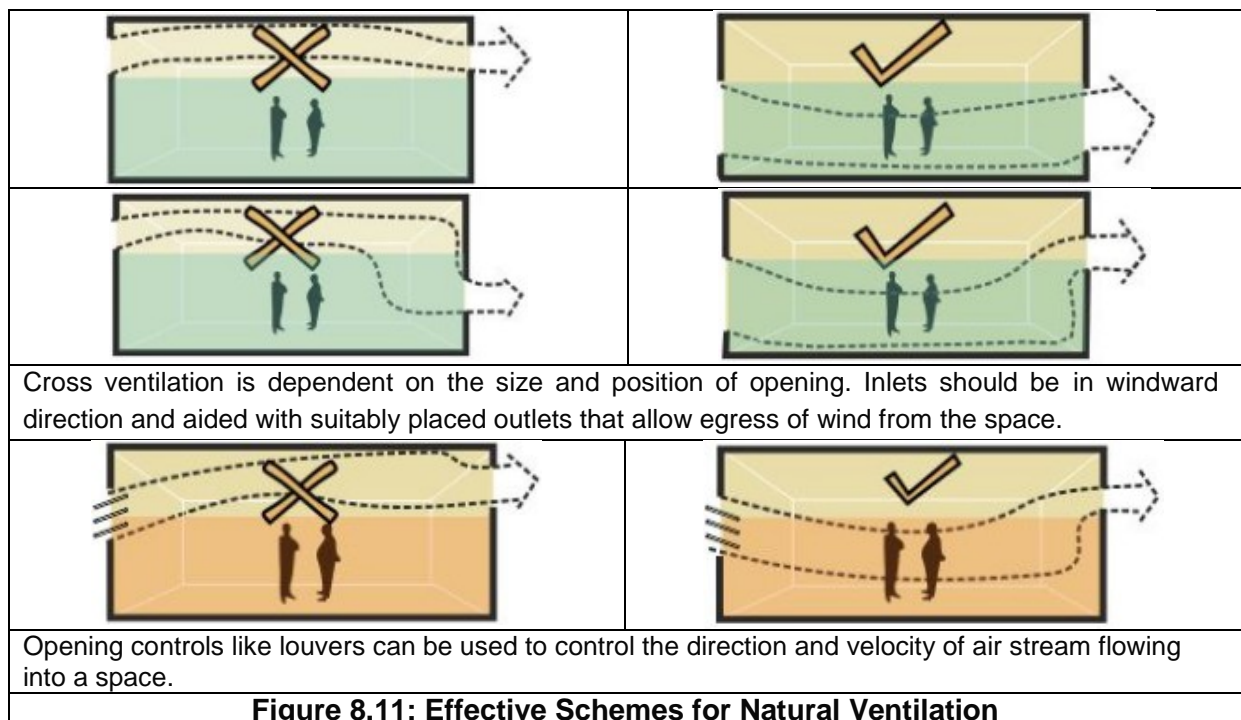
Electrochromic glass also changes from clear to dark, but that change is instead triggered by an applied electric voltage (typically controlled by a local switch or a building management system), which provides choice over whether to allow or exclude solar heat gains.

**Double skin facades:** Double skin facades involve a secondary line of glass outside of the main glass facade. They allow the introduction of movable external shading on high rise buildings, which enables very clear glass to be used (improving natural daylight) and enhanced solar control (reducing cooling energy). Double skin facades generally have a better overall insulative performance, and can be designed to deliver effective natural ventilation in high rise buildings. They can be ventilated or sealed, and the distance between the glasses can be wide or narrow. When narrow and sealed they are called Closed Cavity Facades (CCF).

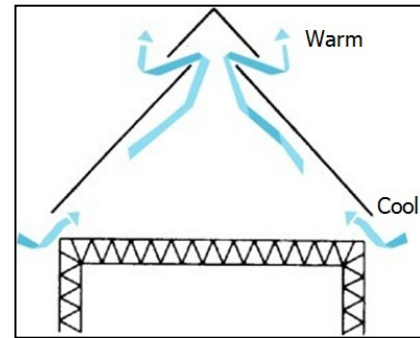
### Low energy cooling

**Natural ventilation:** Ventilative cooling uses the principle of exhausting the warm building air and replacing with cool outside air. Well-directed moving air across occupant's skin creates convection and evaporation. This principle is achieved by wind and stack effect. Suitable openings are not only provided, but located correctly and are large enough for this principle to work properly. Various schemes for natural ventilation are shown in Figure 8.11.

For effective natural ventilation, building openings should be in opposite pressure zone (since natural ventilation relies on pressure to move fresh air through buildings).



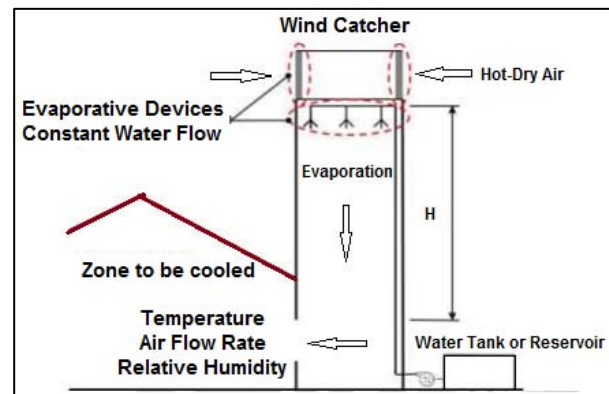
**Stack-Effect ventilation:** A stack-effect ventilator also called as solar chimney uses passive solar heat as the driving force. The principle is illustrated in Figure 8.12. The warm indoor air is lighter and has more buoyancy than cooler air. The temperature differential induces a forced upward flow. As indoor air is evacuated, (cooler) outdoor air flows into the building. The solar chimney is used to exhaust hot air from the building quickly, thus improving the cooling potential of incoming air from openings.



**Figure 8.12: Stack Effect Ventilation**

Solar chimneys having a relatively low construction cost, can move air without the need for the expensive conventional forms of energy, and can cool the building structure at night. They can also improve the comfort of the inhabitants during the day if they are combined with an evaporative-cooling device. This system is especially suitable for large hall-like spaces.

**Passive downdraft evaporative cooling (PDEC):** Passive downdraft evaporative cooling systems (Figure 8.13) consist of a downdraft tower with wetted cellulose pads at the top of the tower. Water is distributed on the top of the pads, collected at the bottom into a sump and re-circulated by a pump. Certain designs exclude the re-circulation pump and use the pressure in the supply water line to periodically surge water over the pads, eliminating the requirement for any electrical energy input. In some designs, water is sprayed using nozzles in place of pads.



**Figure 8.13: Passive Downdraft Evaporative Cooling**

These towers are often described as reverse chimneys. Unlike rise of warm air in conventional chimney, cool column of air falls in PDEC. The air flow rate depends on the efficiency of the evaporative cooling device, tower height and cross section, as well as the resistance to air flow in the cooling device, tower and structure (if any) into which it discharges. In Torrent Research Centre in Ahmedabad, where this system is deployed, the inside temperatures of 29–30 °C were recorded when corresponding outside temperatures were 43–44 °C.

### Thermal insulation

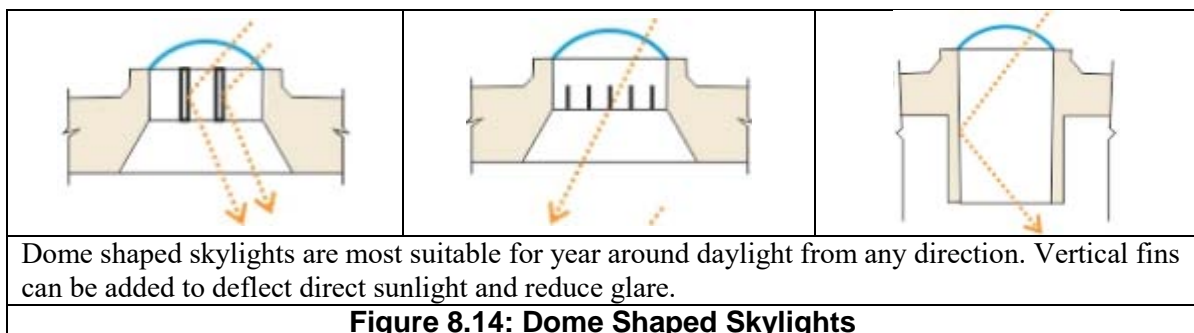
Thermal insulation in walls and roofs reduces heat transfer between the inside and outside and helps maintain comfortable indoor temperature. Insulation keeps indoor space cooler in summer months and warm during winters.

The various materials being used include fibre glass, mineral wool, rock wool, expanded or extruded polystyrene, cellulose, urethane or phenolic foam boards and cotton. They are generally in the form of amorphous wool or rigid sheets, or require in-situ pouring. Insulation is rated in terms of R-value. Higher R-values denote better insulation and saves more energy savings. However, Insulation beyond 100 mm thickness does not offer further benefit in terms of energy efficiency.

Most of the new buildings are designed to have new construction practices for wall insulation such as, *Autoclaved Aerated Concrete (AAC)* blocks, and insulation blocks with *Expanded polystyrene (EPS)* or *Extruded polystyrene (XPS)* type of insulation. These envelope options support in designing new buildings with optimized heat gain, for lesser capacity of air-conditioning equipment thereby reducing cost of operation.

## Lighting

**Daylighting::** Day lighting is the controlled admission of natural light, direct sunlight, and diffused-skylight into a building to reduce electric lighting and saving energy. Appropriate use of windows, skylights, and other apertures in the building helps to harvest daylight. The various methods include external light shelves, light pipes (for large window area), skylights and roof monitors (for areas without access to windows), light coloured interior surfaces which reduces luminance contrast and improves coverage. Large buildings can allow daylight into more spaces by having central courtyards or atria, or having other cut-outs in the building form as illustrated in Figure 8.14.



**Light Shelves:** A light shelf is a passive architectural device used to reflect natural daylight into a building. Unlike direct sunlight which can cause glare near an opening and leaving dark spaces further inside the room, light shelf bounces sunlight off a horizontal surface and distributes it more evenly and deeply within a space. They are often designed as part of a broader daylight and shading strategy.

Light shelves can be fixed either externally or internally. Exterior light shelves can be more



**Figure 8.15 Internal Light Shelf**



effective than internal light shelves as they do not radiate as much heat into the space and so can reduce solar heat gain and cooling loads as well. However, internal light shelves are easier to maintain as they can be more accessible and less exposed (Figure 8.15). Overall light shelves provide following benefits:

- Enhance daylight quality.
- Reduce the need for artificial lighting and hence reduce energy consumption.
- Reduce cooling loads.
- Increase occupant comfort and productivity.
- Enhance design aesthetics.

### 8.5.2 HVAC

HVAC systems contribute to nearly 40% of the energy used by commercial buildings and over 50% of total energy consumption in IT buildings. After reducing cooling/heating loads through passive design strategies, enhancing the efficiency of HVAC systems should be the top priority for any building energy efficiency. Apart from selecting energy efficient equipment, it is important to select the correct system type, size, and design for optimized energy efficiency. The system types are broadly categorized as follows:

- Centralized system: Central chilled water system (Air cooled and water cooled)
- Distributed system (DX system): VRF, Duct able system, split air conditioners, unitary systems

Energy saving potential in HVAC System Design is shown in Table 8.2.

**Table 8.2: Energy Saving Potential in HVAC System Design**

Component	Cooling Load (kW/ton)		Improvement Potential
	Conventional Design	Optimized Design	
Chiller	0.75	0.50	33%
Air Distribution System	0.60	0.06	90%
Water Pump	0.30	0.04	87%
Cooling Tower	0.10	0.02	80%
<b>Total</b>	<b>1.75</b>	<b>0.62</b>	<b>65%</b>

#### High efficiency chillers

Chiller is the highest energy consumer in the HVAC system. Chiller efficiency is rated in kW/ton or coefficient of performance (COP). The efficiency is considered either in full peak load or part load (IPLV). ECBC states the minimum requirement of COP for each chiller type and size. Today, water-cooled chillers are available in the efficiency (COP) range of 6.3 to 6.7. Air-cooled system is designed to achieve COP in the bandwidth of 3 to 3.3.

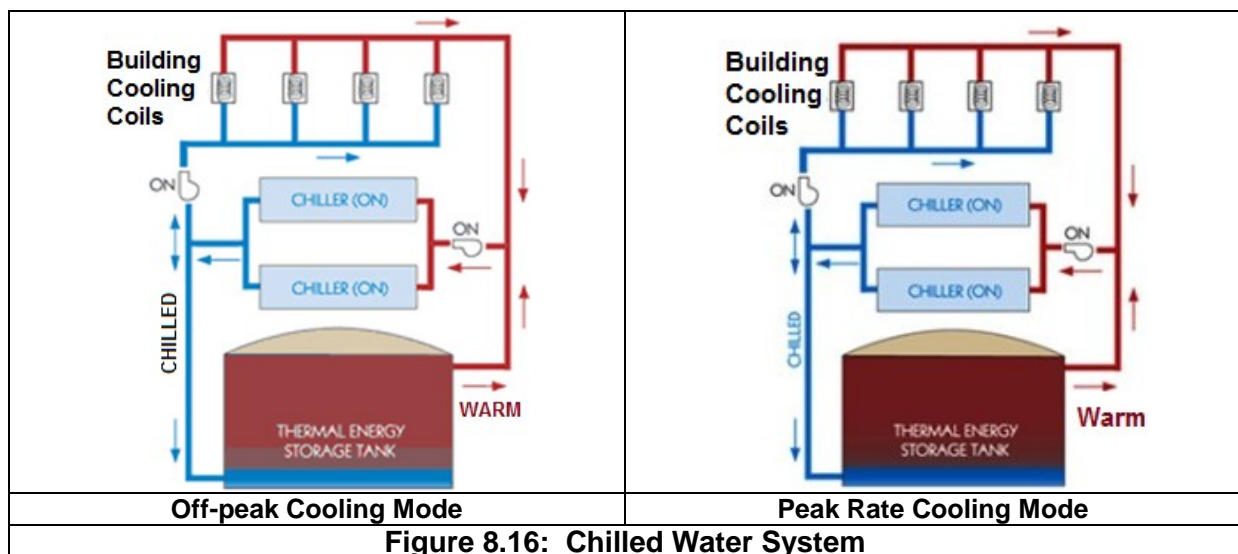
### Water-cooled chillers

Water-cooled chillers reject heat to a condenser water system, in contrast to air-cooled chillers which reject heat directly to the atmosphere. Condenser water systems connected to cooling towers or 'hybrid wet-dry coolers' result in chillers running more efficiently in the majority of weather conditions. Where there is a substantial alternative water source (for example storm water harvesting) this can be utilised.

### Chilled water storage

Chilled water storage allows chillers to operate at times of day that differ from when air conditioning is needed. Chilled water system is illustrated in Figure 8.16. Chilled water is typically created overnight (when chillers operate more efficiently due to cooler ambient temperature), stored in very large well-insulated tanks (designed to allow the coldest water to sink and warmer water to rise), and drawn upon as needed. In locations with a strong 'diurnal swing' in temperature, the additional energy for pumping is more than offset by the lower chiller energy. The system provides following benefits:

- Encourages consumers to operate the chillers during off-peak period when unit charges for electricity are lower thereby lowering the cost of electricity for cooling.
- By shifting the operation of chiller compressor to evening and night hours when ambient air temperature is cooler enables chiller to operate more efficiently and consume less power for cooling.
- Potential for negotiating for lower contract demand and thereby lower demand cost.



### Ice Bank

This system is similar to chilled water system. Blocks of ice are created at night during off-peak periods, typically night time. Chiller cools an ethylene glycol solution to below 0°C and the solution is circulated through tubes in a tank freezing the water held in the tank (Figure 8.17). During the

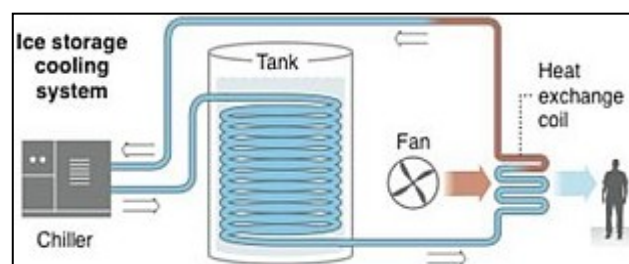


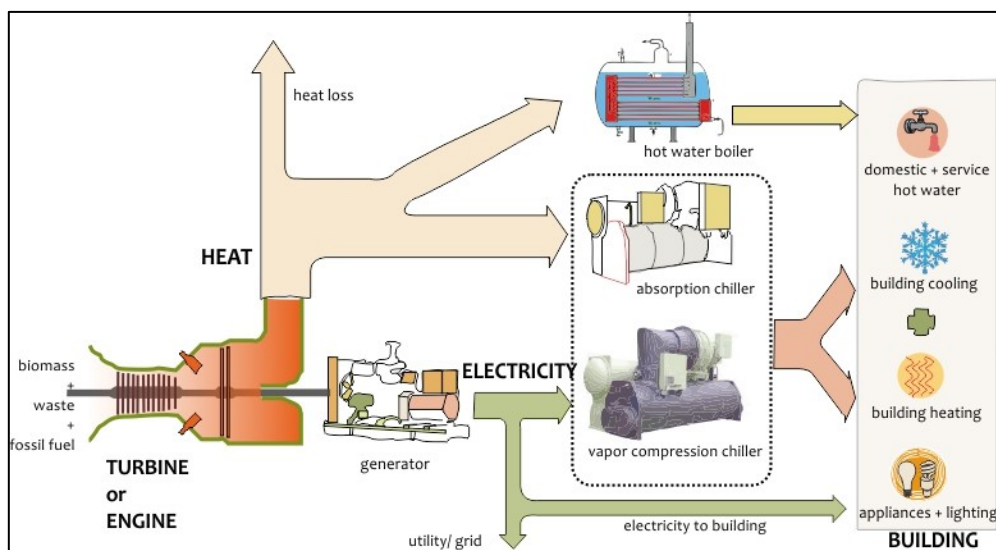
Figure 8.17: Ice-Bank System

day, the ice melts cooling the solution in the tubes. The chilled solution is moved through a heat exchange coils where it cools the air.

### Trigeneration System

Trigeneration systems produce heat and electricity which in turn can be used for heating, cooling and hot water heating systems in a building. Electricity produced can also be supplied to the grid if not needed in the site. It is also known as Combined Cooling, Heating, and Power (CCHP).

Tri-generation technology (Figure 8.18) comprises of a gas engine or a power system operated by burning waste, bio fuel, or fossil fuel to produce electricity. The connected heat recovery system is used as a heat exchanger to recover exhaust heat from the engine. The recovered heat can be used for heating applications like hot water, or in absorption chillers for producing chilled water for cooling. The electricity produced within the tri-generation process could be used to meet the building loads or power chillers during peak load period. The thermal energy could be diverted to boilers to heat the water used in hospitals, hotels, and industries for numerous purposes and/ or to absorption chiller to heat the absorbent and refrigerant mixture and regenerate the absorbent. Larger buildings with a constant high demand for hot water are ideal candidates for its application. Trigeneration systems are more commonly used in buildings with readily available waste heat and intense 24 hours operations.



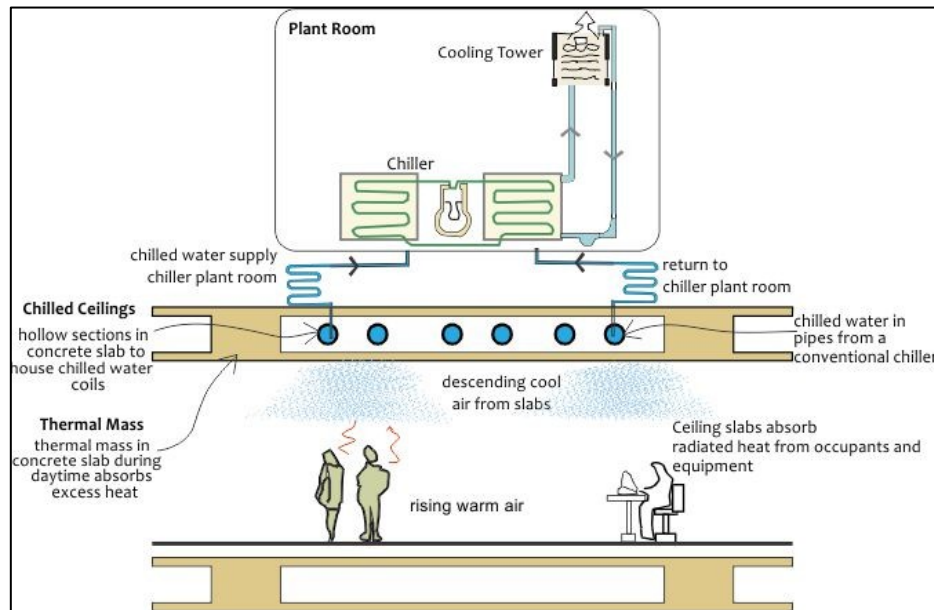
**Figure: 8.18: Schematic diagram of a Trigeneration system**

### Radiant cooling system

Buildings designed with radiant cooling system offers energy savings, exceeding 30% over an energy efficient building designed with conventional air-conditioning system. This is mainly due to supply of chilled water at higher temperatures such as 14-17°C.

Pipes embedded in the structure cool the thermal mass of the building generally during the hours when it is unoccupied. For cooling, radiant systems use both thermal mass and

nocturnal cooling. Chilled water in the pipes can be supplied through a conventional chiller (Figure 8.19).



**Figure: 8.19: Schematic Diagram of a Radiant Cooling System.**

### **Energy-efficient pumps and fans (HVAC system)**

Pumps and fans which are used in HVAC system are designed to achieve higher efficiency benchmarks with use of IE3 and IE4 (most energy efficient motors).

### **Air tightness**

When the wind (or a ventilation system) causes a pressure difference between inside and outside, air tries to move from one to the other—increasing air conditioning energy. ‘Blower door testing’ is used to measure how air tight a building is, and can be a useful diagnostic tool. Revolving doors perform much better than sliding doors—and where secondary swing doors are required they should be on push-button release to discourage their use.

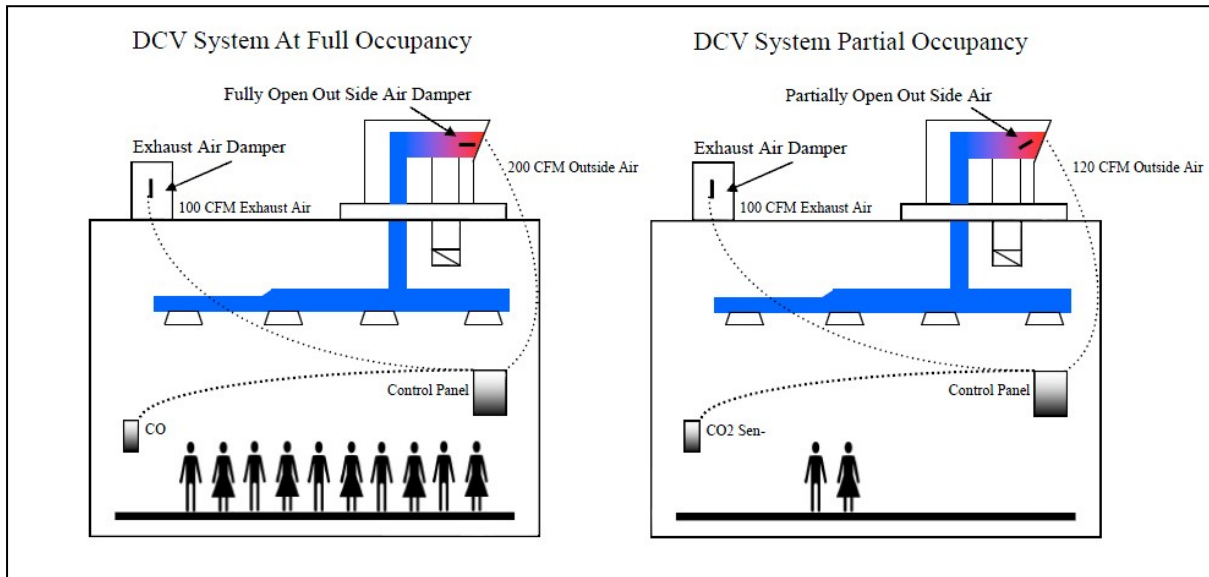
### **Mixed mode ventilation System**

Mixed mode ventilation systems combine mechanical ventilation (which uses fan energy) and natural ventilation. Some buildings have windows that open automatically, others turn-off their mechanical ventilation when someone opens a window. Transient spaces are often ideal candidates for such applications. Buildings designed for natural ventilation can also incorporate a ‘night-purge cycle’ easily, which flushes out hot air from the building overnight.

### **Demand-controlled ventilation (DCV)**

Outside air is pushed into buildings by ventilation systems to dilute the carbon dioxide, odours and other chemicals produced by the people and materials inside. In conventional systems the amount of supply air is constant normally based on maximum occupancy levels or at predetermined ventilation rate, regardless of the occupancy level thus wasting energy

due to fan operation as well as in conditioning and cooling the air—the energy is not only wasted due to the fan operation, but also in conditioning and cooling the air.



**Figure 8.20: Demand Controlled Ventilation**

DCV operation at various modes: full occupancy and partial occupancy is illustrated in Figure 8.20. DCV ensures a building is ventilated, cost effectively, while maximizing indoor air quality. Sensors are used to continuously measure and monitor conditioned space and provide real time feed back to the space controls which adjust dampers or fan speed to modulate the ventilation rate to match with the occupancy of the building. Control technology used is a combination of VFDs, CO<sub>2</sub> or volatile organic carbon (VOC) sensors, and exhaust fan status monitoring. Sensor placement needs to be carefully considered during design – and periodic re-calibration of the sensors is important during operation. Potential energy savings with DCV is 10–40%.

### **Electronically Commutated fans**

Electronically commutated ('EC') fans use brushless motors with permanent magnets and DC voltage controlled by a microprocessor like the fans found in desktop computers. These motors are more energy efficient than conventional AC motors because they do not have the same copper wire windings. The speed of EC fans can be controlled without the need for an external 'variable frequency drives' ('VFD'). This measure is applicable for fans throughout the building (for example in fan coil units).

### **Low-temperature Variable Air Volume**

Low-temperature 'VAV' (Variable Air Volume) air conditioning systems supply colder air (about 11°C as against conventional older (about 14°C), enabled by the development of 'swirl diffusers'. As a result less air needs to be pushed through the system to provide the same amount of cooling, reducing fan energy.

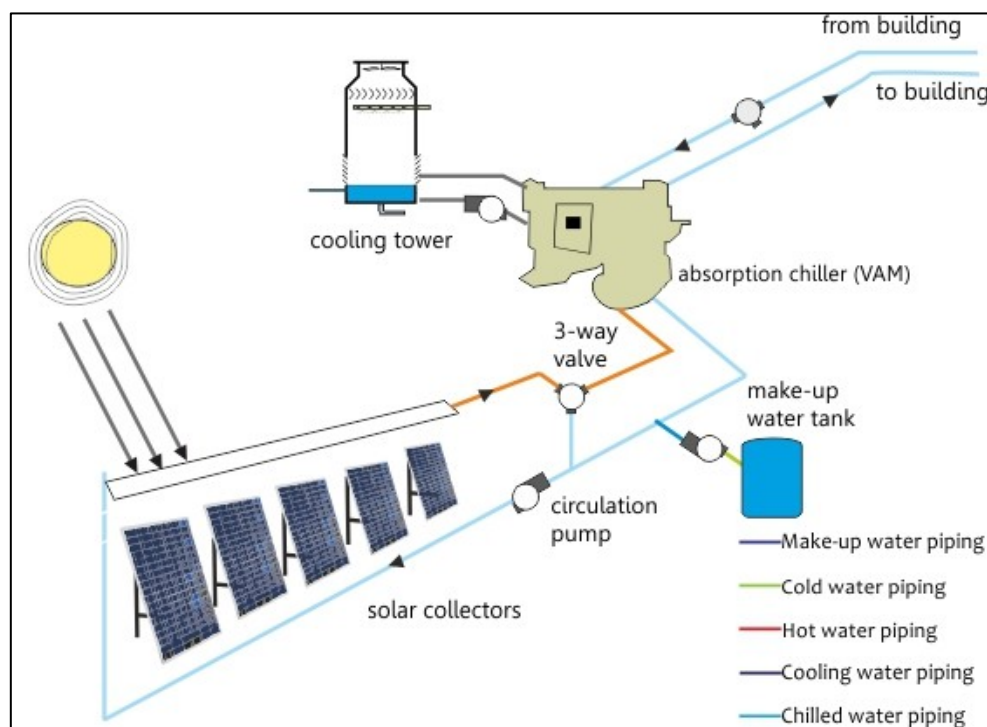
Similarly, 'Low-pressure' ventilation systems are designed for air to be pushed through without applying as much pressure (measured as 'Pa' (Pascals), where lower is better), also saving fan energy. Typical designs target a 'pressure drop' of about 0.8 Pa per metre of duct and aim to minimise the air speed across coils and filters.

### Heat recovery ventilation ('HRV') systems

Heat recovery ventilation ('HRV') systems use the air-conditioned or heated air leaving a building to pre-cool or pre-heat the incoming outside air. 'Run around' pipe heat exchangers (which circulate a liquid between coils in two ducts) and most 'plate' heat exchangers transfer temperature only. 'Enthalpy wheels' and some plate heat exchangers transfer both temperature and humidity. Heat recovery is most beneficial during very hot and very cold weather.

### Solar Cooling

Cooling loads in tropical countries is high during the hot summer season when solar radiation is available in abundance. Thus, application of solar cooling technology uses a renewable source of energy to reduce the cooling loads when air conditioning demand is at its annual high. Solar heat is used to re-generate the refrigerant in an absorption chiller (Figure 8.21).



**Figure: 8.21: Schematic Diagram of a Solar Air Conditioning System**

### Insulated roller doors

Where roller doors are required for access to a cooled space they can be a significant point of heat transfer, resulting in higher energy use. In these applications a product should be chosen that has insulated panels or slats and is well sealed around the edges. Ideally these roller doors should also operate automatically to limit the length of time they remain open. Industrial 'air curtains' (set to only operate in very hot or cold weather) can also be installed to limit air movement into and out of the space while the doors are open.

### 8.5.3 Lighting

International standards have specified lighting efficiency requirement in terms of lighting power density (LPD) to provide flexibility to the designer to meet the design as well as the efficiency requirements. LPD sets the maximum lighting power per unit of area of a building category or space function classification.

ECBC has set the minimum LPD requirement for whole building or for each space function to quantify the maximum allowed lighting power for a respective category to meet the lux level requirement prescribed in the National Building Code (NBC). Use of low Lighting Power Density (LPD) such as 0.45 in green buildings has resulted in significant energy savings in lighting. Such deployment has reduced air-conditioning load as well. In 2005-6, the LPD load which was in the range of 0.9–1.1 W/sq. ft and has come down over the years.

#### LED Lighting

Light Emitting Diode (LED) lighting provides more light for the same amount of electricity when compared to fluorescents, metal halides and halogens. Less heat is generated which also means less cooling energy requirements. LEDs reach full brightness instantly and can be turned off and on again quickly, allowing integration with controls like day lighting and occupancy sensors to further reduce the lighting energy consumption.

In the majority of applications it is important to choose LEDs with a high Colour Rendering Index ('CRI', measured out of 100), which affects how accurately the human eye perceives colour. They also tend to have long life, and less maintenance.

#### Occupancy detection

Occupancy detection uses sensors to identify when people are no longer using a space and switches-off (or turns-down) building systems, saving energy. This application is common for interior lighting, but it is also effective for heating, ventilation, air conditioning and exterior lighting.

There are a variety of different sensor types, suitable for a range of different distances. Some are designed to detect movement; others detect 'presence' (when a person is present but not moving). Systems are even available that have one occupancy sensor per light, providing a high level of responsiveness and energy efficiency. ECBC specifies occupancy sensors to all office areas such as meeting and conference rooms, school classrooms, and storage spaces.

#### Daylight dimming

Daylight dimming (sometimes called 'daylight harvesting') uses sensors to identify when there is a good amount of natural daylight available and turns down lighting, saving energy. The sensors used are called 'PE cells' (photoelectric cells) - for external lighting it is normally just called 'PE cell control'. A sensor can either be built into every light or shared between groups of lights – but it is important to keep groups of lights small (because, for example,

blinds might be adjusted). Internally, it provides the most benefit near facades, skylights and atria.

### **Flexible Lighting Control**

Using only the lights when and where needed results in less energy use. Flexible lighting control systems provide the ability to link any individual light to any particular switch or sensor, without altering any physical connections. This allows the grouping of lights to be easily reconfigured – for example when desks are rearranged in an office. It also enables separate lighting ‘scenes’ to be setup where a space is used for a number of different purposes. Some control systems allow people to change the brightness of an individual light using their smartphone.

## **8.5.4 Renewable Energy**

### **BIPV**

Building integrated photovoltaic (‘BIPV’) materials generate electricity from sunlight and also replace the function of a conventional building material—for example glass or roof tiles. BIPV can use higher efficiency ‘crystalline’ silicon technology, but often uses ‘amorphous thin-film’ technology, which is better suited to dim and diffuse light and can be applied on curved surfaces. There are coloured options, opaque options, and options with different transparencies. BIPV is particularly attractive for high-rise buildings where the roof space is relatively small.

### **Solar hot water systems**

Solar hot water systems collect heat from direct sun, usually for domestic hot water purposes – reducing the requirement for gas or electricity. In ‘flat plate’ systems, water flows through a dark-coloured panel. In ‘evacuated tube’ systems, a liquid flows through dark-coloured double-walled glass cylinders, then transfers the heat to water in a storage tank. Evacuated tube type systems are more thermally efficient, particularly in cold weather. Usually solar hot water systems are fitted with a gas or electric heating element to ‘boost’ the hot water temperature when the solar contribution alone is not sufficient.

## **8.5.5 Other areas**

### **Power factor correction**

Large buildings are often charged not just for how much electricity (kWh) they use, but also for their ‘peak demand’ (the peak power drawn from the grid at any time). In many locations this is based on ‘apparent power’ (measured as ‘kVA’, where lower is better). For buildings that have a poor ‘power factor’ during peak periods, ‘power factor correction’ equipment can be installed which reduces the apparent power drawn from the grid, thereby saving cost. The main causes of poor power factor are generally ‘AC’ motors (including pumps, fans and appliances) and some ‘switched-mode’ power supplies for computer equipment. All 3 phase shall maintain their power factor at the point of connection in the range 0.97–0.99.



### **Sub-metering systems**

Sub-metering systems use a number of carefully placed energy meters 'downstream' of the main utility meter to pinpoint how different parts of the building are using energy. This allows energy loss to be identified, and helps in managing improvement. Connecting sub-meters to a Building Management System ('BMS') will automatically record all the data in one place, with software that can shape it into useful graphs, and provide alerts when any unusual consumption is detected. It can also be linked to display screens inside the building to show live energy use information to occupants.

### **Energy Efficient Appliances**

Unitary air conditioners (if used in the building) should be minimum 3 star rating or above or air conditioner with a COP equivalent to 3.1 (EER of 10.58) or above.

Pumps and fans used in HVAC system are designed to achieve higher efficiency benchmarks with use of IE3 and IE4 (most energy efficient motors) or BEE 3 star rating or more.

### **Electrical Energy Storage**

Energy storage which can make best use of non-dispatchable onsite and offsite solar and other renewable energy options is another area becoming important. Storage of electricity does not reduce overall energy consumption, but it can provide other benefits. Some systems store and re-use excess electricity instead of feeding it to the grid - offering some cost benefit, as well as improving Energy Rating of the building. Other systems store off-peak grid electricity for re-use in the peak-period, to reduce the maximum demand on the grid. Lithium ion batteries are the smallest and lightest option, but are expensive. Flow batteries (zinc bromide for example) can be completely drained without impacting performance, but are larger and heavier.

### **Building Energy Management System ('BEMS')**

A Building Energy Management System ('BEMS') is a dedicated computer and network that controls and monitor all the equipment (such as pumps, fans, 'dampers', chillers, lighting, renewable energy system, elevators, etc.) that are part of the building HVAC system. They can provide very sophisticated control, but their influence on energy efficiency depends on how they are designed. BMS control based on energy efficiency rather than temperature control can realize substantial energy savings. As sensor prices have come down, installing more sensors enables more sophisticated approaches to monitor and control the system more effectively.

### **Crystalline Water proofing**

Newly constructed buildings are expected to last at least for 50 years. Concrete is one of the most commonly used building and construction materials. However, due to its porosity (*micro porous* structure) and *permeability*, it is often susceptible to damage and deterioration from water and chemical penetration.

These properties result in pathways to form that allow the ingress and movement of water into, and through, along with the cracking that occurs due to shrinkage. Thus, these voids,

pores and capillaries become the major sources for water leakages from the concrete structures. As a result, structure of buildings is damaged and expected life of the building is drastically reduced.

One type of waterproofing has proven particularly suitable for *green building*—crystalline waterproofing technology. Crystalline waterproofing system transforms the porous concrete into a water-resistant impermeable barrier which provides a powerful protection against water damage such as cracking and corrosion of reinforcing steel. The other benefits include preventing air entry into or out of a building, which can reduce the cooling/heating requirements.

The crystalline waterproofing chemistry can be introduced into new concrete as an admixture, a dry-shake product, or a surface-applied coating. It becomes an integral part of the concrete matrix when applied to existing concrete or added to the mix at time of batching. For older (i.e., cured) concrete, surface-applied coatings are used.

### **8.5.6 Emerging Trends**

#### **BM Analytics**

Building Management (BM) analytics complements BEMS and is based on statistical analysis, performance trending and automated diagnostics. BM works with BMS to analyse all the data that it collects and generates. The software can search for patterns that indicate equipment is operating efficiently or not, and generate a list of actions for predictive maintenance. Their effectiveness depends on the information available to the BMs and how proactively the actions are implemented.

For new buildings, BM analytics should be embedded in the purchased BEMS. For existing older buildings BM analytics can be incorporated in BEMS with potential payback period of around 5 years.

#### **Self-Learning Buildings**

The application of analytics in Building Energy Management also leads to development of *Self-Learning* buildings. Self-learning buildings use wireless sensor technology and data mining methods to increase their energy efficiency over time by anticipating and meeting their occupants' needs. Data such as temperature, humidity, luminance, and occupancy are collected and transmitted using wireless sensors. The software then learns to optimize heating and ventilation so that energy consumption is minimized without affecting the user comfort.

#### **Use of simulation for energy efficiency in building**

##### **New Building**

Energy simulation has been used in new and existing buildings. Some of the key benefits of building simulation in new buildings are as follows:

- Optimize energy performance. Building simulation establishes the impact of key simulation inputs such as Lighting Power Density (LPD), set point, window-to-wall ratio (WWR), orientation and fresh air intake on energy consumption.

- Support project team in early decision making, such as capacity of electrical/ HVAC equipment ,
- Determine several alternatives for better benefits during operation and maintenance (O&M)
- Evaluate/check code compliance and Green Building Certification programmes and determine enhanced energy performance.

### **Existing Buildings**

- a. Revalidate building performance after one or two years of building operation. Also, compare the building performance after occupancy, as per M&V protocol.
- b. Support decision making with calibrated simulation during retro-commissioning/re-commissioning of equipment– electrical and HVAC.
- c. Predict energy savings with cost savings/payback with proposed implementation of energy efficiency measures in existing buildings.

### **Green Leasing**

Green leasing is a new and emerging concept within the green building world. Green leases (also known as energy efficient leases, or high performance leases) align the financial and energy incentives of building owners and tenants so they can work together to save energy, conserve resources, and ensure efficient operation of buildings.

If a tenant in large commercial building makes efficiency upgrades, but if the building is not sub-metered, there is no means for the tenant to quantify the savings and receive recognition for the achievements. The tenant would have spent money for an energy efficiency upgrade, but may not be sufficiently benefitted from the energy savings created by that upgrade. Similarly a landlord would have invested in energy efficient upgrade and would not being sufficiently compensated for the efforts as the entire benefits in terms of lower utility bills would pass to tenant.

Green lease concept provides means to acknowledge such sustainable practices. By including a few new or modified clauses in a traditional commercial lease, both owners and tenants can better realize the benefits of investing in energy efficiency measures.

The benefits other than energy efficiency that a landlord can benefit from green lease include increased property value, higher occupancy for green buildings, increased ability to recruit and retain employees, higher employee morale, fewer sick day days, and increased employee productivity.

## 9. RENEWABLE ENERGY TECHNOLOGIES AND APPLICATIONS

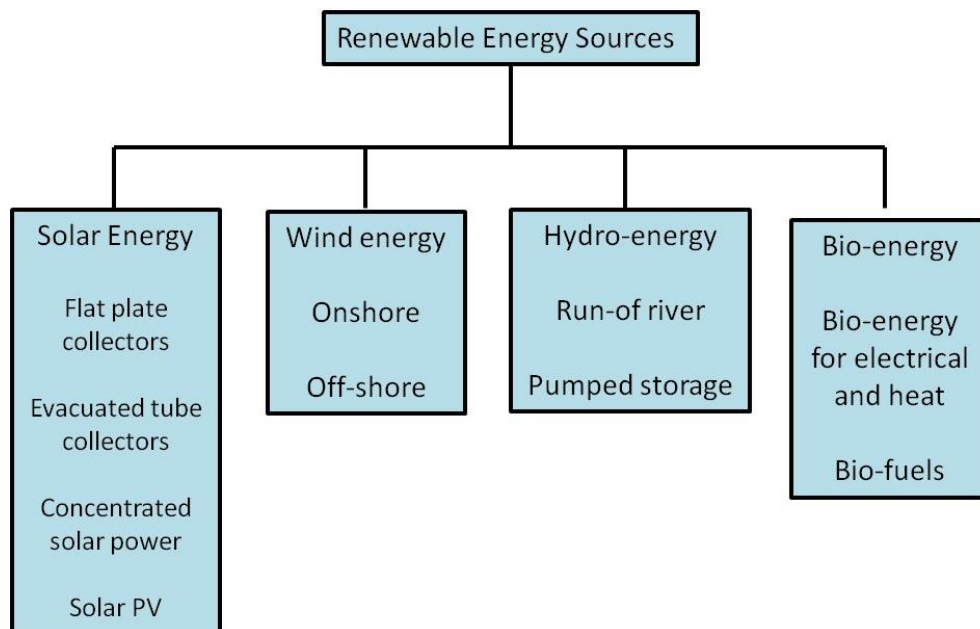
### 9.1 Introduction

The world is currently undergoing irreversible climatic change due to the effects of global warming arising from the massive production and consumption of fossil fuels. To mitigate the impacts, many countries have taken collective decision to reduce the usage of fossil fuels and find alternate energy sources. Among the alternate energy sources, renewable energy sources have huge potential to meet the energy requirements and mitigate the climate change impacts.

The global renewable energy installed capacity was 921 GW (2017), and India's share was around 70 GW. With abundant natural resources such as solar power, wind power, bio-energy and hydro power at its command, the Government of India has set an ambitious target of achieving 175 GW of renewable energy by 2022. This target comprises 100 GW solar power, 60 GW wind power, 10 GW bio-energy, and 5 GW small hydro power. The target is to achieve 21% share of renewable energy in its total electricity consumption by 2022.

### 9.2 Types of Renewable Energy System

Renewable energy system is based on converting the energy found in sunlight, wind, falling-water, sea-waves, geothermal heat, or biomass into a form that can be used such as heat or electricity. The various forms of renewable energy resources are shown in Figure 9.1.



**Figure 9.1: Various Forms of Renewable Energy Resources**

### 9.3 Installable Potential and Installed Capacities

The status of renewable energy in India—potential versus installed capacity—is shown in the Table 9.1.

<b>Table 9.1: Installable Potential and Installed Capacities</b>			
<b>S. No.</b>	<b>Source</b>	<b>Potential</b>	<b>Installed</b>
		302251 MW @100m	
1.	Wind Power	102788 MW @80 m 49130 MW@ 50 m	34193.20 MW
2.	Solar Power - Ground Mounted	50 MW/sq.km	21118.64 MW
3.	Solar Power - Roof Top	-	1210.75 MW
4.	Biomass Power		
5.	Bagasse Cogen	23700 MW	9375.61 MW
6.	Small Hydro (up to 25 MW)	15000 MW	4493.20 MW
7.	Tidal / Wave	Tidal:8000–9000 MW Wave:40000	–
8.	Ocean Thermal Energy Conversion (OTEC)	180000 MW	–
9.	Geothermal	10000 MW	–

### 9.4 Solar Energy

Solar energy—the most abundant natural resource—is easily capable of providing many times the total current energy demand. The average intensity of solar radiation received is 200 MW/km square (megawatt per kilometer square). India is endowed with vast solar energy potential—about 5,000 trillion kWh per year energy incident over land area with most parts of the country receiving 3–5 kWh per sq.m. per day. Based upon the availability of solar radiation and land, the potential of solar power in the country has been assessed to be 750 GWp.

Solar energy can be used in two ways—thermal and electricity. Solar thermal technology uses the solar heat energy to heat water or air or power production. Solar photovoltaic technology on the other hand converts solar energy directly into electricity using photovoltaic (PV) solar cell.

### 9.4.1. Solar Radiation Resource

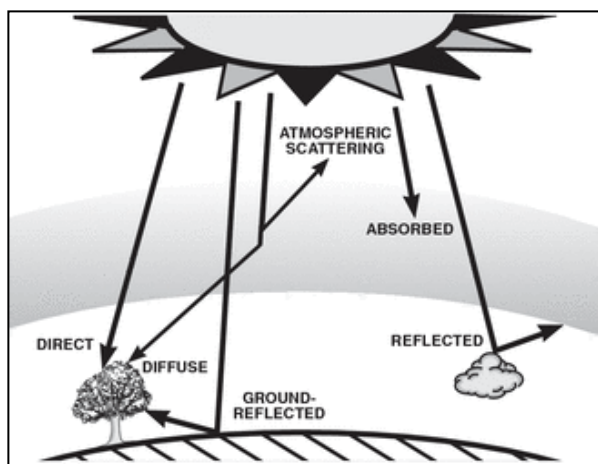
Knowing the quantum of solar radiation is a pre-requisite for site selection and planning for tapping solar energy. Two main sources of solar radiation resource data: satellite-derived data and land-based measurements.

Irradiance is the level of solar radiation on a defined area. Irradiance is therefore an output per area expressed in watts per square metre ( $\text{W}/\text{m}^2$ ). The solar irradiance fluctuate widely—it ranges from  $50 \text{ W}/\text{m}^2$  during severely cloudy conditions to about  $1000 \text{ W}/\text{m}^2$  when the sky is clear.

The solar resource of a location is usually defined by the values of the Global Horizontal Irradiation (GHI), Direct Normal Irradiation (DNI) and Diffuse Horizontal Irradiation (DHI) (Figure: 9.2).

Global Horizontal Irradiation—the total solar energy received on a unit area of horizontal surface—is of most interest to solar PV power developers. As solar resource is intermittent, an understanding of variability is important. Direct Normal Irradiation data is relevant to developers of solar thermal energy particularly based on concentrated solar technologies.

The study of solar radiation map will help to make decision on the location of the solar plant and technology. Maps are available to calculate solar resource of a particular region. The location of a project determines the power production of a solar power plant. However, inconsistency in weather conditions may cause deviations from the initial power projections. Ministry of New and Renewable Energy (MNRE) has prepared Indian Solar Radiation Atlas, with  $3 \text{ km} \times 3 \text{ km}$  spatial resolution, providing details of solar resources (GHI, DHI and DNI) for the benefit of solar developers.



**Figure 9.2: Global Irradiation**

Over the recent years, solar energy has been used in a variety of applications which can be classified into two main categories: solar thermal applications and solar electrical power applications.

## 9.4.2 Solar Thermal Applications

Solar thermal has a broader range of applications than PV does, since the sun's heat can be collected and transferred in a medium, and the stored energy can be used for heating and cooling a home, heating water, cooking food, or producing electricity.

Solar thermal energy is used in three ranges of temperatures: low-temperature, which is used for heating, cooling, and ventilation; mid-temperature, which is used for cooking, water heating; and high-temperature, which includes generating electricity.

### 9.4.3 Flat Plate Collectors (FPC) based Solar Water Heaters

Flat Plate Collectors consist of an insulated outer metallic box covered on the top with glass sheet. Inside the box, selectively coated black absorber sheets with in-built channels or riser tubes absorb the solar radiation and transfers the heat to the flowing water (Figure 9.3).

It has three main components, namely,

- a) Solar collector
- b) Cold water tank
- c) Insulated hot water storage tank with required insulated hot water pipes and accessories.

In the case of smaller systems (100–2000 litres per day), the hot water reaches the user end, by natural circulation (thermo-syphon) for which the storage tank is located above the collectors. In higher capacity systems, a pump is used for forced circulation of water.

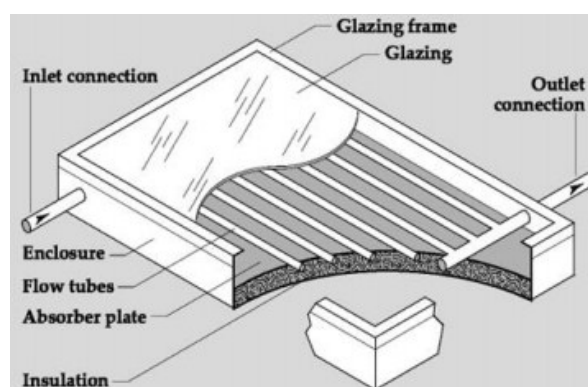


Figure 9.3: Flat Plate Collector

A typical 100 litres insulated tank with a 2 m<sup>2</sup> collector area, can supply water at a temperature of 60–80°C. A bank of collectors can be arranged in a series-parallel combination to get higher quantity of hot water. This system is mainly for domestic hot water applications such as bathing, utensil cleaning etc. For a house with one bathroom and 3 to 4 members, 100 liter per day capacity system should be sufficient.

Capacity (in LPD) for 60°C SHWS	Recommended Collector Area (in Sq. m)
100	2
200	4
300	6
500	8
1000	16

#### 9.4.4 Evacuated Tube Collectors (ETC) based Solar Water Heaters

Evacuated tube collector consists of parallel rows of tubes connected to a header pipe (Figure 9.4). The tubes are made of double layer borosilicate glass tubes evacuated for reducing heat losses. The outer wall of the inner tube is coated with selective absorbing material. This helps absorption of solar radiation and transfers the heat to the water which flows through the inner tube. Compared with FPC, ETC has following benefits:



**Figure 9.4: Evacuated Tube Collector**

- Evacuated tube collector produce higher temperature (up to 177°C) than flat-plate collector.
- ETC exhibits higher efficiency at higher temperatures unlike FPC whose efficiency falls with rise in ambient temperature,

The collector area required for system is 1.3 sq.m./100 LPD (for above 500 LPD capacity). Industrial applications include pre-heating of boiler feed water, cooking/dishwashing in industrial canteens, washing of milk cans in dairies, sterilization of surgical instruments etc.

#### 9.4.5 Concentrated Solar Power (CSP)

This solar thermal generation technology creates the effect of multiplying effects of the sun to produce electricity or direct heating. The most common classification of CSP modules is by the degree of concentration (or concentration ratio), which is expressed in terms of number of "suns". For example, "80x" means that the intensity of the light that hits the photovoltaic material is 80 times than it would be without concentration. Concentrating solar also means direct sunlight rather than diffuse light, limiting this technology to clear, sunny locations. It also means that, in most cases, tracking is required. One of the key benefits of CSP over PV is that the heated fluids can be used to store energy from the sun for later use.

Solar concentrators include parabolic dish collectors, linear parabolic trough collectors and linear Fresnel collectors. Parabolic dish collector—which is the predominant technology in India—can generate temperatures of up to 400°C.



### 9.4.6 Parabolic Solar Dish Collector

Solar dish collector consists of a parabolic reflector dish focusing sunlight onto the focal point in front of the dish collector where heat absorber is located (Figure 9.5). The solar dish collectors can consist of flat mirrors attached to steel or aluminium frames. Some dishes are static and need to be manually adjusted (2–3 times a day) to follow the sun, while others track the sun automatically



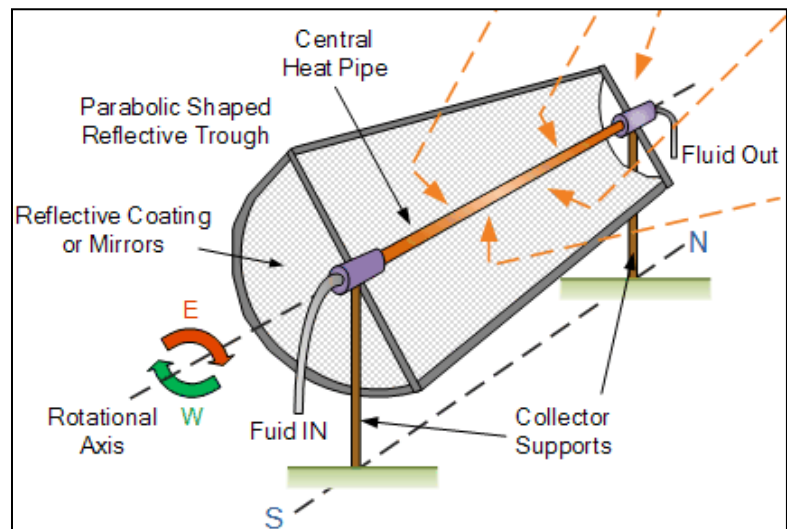
**Figure 9.5 Solar Dish Collector**

The focused beam of intense solar energy generates heat. Due to the very high temperatures at the focal point, a thermal oil type fluid is generally used instead of water inside the absorber. The heat absorber can be as simple as a small evacuated tube or a more complex solar heat engine, such as a Sterling Engine to produce power. As well as generating electricity, the concentrating type parabolic solar dish can also be used for cooking applications.

Designs popularized in India include Scheffler dish and ARUN-160 dish—a two-way tracking parabolic dish with an aperture area of 160 m<sup>2</sup>, weighing around 20 tonnes and generating 100-120 kg of steam per hour (between 80-100 kW of thermal output).

### 9.4.7 Parabolic Trough Collectors (PTC)

PTC is the most mature among the CSP technologies. The direct radiation falling perpendicular to the parabolically curved, trough shaped mirrors is reflected and concentrated on an absorber pipe located in the length of the focal line (Figure 9.6). Heat from the absorber pipe is removed by circulating heat transfer fluid through the pipe and is utilized to produce electricity or process heat. PTC is normally tracked in single axis and oriented in north-south direction for good energy yield.

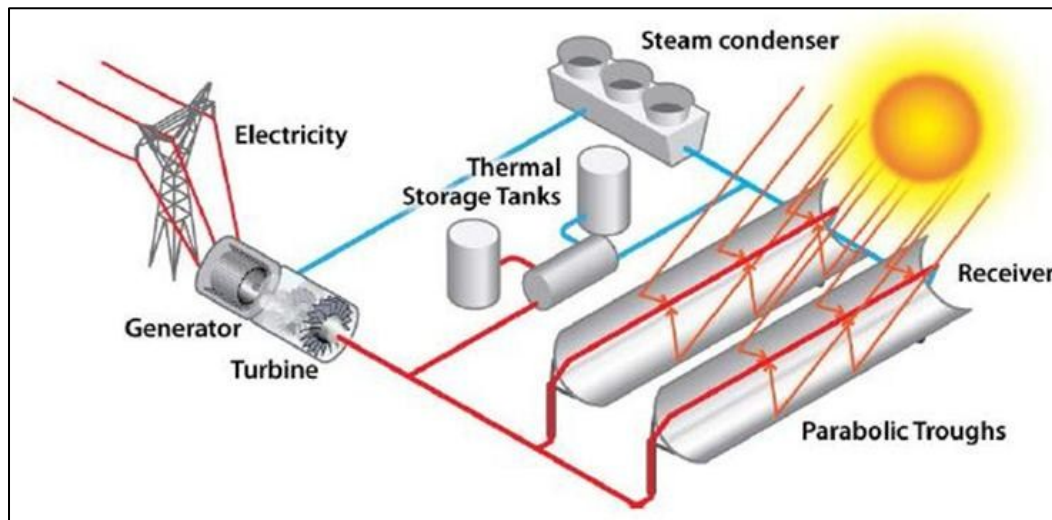


**Figure 9.6: Parabolic Trough Collector**

Concentration ratios up to 80 and heat transfer fluid temperatures up to 550°C have been practically achieved. The applications include industrial and commercial scale power generation

or cogeneration, solar cooling, milk pasteurization, boiler feed water pre-heating and process hot water/steam supply.

Parabolic Trough Power Plant (PTPP) is thus far the most developed CSP thermal plants that are operating commercially. The sun's energy heats up the heat-absorbent medium (mineral oil, synthetic oil, molten salt etc.), which carries the energy to the water in a boiler heat exchanger, reaching a temperature of about 400°C. The heat is transferred into the water, producing steam to drive turbine (Figure 9.7).



**Figure 9.7: Schematic of a PTPP with a Thermal Storage System**

#### 9.4.8 Linear Fresnel Collectors

Linear Fresnel collectors are similar to parabolic trough collectors, except it substitutes large parabolic curved mirrors with an array of smaller linear or slightly curved mirror strips which reflect the solar radiation onto a receiver line mounted above them. These high-concentration collectors produce temperatures up to 400°C and are extremely suitable for potential industrial process heat applications.

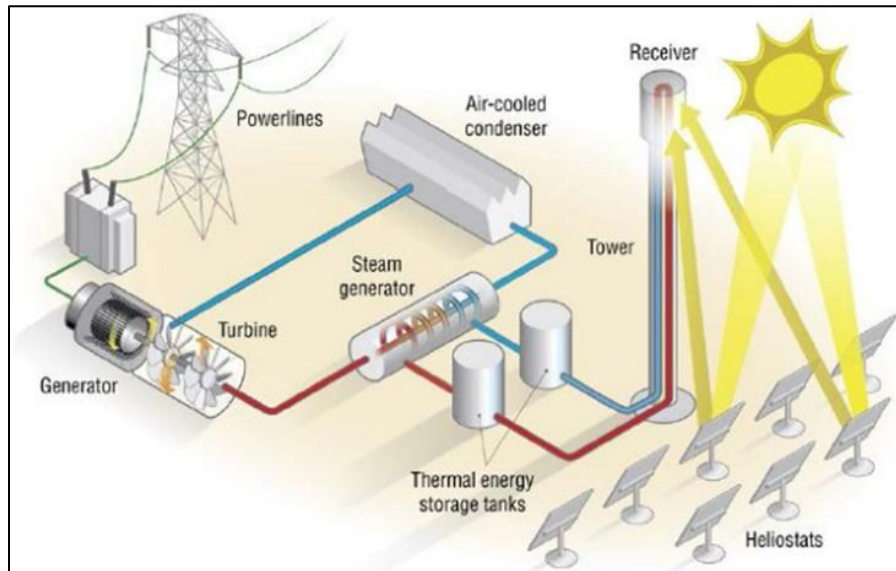
The above systems can be direct systems (open loop systems) that can use water or air as the heat transfer fluid, or indirect systems (closed loop systems) that can use other fluids such as molten salts or synthetic oil.

#### 9.4.9 Power Towers

This configuration uses hundreds or thousands of flat mirrors called heliostats to focus and concentrate the sunlight on a central fixed receiver (Figure 9.8). The heliostats are arranged in a circular pattern and each heliostat tracks the sun and reflects sunlight onto the central receiver mounted on the top of a tower located at the centre of the heliostat field. Due to the use of large

numbers of reflectors and the high levels of concentration, very high temperature—about 550°C is achieved.

The working fluid that receives all this heat can be water, high specific heat capacity oil or molten salts. A high specific heat ensures large storage of thermal energy in molten oil or salt. The working fluid is moved from the tanks to a heat exchanger where water is heated to produce superheated steam to drive turbine and generate electricity. The efficiency level is similar to that achieved with thermal-fired electricity generators.



**Figure 9.8: Power Tower**

This technology is more flexible than solar PV plants because of energy storage and ability to produce power based on the grid demand. Currently, concentrated solar thermal can store enough heat to produce between 3 and 17 hours of electricity, which makes generation almost continuous and reliable. The capacity factor of a concentrated solar thermal plant can reach up to 60% with energy storage, which is much more than the capacity factor of a solar PV plant.

#### **9.4.10 Industrial Applications of Solar Thermal Energy**

##### ***Solar cooling***

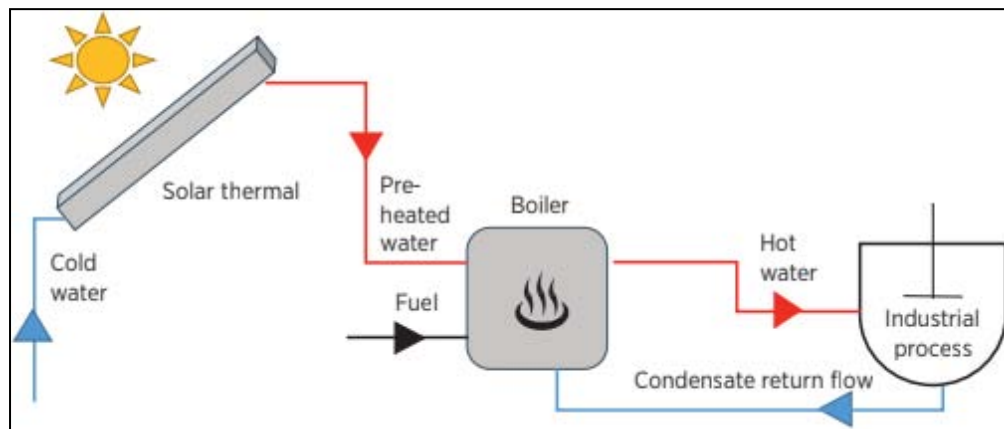
Solar thermal cooling systems based on absorption chillers can be used to replace electricity-driven, vapour-compression air conditioning systems.

In absorption chillers (the most common system), solar energy is used to regenerate the absorber fluid containing the refrigerant. Two common absorption chiller systems are ammonia-water ( $\text{NH}_3/\text{H}_2\text{O}$ ) or water-lithium-bromide ( $\text{H}_2\text{O}/\text{LiBr}$ ), as refrigerant/absorber fluids.

Single effect chillers require lower temperatures (70–100°C) to operate and can be driven by conventional solar thermal collectors such as FPC and ETC. Large cooling capacities (>100 kW) and high temperatures for double-effect chillers (150–180°C) and triple-effect absorption chillers (200–250°C) cannot be met by conventional solar thermal collectors and require solar concentrators (parabolic trough collector).

### ***Integration of solar heat into industrial processes***

Most industrial processes require heating of a fluid stream (e.g. hot air streams, hot water, liquid baths). Existing heating systems for industrial process are based on steam or hot water from a boiler, which mainly uses fossil fuels like oil, gas and coal or electricity generated by different sources. An example of integration of solar heat by direct pre-heating of feed water supply to boiler is shown in Figure 9.9.



**Figure 9.9: Solar Thermal Heat for Pre-heating of Feed to Steam Boiler**

#### **9.4.11 Solar PV Technology**

Solar PV is a semiconductor device which converts sunlight directly into electricity. A solar PV panel, when exposed to sunlight generates voltages and current at its output terminal. The quantum of electricity depends on the intensity of the sunlight.

Photovoltaic system comprises the following components:

- PV Modules
- Inverters & Charge Controllers
- Mounting structure
- Balance of System Components

### ***PV Modules***

The PV modules are devices that actually convert solar energy to electricity (Figure 9.10). They are made from PV cells, which are most commonly manufactured using silicon. The conversion efficiency of silicon-based solar cells varies from 15–20%. These solar cells can be broadly classified into two types: Monocrystalline and Multicrystalline. Monocrystalline silicon has longer life than multicrystalline silicon, but costlier.



**Figure 9.10: PV Modules**

Alternatively, thin film cells are available. The main thin film PV technologies are the CdTe (Cadmium Telluride) PV technology and CIGS (Copper Indium Gallium Selenide) PV technology. Thin film glass modules have efficiencies from 14–18%. Organic solar cells are a relatively new technology. The materials are based on conductive organic polymers or organic molecules based on carbon.

Good quality PV modules are expected to have a useful life of 25 to 30 years.

### ***Inverters***

A solar inverter or PV inverter as shown in Fig 9.11 converts the direct current (DC) output of a photovoltaic (PV) solar panel into a utility frequency alternating current (AC) that can be fed into grid or used on-site.

Inverters are classified based on the mode of operation, size, or implementation topology.

Based on mode of operation, there are (a) inverters for grid-connected system, (b) inverters for stand-alone system, (c) inverters for both grid-connected and standalone types (bimodal inverters).



**Figure 9.11 Inverter**

Inverters are also classified based on capacity, as central inverters (typical > 300 kW) for large scale solar PV plant and string inverter (< 60 kW).

The selection of an inverter for a project depends on a number of factors, including application (with or without battery storage), size, cost, function, usage, etc. Some inverters can also perform energy monitoring functions. Best inverters offer efficiencies in the range of 95%–98%.

Solar inverters incorporate maximum power point tracking or MPPT mechanism to get the maximum possible power from the PV array.

### ***Mounting structure***

The mounting structure is the support structure that holds the PV panels to efficiently capture solar insolation, increase generation, and provide stable structural support. Mounting structures can be either fixed or tracking. Fixed tilt mounting systems are simple, cheap and maintenance-free as against costlier tracking system which continuously orients PV panels with the sun. Due to these reasons, fixed tilt mounting structures are common in India.

Mounting structures for rooftop solar PV installations also require compliance with regulations or guidelines associated with the structural aspects of the roof, such as load-bearing capacity, and wind loading.

### ***Balance of System***

Balance of system (BoS) is comprised of cables, switchboards, junction boxes, and electricity meters.

#### **9.4.12 PV system types**

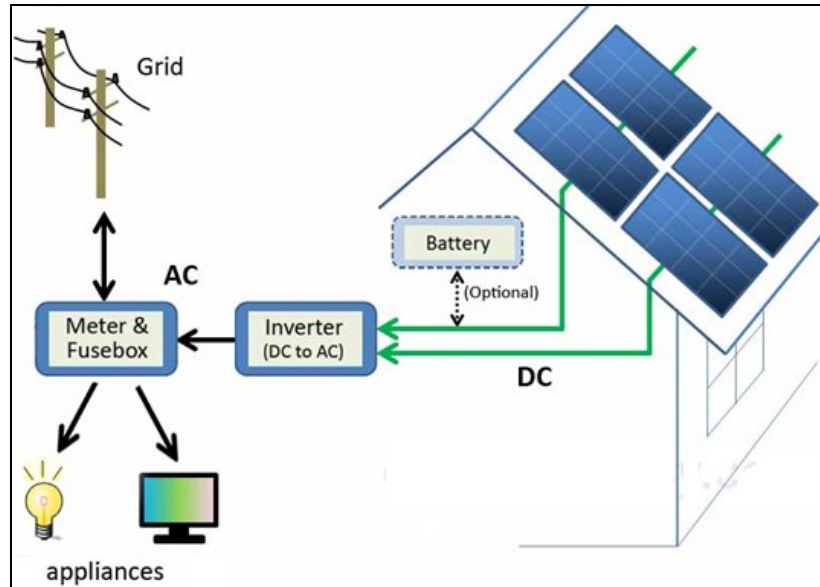
The solar PV power system applications can be categorized broadly as grid-connected (grid-interactive or grid tied) and off-grid PV system.

#### **9.4.13 Grid-connected (Rooftop Solar) PV Plant**

A grid-connected rooftop solar PV plant typically refers to a solar PV system that is located on the roof of a building and is connected to the local distribution grid (Figure 9.12). It is considered as a type of distributed power generation.

The DC power generated from solar PV panel is converted to AC power using inverter/power conditioner and fed to the grid. Power generated during the day time is utilized fully by captive loads and excess power if any is fed to the grid. In case, when solar power is not sufficient due to cloud cover etc., the captive loads are served by drawing power from the grid.

The grid interactive rooftop system can work on net metering basis wherein the consumer pays to the utility on net meter reading basis only. Alternatively two meters can also be installed to measure the export and import of power separately. Most of the States in India have come out with solar policy supporting grid connected rooftop systems as well as notified regulations on net-metering.



**Figure 9.12: Grid-Connected (Utility-Interactive) PV System**

Grid connected systems normally do not require battery back-up as the grid acts as the back-up for feeding excess solar power. However, to enhance the performance reliability of the overall systems, a minimum battery backup of one hour of load capacity can be adopted.

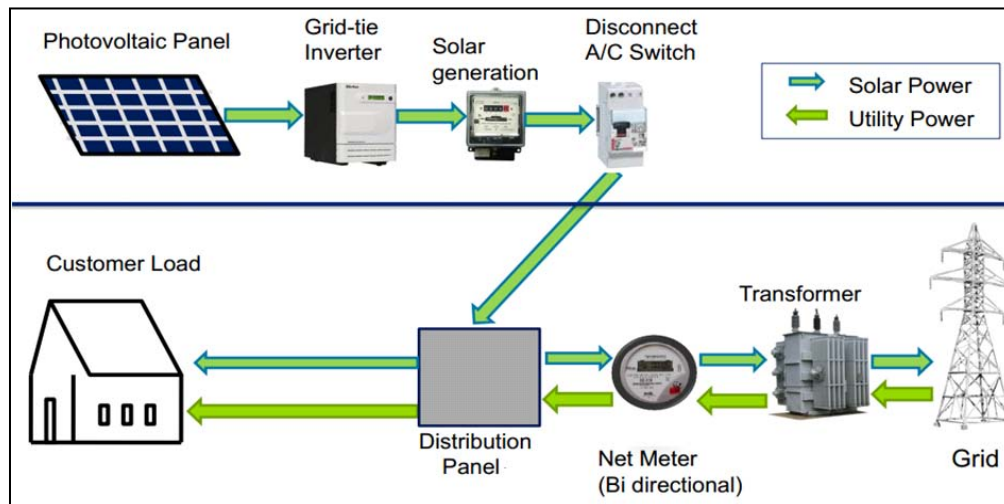
It has to be ensured that in case of grid failure, the solar power is fully utilized or stopped immediately as feeding of power to the grid may cause electrocution to grid person working on maintenance. This feature is called as 'Islanding Protection'.

The grid connected rooftop PV plant generates electricity at the consumer and hence contributes to reducing the network losses of the distribution companies (DISCOMs). The DISCOMs are further benefited as they are able to comply with their solar purchase obligation targets as specified by Electricity Regulatory Commissions.

### **Net-metering**

The energy generated by the solar rooftop plant is first allowed for self-consumption and the excess energy is injected to the grid. Net metering is the concept which records the net energy between export of generated energy and import of utility energy for a billing month. The meter has the feature of recording both the import and export values (Figure 9.13).

Each State has its own rule and method for meters to be used while recording the energy inputs and output. Some States authorize use of single meter which shows net consumption. These types of meters are usually digital meters and run in reverse direction on transferring of power from the solar power system to grid thereby recording net energy between export of generated energy and import of utility energy for a billing month. Some states prefer double meters—one meter to measure energy transferred from the solar power system and the other to record energy consumed from the grid.



**Figure 9.13: Net-metering**

**Benefits of Net Metering:**

- Consumer becomes generator for his own electricity requirements. An average energy consumer becomes *Prosumer*.
- Local utility grid acts as battery—the user need not worry about the shortage or excess power generation.
- Consumer benefits by way of considerable reduction in energy bills.
- Consumer is able to reduce diesel consumption wherever DG backup is provided.

**9.4.14 Approach and Methodology to develop a Rooftop PV Plant**

Before setting up the rooftop PV plant, site survey and analysis has to be carried out and following details have to be collected:

- Available shadow free area (best to have no shade anywhere on array from 9 a.m to 3 p.m).
- Annual electrical consumption
- Minimum shadow free area (12 sq.m. for 1 kWp)
- Sanctioned load
- Load bearing capacity of the roof
- Mounting area

**System Design**

A solar PV system design can be done in following steps:

- Load estimation
- Estimation of number of PV panels
- Estimation of battery bank
- Cost estimation of the system



### *Load estimation*

- It is necessary to know the energy needs from listing all consumer daily loads, such as lights, TV, and other appliances.
- To determine total energy consumption, wattage of the appliance should be multiplied by the number of hours used in a day.
- After adding the energy consumption of each appliance, the power output required from PV system can be determined.

### **Steps to design a Grid-connected rooftop solar PV system**

A sample calculations showing recommended capacity of the solar modules array for a rooftop PV system is shown with following steps.

**Step 1:** Shadow free rooftop area = 60 m<sup>2</sup>

**Step 2:** Maximum system capacity on the basis of the shade-free rooftop area.

Capacity = Shade-free rooftop area (in square meters) divided by 12.

The maximum solar PV capacity that can be installed on this rooftop area

$$= 60/12 = 5 \text{ kWp}$$

**Step 3:** Calculate the system capacity based on annual energy consumption.

Capacity = 90% of annual energy consumption (in kWh) divided by 1,500 hrs.

If annual energy consumption is 15,000 kWh

Solar PV system capacity based on annual energy consumption

$$= (90\% \times 15,000)/1,500 = 9 \text{ kWp}$$

**Step 4:** Recommended Capacity: Take the lower of the above two capacities determined in Step 2 and Step 3.

In this example: 5 kWp

**Step 5:** Solar Grid Inverter Capacity

**Step 6:** Recommended solar grid inverter capacity in kW shall be in a range of 95–110% of the solar PV array capacity.

In the above example, the solar array capacity was calculated to be 5 kW. The solar grid inverter required for this array would be in a range of 4.75 – 5.50 kW used (single phase inverter or three single phase inverter). For systems above 4 kW, three phase solar grid inverters shall be preferred.

The system is expected to last over 20–25 years. Typical payback period is 4–10 years, considering a 15% subsidy on initial investment.

### 9.4.15 Off Grid Solar PV

Stand-alone PV systems are designed to operate independent of the electric utility grid, and are generally designed and sized to supply DC and/or AC electrical loads. Stand-alone PV system requires batteries to store electricity produced by the PV array during the day, and to supply electricity to electrical loads as needed (during night times and periods of cloudy weather).

PV panels are connected together in groups or strings. The DC electricity from the PV arrays flow through charge controller to battery. The controller regulates the DC power to the batteries and protects the battery from overcharge and over discharge. Voltage is generated at 12, 24, or 48 V DC. DC power produced can power small systems such as lights, signs etc. The Inverter converts the DC battery power to AC electricity to meet AC loads (Figure 9.14).

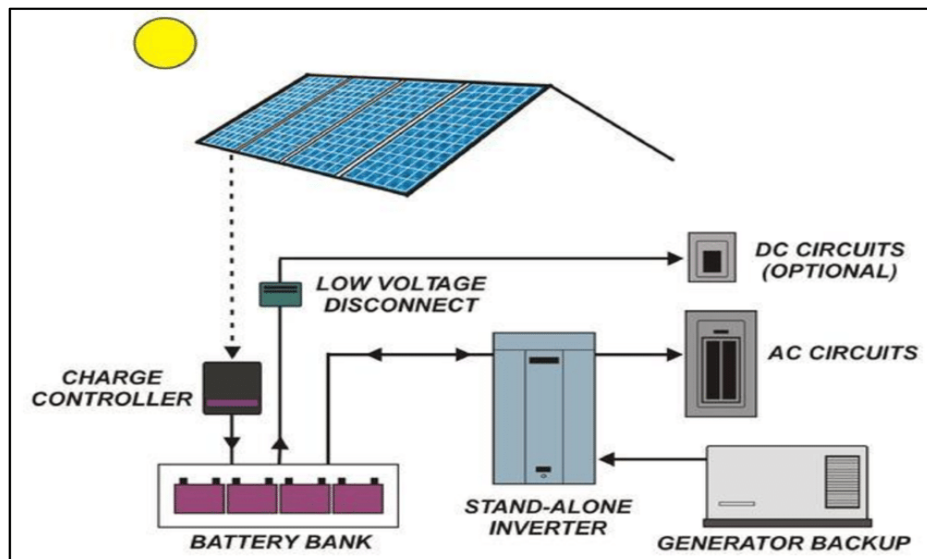


Figure 9.14: Typical Stand-alone PV System Powering DC and AC Loads

Battery charge controller adds significantly to the cost of a PV system. The charging of batteries reduces system efficiency significantly—20% energy losses are typical during battery charging.

The battery capacity for off-grid storage is determined based on the climate (periods of cloudy weather, critical loads etc.). Typically capacity should last for 4–21 days. Battery should not be discharged more than 50–70% to ensure long life.

Typical off-grid solar PV applications are lighting, electricity and water pumping. The users include hospitals, educational institutions, Government offices, commercial buildings, construction companies, telecommunication towers, and petrol bunks. This mode for supply of power needs battery backup.

**Off-grid solar PV system has the following advantages:**

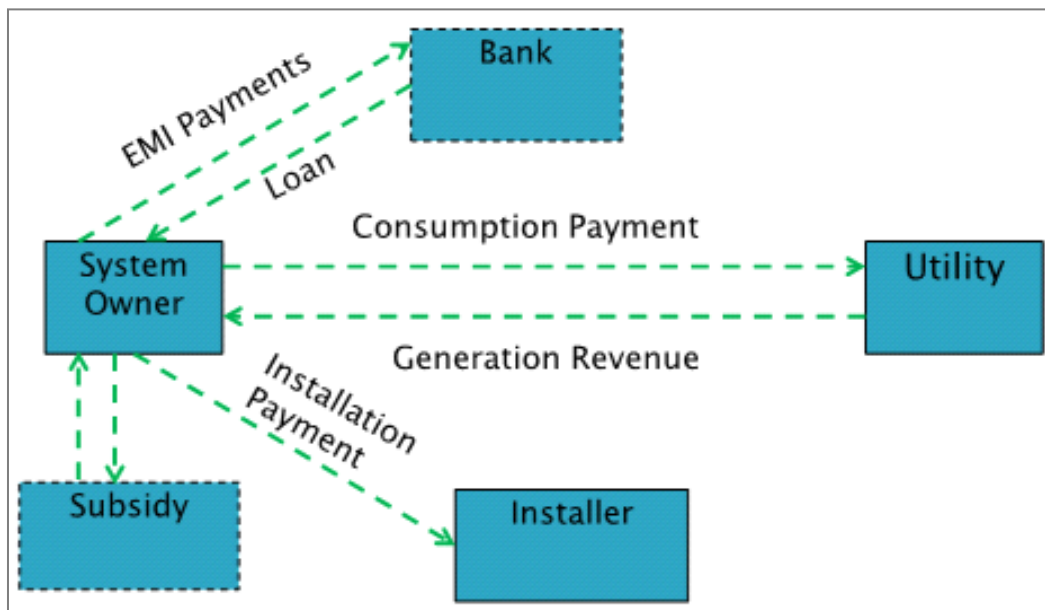
- Continuous access to power
- No scheduled/unscheduled power cuts
- No dependency on diesel
- Power quality better than grid
- Investment against increasing fuel and grid charges.

**9.4.16 Business Models for Installation of Large Capacity Rooftop**

Government has identified rooftop and vacant areas in Government/PSU buildings for installing rooftop solar. Government provides project management consultancy charges (3%) through MNRE. PSUs have carried out site assessment and many have executed the project through RESCO/CAPEX. Model bidding documents were developed for both CAPEX (ownership) and RESCO modes for free downloads and use at MNRE website.

**CAPEX Model**

The borrower sets up rooftop solar project to reduce its own power consumption and feeds residual power to the grid. The execution of the project is executed through Engineering, Procurement and Construction (EPC) contractor. The O&M contract may be given to the same EPC contractor or some other agency. The CAPEX model is illustrated in Figure 9.15.



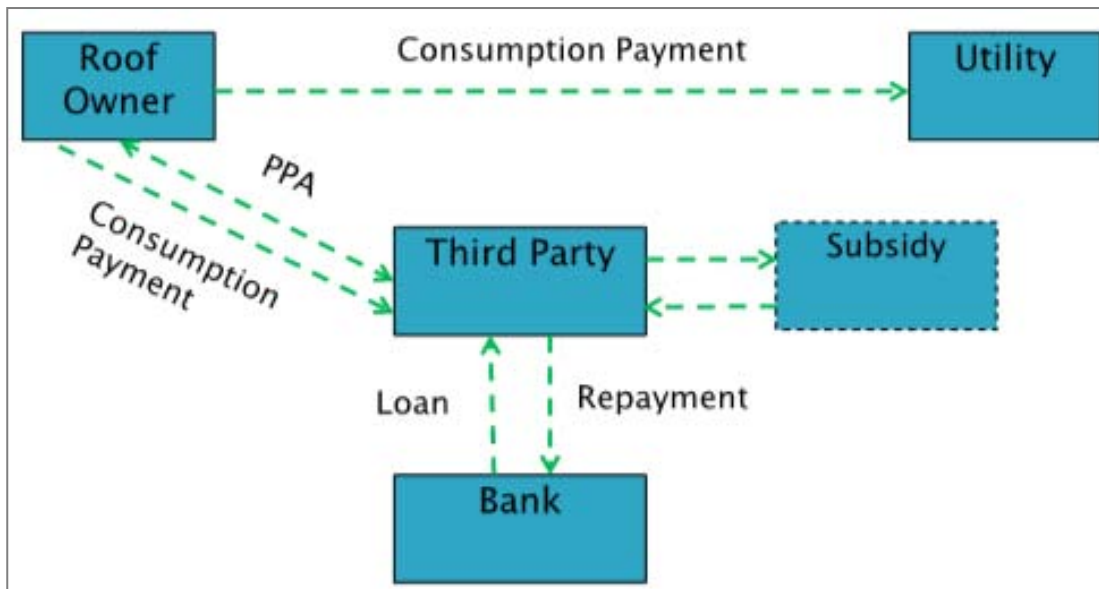
**Figure 9.15: CAPEX Model**

**RESCO Model**

RESCO (Renewable Energy Service Company) develops the rooftop solar project based on agreed terms and conditions. Long-term legally binding lease agreement is executed between

RESCO and the owner of the site on right to use the roof of the owner building on which solar project is being installed (Figure 9.16).

RESCO will also enter into a power purchase agreement (PPA) for the supply of power. The same RESCO may take up multiple projects consecutively and simultaneously across different locations. RESCO would be the borrower in Bank's books and liable for repayment of loan



**Figure 9.16: RESCO Model**

#### 9.4.17 Solar Power Parks

Solar Power Park is a large area of land developed and made available to solar power developers. Such land is free from statutory clearances and provided with common infrastructure facility such as water, transmission lines, roads, drainage, communication network etc. Developers are freed from the burden of seeking number of approvals and focus on executing the project.

MNRE has drawn a scheme to set up number of solar parks with a collective capacity of 20 GW across various states in the country, each with a capacity of minimum 500 MW and smaller parks of 100 MW and above for North Eastern States, HP, Uttarakhand and J&K. Solar Energy Corporation of India (SECI) would be MNRE's Agency for handling this Scheme.

The solar parks are being developed in collaboration with the State Governments and their agencies. For the park, the state will have to provide land to the project developers, which can be either wasteland or non-agricultural land. It would also enable States to bring in significant investment from project developers, meet its Solar Renewable Purchase Obligation (RPO) mandates, and provide employment opportunities to the local population.

The services of Renewable Energy Service Company (RESCO) are being used in developing solar power park. RESCO will design, built, finance and operate the equipment and also bear performance risk. Solar park agency will sign Power Purchase Agreement (PPA) with the RESCO and power supply agreement (PSA) with DISCOM.

**Example:** Charanka Solar Power Project, Gujarat

#### 9.4.18 New Solar Technologies

##### **Solar Skin design**

One major barrier for the solar industry is the fact that most homeowners consider solar panels to be an unsightly home addition. To overcome this issue, Solar Skin design has been created to make it possible for solar panels to match the appearance of a roof without interfering with panel efficiency or production.

##### **Solar cell sandwiches**

Researchers are working on an exciting new material called **perovskite**—a light sensitive crystal which could revolutionise solar power. At present, its power conversion efficiency figure is nearly on a par with traditional silicon at around 22%, but 1,000 times thinner.

This will lead to big drop in price of solar power in future. These third generation solar cells are built-up layer by layer, like a sandwich, with perovskite as the light-harvesting active layer. It is semi-transparent, meaning a building's windows could one day be replaced by coloured plates of perovskite that would also generate electricity. The final layer of the solar cell is gold, which acts as an electrode.

##### **Concentrating Photovoltaics (CPV)**

In Concentrating Photovoltaics (CPV), a large area of sunlight is focused onto the solar cell with the help of an optical device. By concentrating sunlight onto a small area, this technology provides three competitive advantages:

- Requires less photovoltaic material to capture the same amount of sunlight as non-concentrating PV.
- Makes use of high-efficiency multi-junction cells which becomes viable (although costly) due to smaller space requirements
- The optical system is made of standard materials, manufactured in proven processes and thus less expensive than cells.

Concentrating the light also means that direct sunlight rather than diffuse light is required, limiting this technology to clear, sunny locations. It also means that tracking of sun is required.

## 9.5 Wind Energy

Among the non-conventional energy sources, wind energy is proved as the most matured source and popular all over the world for clean and safe production of electricity. Earth's commercially viable wind power potential is estimated to be 72 TW (72000000 MW) which is four times more than the world's present total energy demand. India ranks fourth in the world in terms of cumulative installed capacity (34046 MW as of 2018) after China, USA and Germany.

During sunny hours, air in the atmosphere gets heated up and tends to move towards low pressure regions, creating wind. The kinetic energy of the wind is converted into mechanical energy and then to electrical energy by means of wind energy conversion systems or wind turbines.

Wind turbines convert the energy in the wind to electricity by rotating propeller-like blades around a rotor. The rotor turns the drive shaft, which turns an electric generator. Three key factors affect the amount of energy a turbine can harness from the wind: wind speed, air density, and swept area. Energy in the wind is given by the following relation:

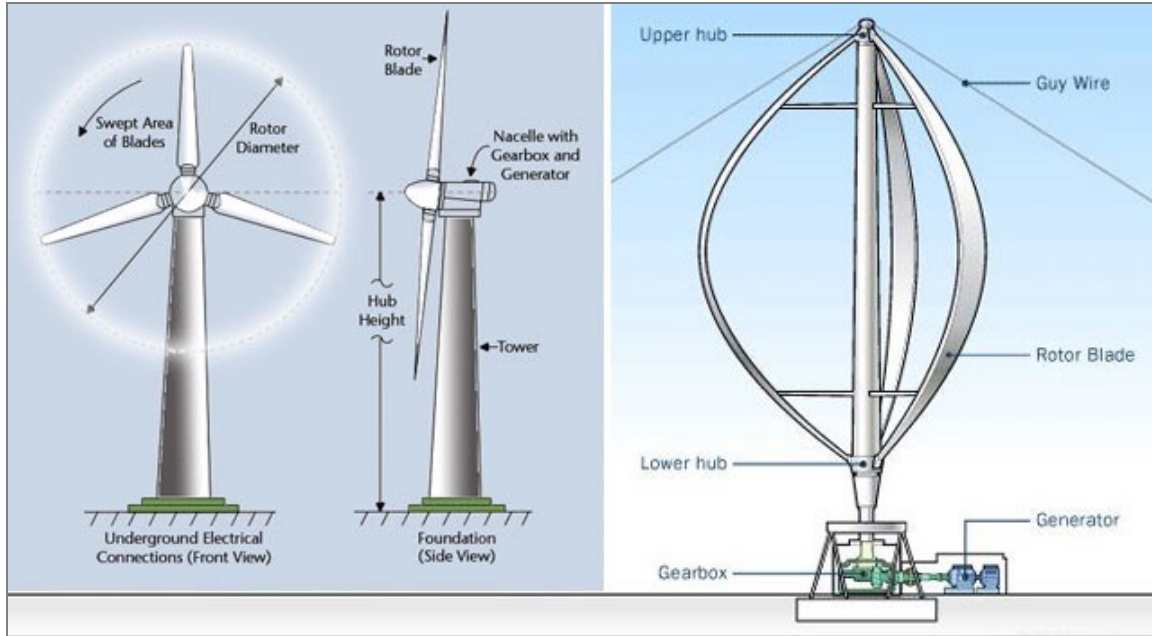
$$\text{Power in the Wind} = \frac{1}{2} \rho A V^3$$

Where,

$\rho$	= Air Density kg/m <sup>3</sup>
Swept Area (A)	= $\pi R^2$ (m <sup>2</sup> ) Area of the circle swept by the rotor
V	= Wind Velocity m/s
Kinetic Energy	= $\frac{1}{2} mV^2$

### 9.5.1 Types of Wind Turbines

Modern wind turbines are categorized into two basic types namely the horizontal-axis and the vertical-axis design (Figure 9.17 and Figure 9.18). Horizontal-axis wind turbines typically have either two or three blades. These three-bladed wind turbines are operated "upwind," with the blades facing into the wind.



**Fig 9.17: Horizontal Axis Wind Turbine**

**Fig 9.18: Vertical Axis Wind Turbine**

Utility-scale turbines range in size from 100 kilowatts to as large as several megawatts. Larger wind turbines are more cost effective and are grouped together into wind farms, which provide bulk power to the electrical grid.

Single small turbines, below 100 kilowatts, are used for homes, telecommunications towers, water pumping etc. Small turbines are sometimes used in combination with diesel generators, batteries, and solar photovoltaic systems. These systems are called hybrid wind systems and are typically used in remote, off-grid locations, where a connection to the utility grid is not available.

### 9.5.2 Development of Wind Project

Once a site is found to be suitable for wind energy development, the availability of that particular land should be explored. The primary objective of a wind project design is to locate the wind turbines in the best wind sites to maximize energy production.

A number of software packages are available to determine the placement of wind turbines at eligible sites (wind turbines are typically arranged in single or multiple rows, depending on the size and contour of the land. A single row is most often used on hilltops where the flat land is very limited. The distance between rows in complex terrain is typically dictated by the terrain characteristics. Multiple rows can be used in a broader and flatter land.

### 9.5.3 Offshore Wind Energy

The advantage of offshore wind power is that the wind is much stronger off the coasts, and unlike wind inland, offshore breezes can be strong in the afternoon, matching the time when demand for electricity is the most. The other benefits of developing offshore wind energy include abundant space, and consistent wind which can increase power output by 40% compared to onshore wind project. India, with long coastline of

over 7500 km, has promising offshore wind potential awaiting exploitation (Figure 9.19).



**Figure 9.19: Offshore Wind Turbine**

### 9.5.4 Repowering

The wind power projects initiated in the 1990s by MNRE comprised of turbines of 225/250 kW and hub height of around 30–40 m. These are very low compared with current technologies and capacities available. As hub heights are directly related to the amount of wind power that is actually generated, such low heights lead to under utilisation of wind potential. It is estimated that over 3000 MW capacity installation are from wind turbines of around 500 kW or below.

Most of the turbines installed over the years are now nearing the end of their useful lifetimes. In order to effectively utilise the resource, MNRE has released the policy for repowering wind power projects. The refurbishment involves replacing old machines with fewer, larger and taller modern units, which are quieter, more reliable and can produce more electricity.

There are two approaches to repowering: full and partial. Full repowering involves removing the old turbines including foundations and replacing with new units. The more popular partial repowering typically involves an upgrade with more advanced and efficient technology to main components, particularly the rotor and gearbox, while other elements, such as the foundation and tower are retained for reuse. Partial repowering is the more complex, since the foundation — a technically complicated component that is buried under the ground — can be just as difficult to modify as it is to replace

### 9.5.5 Small-scale wind turbine

Wind turbines range in power output from a few Watts to tens of megawatts. A wind turbine with rated capacity of less than or equal to 100 kW is considered as a small wind turbine (SWT) in India.

The basic operating principles are the same for turbines of all sizes, such as restriction on output power as given by Betz limit, operational issues namely starting performance, cut-in



speed (the lowest wind speed at which power is extracted). These issues are however important for small machines:

- Small wind turbines are often located where the power is required or adjacent to the owner's home which may not be the best wind location, whereas wind farms containing large turbines are deliberately sited in windy areas.
- The generators of small turbines often have a significant resistive torque that must be overcome aerodynamically before the blades will start turning. Also pitch control is rarely used on small wind turbines because of cost.

### **9.5.7 Small Wind–Solar Hybrid System**

One of the major drawbacks of both wind and solar farms today is that power is produced only during certain intervals—when the sun shines during the day, or when there are strong enough winds, typically during the evening.

Superimposition of wind and solar resource maps in India shows that there are large areas where both wind and solar have high to moderate potential. The existing wind farms have scope of adding solar PV capacity and similarly there may be wind potential in the vicinity of existing solar PV plant.

The combination of renewable energy sources, wind & solar are used for generating power called as wind–solar hybrid system. This system is designed using solar panels and small wind turbines generators for generating electricity. A wind-solar plant will be recognized as hybrid plant if the rated power capacity of one resource is at least 25% of the rated power capacity of other resource.

A hybrid project reduces this variation and power can be generated from a plant almost 15–18 hours/day apart from optimally utilizing the infrastructure including land and transmission system.

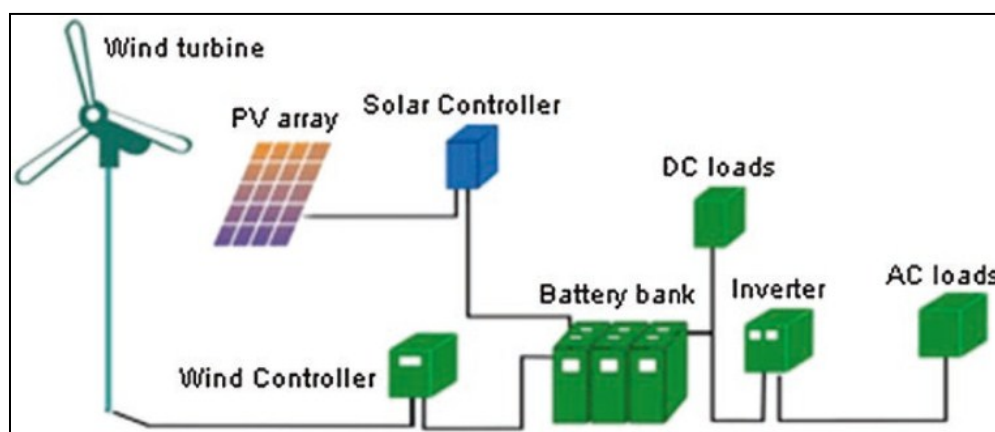
The hybrid plants allow power producers to tap into multiple energy sources simultaneously, and generate more power from a given site. A hybrid wind–solar system is ideal for remote location, as the system is normally a stand-alone system—not connected to the grid. For the times when neither the wind nor the PV is functioning, hybrid systems can provide power through batteries and/or a DG set. If batteries run low, DG set can provide power and recharge the batteries.

The various approaches towards integrating wind and solar are AC integration and DC integration.

In AC integration, the AC output of the both the wind and solar systems is integrated either at LT side or at HT side. In the later case both system uses separate step - up transformer and HT

output of both the system is connected to common AC Bus-bar. Suitable control equipment are deployed for controlling the power output of hybrid system.

DC integration (Figure 9.20) is implemented in case of variable speed drive wind turbines using convertor - inverter. In this configuration the DC output of the both the wind and solar PV plant is connected to a common DC bus and a common invertors suitable for combined output AC capacity is used to convert this DC power in to AC power.



**Figure 9.20: Hybrid Wind-Solar Power System**

## 9.6 Bio-energy

The organic matter that makes up the plants is known as biomass. Biomass can be used to produce electricity, transportation fuels, or chemicals. The use of biomass for any of these purposes is called bio-energy.

Biomass is basically 'fresh' carbon from plants and animals, while coal, oil and natural gas are more like 'old' carbon from plants and animals. Biomass is formed on a relatively short time-scale via photosynthesis from  $\text{CO}_2$  and water. The  $\text{CO}_2$  is released during combustion, and can then be bound by the next generation of plants. Therefore, biomass can be considered as a 'carbon neutral' fuel.

Bioenergy is a versatile energy source. In contrast to other energy sources, biomass can be converted into solid, liquid and gaseous fuels. Energy from biomass can be extracted by direct combustion, co-firing, gasification, bio-methanation or digestion.

### 9.6.1 Direct Combustion of Biomass

In direct combustion, biomass is burnt as a coal substitute or in a boiler. Biomass particles are first pre-treated to make the biomass easier to mill. For larger-scale combustion, fluidized bed reactor systems are used. This reactor type allows feeding of larger biomass particles up to the order of several centimetres. With fixed bed or moving bed reactors, large biomass particles can

be combusted. Air for combustion is distributed from bottom. These systems are also used for waste incineration and typical operating temperatures are above 1000°C.

### 9.6.2 Co-firing of Biomass

Co-firing of fossil fuels and various types of biomass is a mature technology and is currently being successfully practiced globally. With technological advances, many limitations associated with it have been overcome. Coal-fired plants can be converted or retrofitted to accommodate biomass co-firing with limited impact on efficiency, operations, or lifespan.

Various technologies have been developed to enable co-firing biomass with coal in pulverized coal (PC) boilers. The vast capacity of existing PC boilers offers great potential for increasing biomass utilization and economic benefits compared to new stand-alone power plants,

### 9.6.3 Biomass Gasification

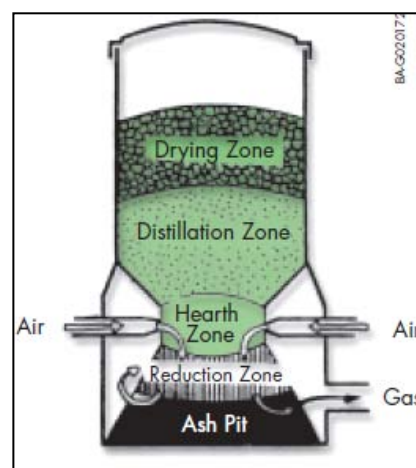
Biomass gasification is a thermo-chemical conversion of biomass into a combustible mixture through partial combustion route with air supply restricted to less than that theoretically required for full combustion. The output from the gasifier is also known as producer gas or syngas. A gasifier system basically comprises of a reactor where the gas is generated, and is followed by a cooling and cleaning unit which cools and cleans the gas. In the process, tar residues are also produced.

Producer gas consists primarily of carbon monoxide, hydrogen, carbon dioxide, and nitrogen, and has a heating value of 4 to 6 MJ/Nm<sup>3</sup>, or 10 to 15 percent of the heating value of natural gas. The heating value of the produced gas depends on the nature of the biomass and the gasification process. The produced gas can be burned directly in boilers, or it can be used as a fuel in engines or gas turbines after removal of tar.

There are two types of biomass gasification technologies—fixed bed or fluidized bed—both based on direct combustion. Small-scale gasifier capacities range from 5 kg/hour up to about 500 kg/hour of biomass input.

In fixed-bed gasifier reactors, the biomass is injected into the top of the unit. There are two methods to provide air for the gasification process namely updraft gasifier and downdraft gasifier. The downdraft gasifier is preferred because less tar residues is produced.

In downdraft gasifier, air and biomass move in the downward direction (Figure 9.21). The synthesis gas exits at the



**Figure 9.21: Downdraft Gasifier**

bottom of the reactor. The amount of tar produced is smaller than in the updraft method because of high temperature in the hot zone, around  $1000^{\circ}\text{C}$ , which causes tars to be broken down into lighter gases without affecting its energy content. Therefore tar content is much less than updraft gasifier.

In fluidized-bed gasifiers, a mixture of air, biomass particles, and inert bed materials undergo drying, pyrolysis, and gasification at high temperatures. The gasification process is more efficient due to the better heat transfer between the gas and the solid phases in fluidized state. Since this system operates at high temperature, a part of the tar undergoes cracking. The advantage of fluidized bed gasifiers compared to fixed ones are their higher capacities, the possibilities of using wide variety of biomass fuels, and even wet biomass.

#### 9.6.4 Anaerobic Digestion

In anaerobic digestion (also called as bio-methanation), biomass such as manure, sewage sludge and liquid waste is broken down by microbes at optimum temperatures (atleast  $35^{\circ}\text{C}$ ). This process is called as anaerobic which means without air. A biogas digester should produce  $200\text{--}400\text{ m}^3$  of biogas per dry ton input containing  $55\text{--}70\%$  methane, which means around  $8\text{ GJ}$  per ton input, for producing heat or generating electricity. Although, heat value of gas is less than the energy content of dry dung or sewage, the process produces clean fuel and disposes of odorous waste.

The predominant design in India is the floating-cover digester (Figure 9.22), which was introduced commercially by the Khadi and Village Industries Commission (KVIC).

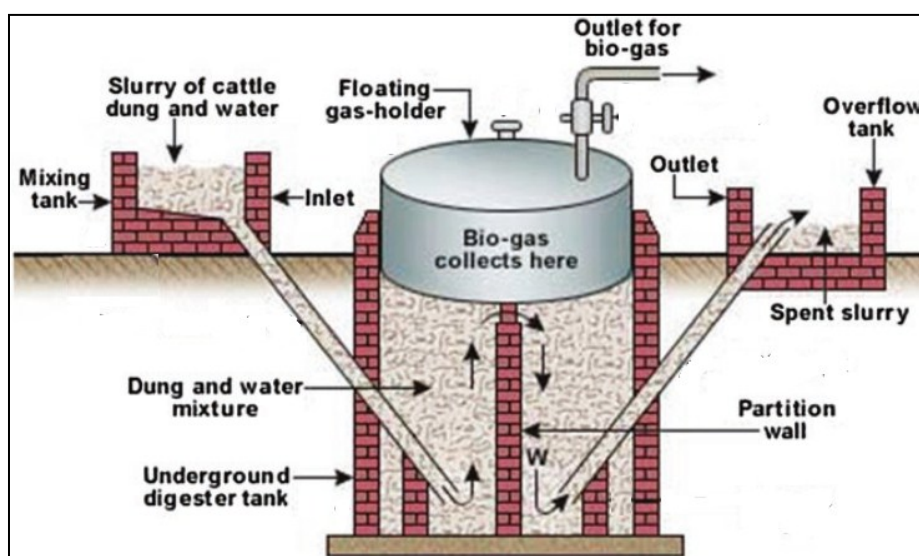


Figure 9.22: Anaerobic Digestion

With this design (Figure 9.2.2), a gas holder floats on a central guide and provides constant pressurisation of the produced gas. The reactor walls generally are brick or concrete, and the cover is made of mild steel. The digester is fed semi-continuously, with input slurry displacing an equivalent amount of effluent sludge. The predominant feed for digesters is a mix of cattle dung and water. The gas production rate is expressed in terms of daily volumetric gas production per unit of digester volume. The residual sludge can be used as an organic manure for gardening.

The wastes from following industries/sources can be bio-digested to produce biogas:

- Distilleries & Breweries.
- Sewage Treatment Plants (Municipal solids, liquids & Landfills).
- Food & Agro Processing Units (Starch, Palm Oil & Food processing Units).
- Dairy

**Typical Composition of Biogas:**

- Methane – 55 to 70%
- Carbon dioxide – 15 to 40%
- H<sub>2</sub>S – 1000 to 35,000 ppm
- Humidity – 100%
- Calorific Value – 4500 to 6500 KCal /m<sup>3</sup>

**Application**

H<sub>2</sub>S quantity has to be reduced to less than 200 ppm using a scrubber before use. The biogas can be burnt directly as a fuel for cooking or heating, or it can be used in a DG set for producing electricity. Alternatively, it can be used in a waste heat boiler to produce low pressure steam. In industries such as Dairy and Starch, where large quantities of refrigeration are needed, the biogas can be used as the heat source for an absorption refrigeration system.

in a Vapour Absorption Machine (VAM Chillers).

**Some thumb-rules for biogas generation are:**

- 10 kg of organic kitchen waste yields 1 m<sup>3</sup> of biogas
- 25 kg of cow-dung yields 1 m<sup>3</sup> of biogas
- 1 m<sup>3</sup> of biogas is sufficient for cooking requirements of a family per day

### 9.6.5 Liquid Biofuels

The biomass can also be used to make petroleum substitutes or alternative fuels which are called as biofuels. The main biofuels are ethanol and biodiesel. Ethanol can be used as a direct petrol substitute in some vehicles, but it can also be blended with petrol to be used in a typical car.

Biodiesel is produced from vegetable and animal fats. Depending upon the source of the feedstock, different qualities of biodiesels are produced. Vegetable oils are the easiest to source

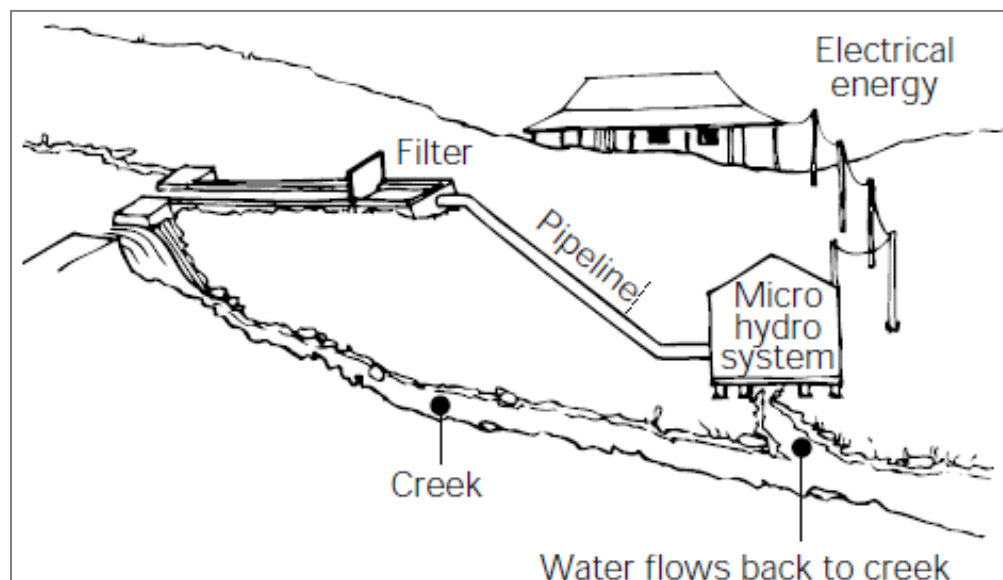
as suitable energy crops can be harvested and processed as biodiesel. Biodiesels can be blended with regular diesel for use in regular vehicles or used as a direct substitute in modified vehicles.

The National Policy on Biofuels, which was approved on 2008, aims to ensure that a minimum quantity of biofuels is readily available in the market in order to meet the demand at any given time. A target of 20% blending of biofuels, including biodiesel and bioethanol was proposed in 2017. However, implementation has not matched with the target. Ethanol production depends on sugar cane production in India. Hence the blend targets were partially successful in years of surplus sugar cane production.

### 9.7 Small-scale Hydropower

Small-scale or micro hydro units convert the energy of flowing water into electrical energy. With a suitable water source, micro hydro is the most cost effective form of renewable electricity. Micro hydro power is the best choice where water supply is continuously available.

In the run-of-river hydro (Figure 9.23), the natural flow of water is strong enough to power the hydro turbines with small height difference. Even resources with low heads of 2 to 10 metres are being exploited for producing power. They create less environmental impact than conventional hydro units because the natural flow of the river is only partially blocked.



**Figure 9.23: Run-of River Hydro**

The major advantages of small-scale hydro are their high reliability and high efficiency. Efficiency ranges from 70–75%, which means that 70–75% of the potential energy can be converted to electricity.

Micro or pico hydro generators operate with power outputs that are generally less than 5 kW. For small-scale hydro, micro and pico category, low head turbine design based on Archimedean screw which can be applied to 1 to 10 metre head difference and low flow rates of between 0.01 to 10 cubic metres per second are being used.

### Power generated by hydropower station

Electricity generation in hydropower requires height differences, or head, and flowing water. To calculate the power generated by a hydropower station, the following formula is used.

$$P = \eta\rho Qgh$$

Where,

P = power (W)

$\eta$  = efficiency of hydropower station

$\rho$  = density of water ( $\text{kg/m}^3$ )

Q = flow rate of water ( $\text{m}^3/\text{s}$ )

g = acceleration due to gravity ( $\text{m/s}^2$ )

h = height difference between the top reservoir and bottom reservoir, or Head (m)

### Example

The hydropower unit has a head of 10 metres and handles flow of 0.17 cubic metres of water every second. The turbine operates at an efficiency of 90%. The reference density of water,  $1000 \text{ kg/m}^3$ , and the acceleration due to gravity,  $9.81 \text{ m/s}^2$ . The power developed by the turbine:

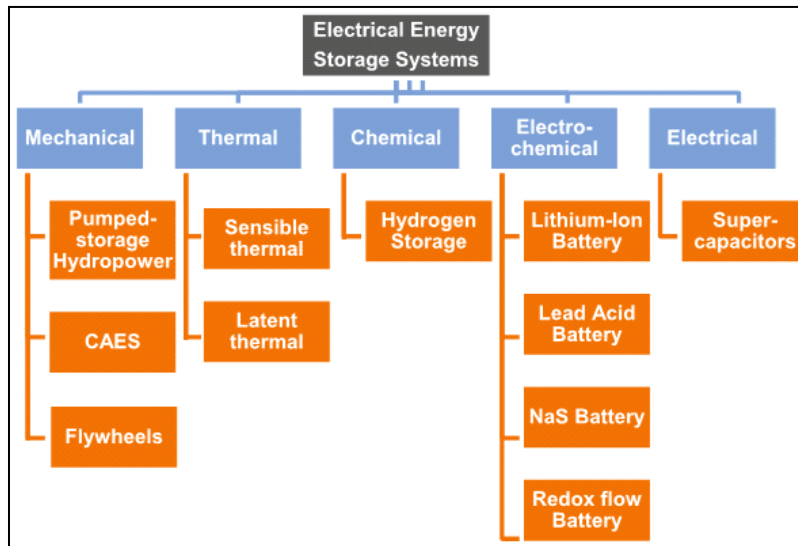
$$\begin{aligned} P &= \eta\rho Qgh \\ &= 0.9 \times 1000 \text{ kg/m}^3 \times 0.17 \text{ m}^3/\text{s} \times 9.81 \text{ m/s}^2 \times 10 \text{ m} \\ &= 15009.3 \text{ kg}\cdot\text{m}^2\cdot\text{s}^{-3} \\ &= 15009.3 \text{ or } \sim 15 \text{ kW} \end{aligned}$$

## 9.8 Electrical Energy Storage (EES)

With the planned integration of nearly 160 GW of wind and solar energy by 2020, there is a need for storage applications to address the issues of variability, unpredictability and location dependency of these renewable energy sources.

With developments such as distributed generation and smart grid, there is need to store electricity where it is needed. Due to recent developments in storage technologies and developments, electricity can be stored in megawatt scale. These electricity energy storage (EES) applications are increasingly becoming viable around the world.

Energy storage technologies are broadly classified into mechanical, electrochemical, chemical, electrical and thermal energy storage systems as shown in Figure 9.24.



**Figure 9.24: Electrical Energy Storage (EES)**

**Pumped storage hydro:** It is the most successful energy storage systems due to their fast response and storage capacity. Water is pumped during off-peak hours from lower reservoir to upper reservoir. Water is allowed to flow back from upper reservoir to run a turbine and generate electricity when required. The long lifetimes and stability makes them the ideal storage systems.

**Compressed air energy storage (CAES):** This technology is based on the conventional gas turbines and stores energy by compressing air in an underground storage. Electricity is used to compress air and when needed the compressed air is mixed with natural gas, combusted and expanded in a modified gas turbine. The turbine produces the same amount of output power as conventional gas turbines but uses only 40% of the gas. The advantage of CAES is its large capacity; disadvantages are low round-trip efficiency and geographic limitation of locations where it can be installed.

**Flywheels:** Kinetic energy is stored in a large rotational cylinder where the energy is maintained by keeping its speed constant. A transmission device is used to accelerate or decelerate the flywheel by supplying and extracting electricity. When the speed is increased higher amount of energy is stored. Flywheels are extensively used for space applications and latest generation flywheels are reported to be suitable for grid applications. The long life of this technology with relatively less maintenance requirements makes it another ideal storage solution. However, high levels of self-discharge due to air resistance and bearing losses may make it less efficient.

**Thermal storage:** These systems use chilled water, ice storage, hot water, molten salt as storage medium. The efficiencies vary with the material. These storage systems are becoming relevant for integrating large scale renewable energy such as concentrated solar thermal



technology which can be used as a reliable and despatchable source of energy to balance the supply and demand.

**Hydrogen:** Excess electricity from renewable energy can be used to produce hydrogen by electrolysis and therefore can be considered as zero-carbon fuel. Hydrogen can be stored as gas under pressure or liquid at low temperatures. It can then be used to create electricity in conventional reciprocating engines, gas turbines or in fuel cells, transport etc. A further area of application is that the hydrogen can be injected into existing natural-gas networks.

#### **Battery storage:**

Battery storage is a solution to the intermittency of renewable energy sources such as solar and wind. As battery costs continue to drop, battery storage will become an increasingly attractive option for storing electricity from such renewables.

**Lead acid batteries** are the world's most widely used battery type. Valve-regulated lead-acid (VRLA) batteries absorbed glass mat (AGM) designs have increased performance and total energy output making them a good choice for renewable energy off-grid applications at a lower cost than other batteries. However, their lifespan tend to be relatively short because of lower depth of discharge.

VRLA batteries with added nanocarbon are more resistant to sulfation which can reduce the life of batteries faster. The carbon slows sulfation and allows the battery to charge faster and cycle more than traditional lead acid.

**Lithium-ion batteries** are most popular as it powers the lives of millions of people each day ranging from laptops and cell phones to hybrids and electric cars. Lithium provides the highest energy density per weight--far lighter and more efficient than the popular lead acid battery. Lithium-ion batteries have a significantly higher cycle life than lead acid batteries in deep discharge applications. This means that lithium-ion battery can support a higher number of complete charge/discharge cycles before its capacity falls under 80%.

Lithium ion's high energy density and long cycle life has made it dominant in electric vehicle applications. Electric vehicles could also have an impact on energy storage through vehicle-to-grid technologies, in which their batteries can be connected to the grid and discharge power for others to use

**Sodium Sulfur (NAS) Battery** is a type of molten-salt battery constructed from liquid sodium (Na) and sulfur (S). This type of battery has a high energy density, high efficiency of charge/discharge and long cycle life. The operating temperatures of 300 to 350 °C and high corrosive nature of sodium makes it suitable only for large-scale grid storage applications. These batteries are ideally suited for supporting peak demand and stabilizing the grid.

**Redox (reduction–oxidation) flow** or a flow battery, or battery, is a type of electrochemical cell where chemical energy is provided by two chemical components dissolved in liquids contained

within the system and separated by an Ion exchange membrane accompanied by flow of electric current through the membrane. The major advantage over other rechargeable batteries is a long lifespan.

**Super Capacitor:** Capacitor is device which store current as static energy, rather than traditional storage of energy which uses a chemical reaction Super capacitors have a very high energy density (energy per unit volume or mass) than normal capacitors. Super-capacitors use two layers of the dielectric material separated by a very thin insulator surface as the dielectric medium, whereas normal capacitors use only a single layer of dielectric material

Unlike battery, a super capacitor can be re-charged indefinitely and do not have issues such as battery life, over-charging, and maintenance. The super capacitors can withstand much higher numbers of charge/discharge cycles and their response time is fast. They are ideally suited for very short-term power applications. However, the cost per unit of energy storage capacity is higher than for batteries.

## 9.9 RE–EE Integration for mitigation of Climatic Change

India is endowed with abundant renewable energy (RE) resources that currently supply about 5 percent of the country's grid electricity, with potential to enable a low-carbon growth path that can substantially strengthen the country's energy security and address climate change. However greater deployment of variable renewable energy (VRE) resources, like wind and solar poses challenges and costs for operating electricity systems. In this context it is important to answer the following two key questions if the country is to integrate its RE resources into the power grid at an accelerated scale.

- a) How can the issue of intermittence of RE resources and the need for load balancing be addressed?
- b) What are the emerging global best practices that countries are following to integrate their variable RE sources into the grid at a significant scale?

Some countries have been able to integrate significant levels of VRE into their power systems through improved methods for integrated planning and, deepening and broadening the application of demand side energy efficiency programs to contend with the intermittence of RE resources. The geographic concentration of India's RE resources – particularly wind – exacerbates existing transmission bottlenecks. Furthermore, much of India's new VRE generation is not covered by the most up-to-date power systems control technology, which prevents grid operators from visualizing the full extent of the challenge that they have to deal with. Current methods for power system analysis and planning do not permit a holistic approach to the design reforms in support of VRE integration. In particular the rigorous grid-integration

modeling used to build constituencies and support for increased RE targets in other countries is at its inception in India.

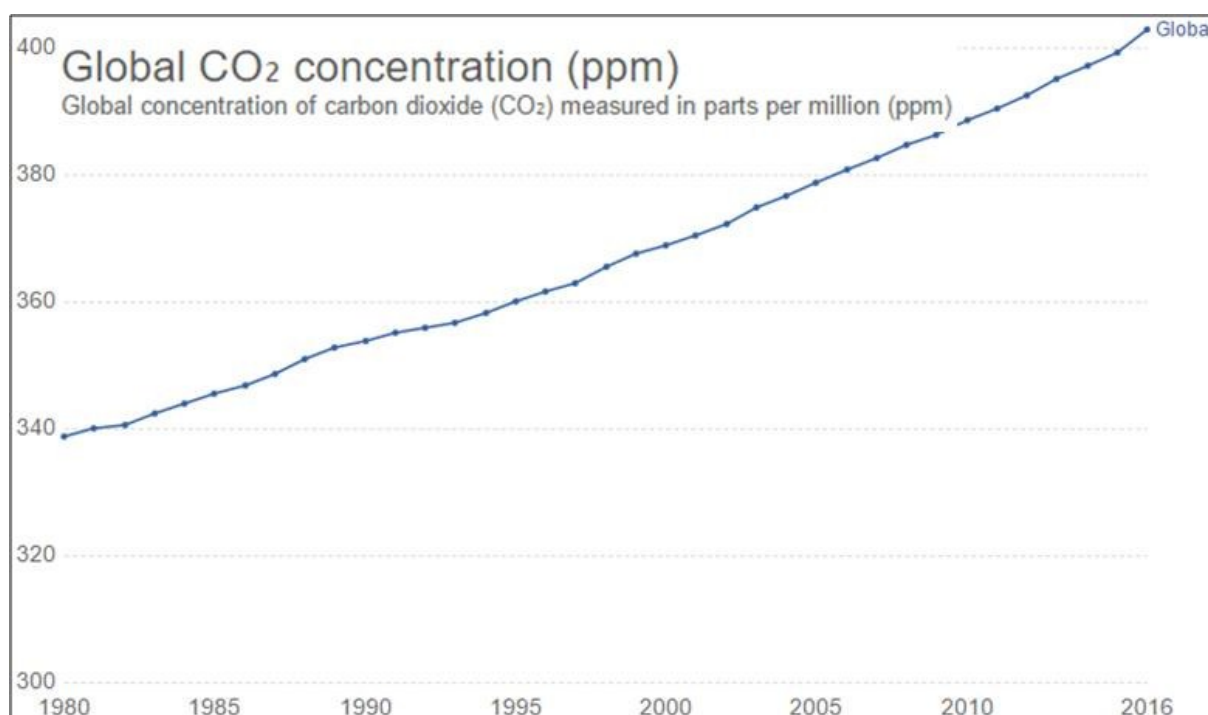
Efforts are underway to address some of the aforementioned issues of large-scale integration of RE into the power grid in India. They range from analysis and planning, policy and regulatory reforms, new infrastructure, and the application of utility driven demand response and efficiency programs. Key initiatives include the Government of India's (GOI) Smart Grid Roadmap and pilot projects in its distribution utilities, the reform of the Electricity Grid Code (particularly forecasting, scheduling, and managing system imbalances, and the application of demand side management/EE strategies) and a new process to prepare a roadmap for RE in India.

## 10. GHG AND CARBON FOOTPRINT ACCOUNTING AND REPORTING

### 10.1 Introduction to Greenhouse gases and Carbon Foot Print

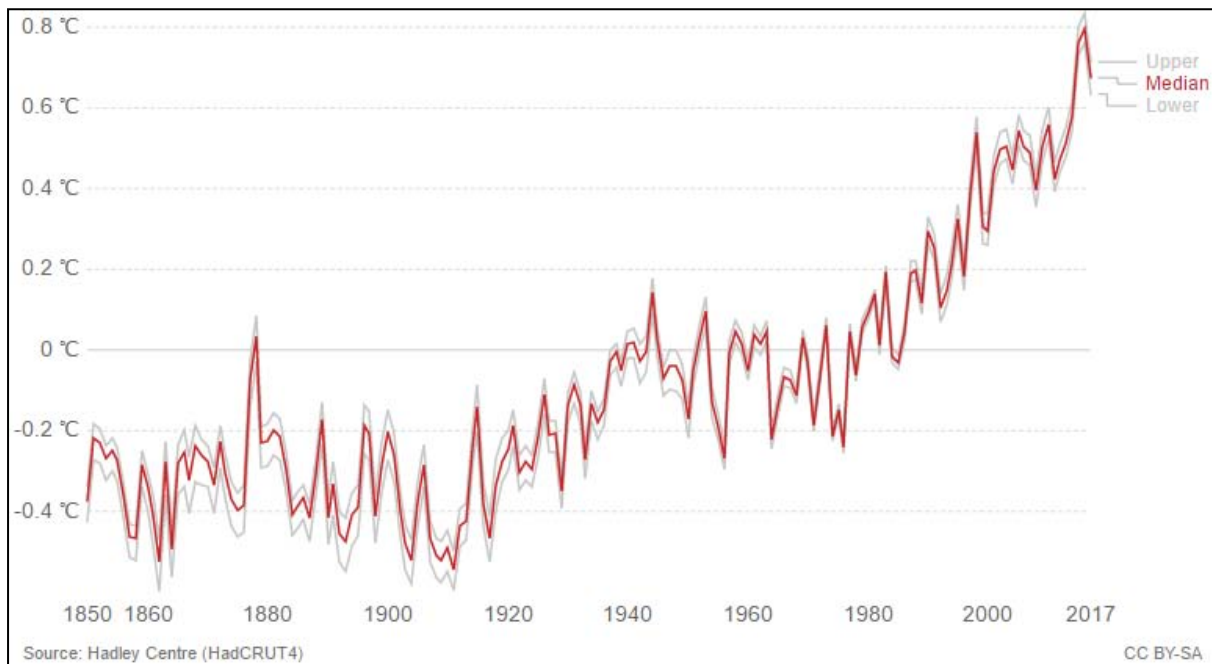
Human activities continue to impact Earth's climate through the emission of greenhouse gases. The climate change is caused by a range of gases, known collectively as 'greenhouse gases'. Six greenhouse gases (GHGs) contribute the most towards global warming and associated climatic change. They are carbon dioxide (CO<sub>2</sub>), methane (CH<sub>4</sub>), nitrous oxide (N<sub>2</sub>O), hydro-fluorocarbons (HFCs), per-fluorocarbons (PFCs), and sulphur hexafluoride (SF<sub>6</sub>). As concentration of these gases increase in atmosphere so will be the global warming. Over the last few decades, temperatures have risen sharply at the global level — to approximately 0.8°C higher than our 1961–1990 baseline. The global temperature is rising at the rate of 0.17°C per decade.

Of these greenhouse gases, most common is carbon dioxide released from combustion of fossil fuels such as coal, oil, natural gas etc. and that is why it is talked about the most. Figure 10.1 shows trend in CO<sub>2</sub> levels in parts per million (ppm) over the last four decades.



**Figure 10.1: Global CO<sub>2</sub> Concentration Increase Since 1980**

Figure 10.2 shows global average temperature increase as a result of increasing CO<sub>2</sub> levels.



**Figure 10.2: Global Average Annual Temperature Trend**

The term ‘carbon footprint’ is used to describe the amount of total greenhouse gas emissions caused directly and indirectly by a person, organisation, event or product. It is an approach for organizations and individuals to assess their carbon equivalent emissions i.e. all GHG converted to equivalent carbon emissions (CO<sub>2</sub> eq.). In other words, it is simply a unit for all GHGs expressed as if they had the same climate change effects as CO<sub>2</sub>.

At least 40 countries—both developed and developing—require facilities and/or companies that emit above a certain amount of greenhouse gas emissions to account and report their GHG emissions on an annual basis. In India, GHG Program is a voluntary initiative to standardize measurement and management of GHG emissions. The GHG reporting program has following benefits:

- It allows policymakers to better understand greenhouse gas emissions sources and trends.
- It can direct overall country climatic change policy
- It can collect data on energy production and consumption, which can steer energy efficiency policy development.
- It can be used by policy makers to set realistic, source-specific GHG reduction strategies.
- It can be used to assess which technology is more effective for GHG emission reduction so that mitigation strategies can be planned.
- It can lead to regular tracking of emissions and enable benchmarking.
- It enables industries to understand their emissions-related risks and opportunities so they can efficiently focus on mitigation activities that will produce the greatest GHG reductions.

The focus of this chapter is on GHG and carbon footprint accounting and reporting for an organization i.e. organization carbon footprint.

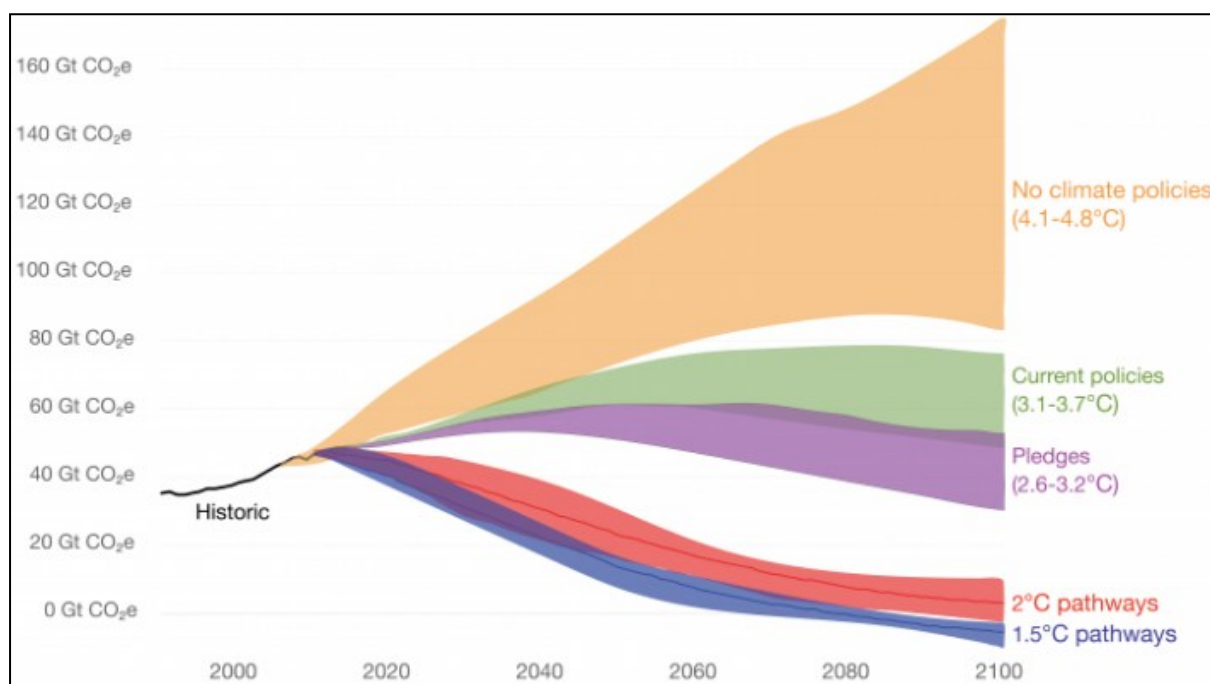
## 10.2 Global Greenhouse Gas Emission Scenarios

An increase of temperature beyond 2°C relative to pre-industrial levels is considered to be catastrophic. To mitigate the impacts of climate change, countries in the world entered into an international climate agreement at the U.N. Framework Convention on Climate Change (UNFCCC) organized Conference of the Parties (COP 21) in Paris in December 2015 to limit the temperature rise to 1.5°C, and to achieve net zero emissions in the second half of this century. The agreement envisages publicly stating their post-2020 climate actions they intended to take known as Intended Nationally Determined Contributions (INDCs).

INDCs reflect each country's goal for reducing emissions, taking into account its domestic circumstances and capabilities. Some countries also address how they will adapt to climate change impacts, and what support they need from, or will provide to, other countries to adopt low-carbon pathways and to build climate resilience.

The Paris climate agreement set actions to keep warming limited to 1.5–2°C by the end of the century. Potential future emission pathways of global greenhouse gas emissions (measured in gigatonnes of CO<sub>2</sub> eq. in the case of no climatic policies, current implemented policies, national pledges within the Paris Agreement, and 2°C and 1.5°C consistent pathways are shown in Figure 10.3. High, medium and low pathways represent ranges for a given scenario. Temperature figures represent the estimated average global temperature from pre-industrial to 2100. The five scenarios are shown in Figure 10.3.

- **No climate policies:** projected future emissions if no climate policies were implemented; this would result in an estimated 4.1–4.8°C warming by 2100 (relative to pre-industrial temperatures)
- **Current climate policies:** projected warming of 3.1–3.7°C by 2100 based on current implemented climate policies
- **National pledges:** if all countries achieve their current targets/pledges set within the Paris climate agreement, it is estimated average warming by 2100 will be 2.6–3.2°C. This will still be above the overall target of the Paris Agreement to keep warming "well below 2°C".
- **2°C consistent:** there are a range of emissions pathways that would be compatible with limiting average warming to 2°C by 2100. This would require a significant increase in ambition of the current pledges within the Paris Agreement.
- **1.5°C consistent:** there are a range of emissions pathways that would be compatible with limiting average warming to 1.5°C by 2100. However, all would require a very urgent and rapid reduction in global greenhouse gas emissions.



**Figure 10.3: Potential Future GHG Emission Pathways**

### 10.3 Indian GHG Scenario

India is the sixth largest economy in the world by nominal Gross Domestic Product (GDP) and third largest in terms of purchasing power parity. The per capita energy consumption is estimated to rise by about 5% annually till 2030. Under the business-as-usual scenario, the annual energy use per household is likely to increase to 2750 kWh by 2050.

The total GHG emission is about 2.34 billion tonnes of CO<sub>2</sub>/year which is about 7% of global CO<sub>2</sub> emissions<sup>1</sup>. Per-capita CO<sub>2</sub> emission is 1.84 tonnes (2016). India is quite vulnerable to the impacts of climate change. It is facing challenges which include water availability, changing rainfall patterns, and disaster management. It is difficult to quantify the expected impact of climate change. However, a recent World Bank study estimates that developing countries like India will need between \$70 and \$100 billion per year through 2050 to meet current and future climate adaptation needs.

India has committed to reduce its GHG emissions by 33-35% by 2030 compared to 2005 levels as its INDC commitments. These targets are planned to be met by identifying options to reduce or mitigate emissions while simultaneously meeting aspirations of achieving growth, maintain sustainable lifestyle and climate justice to protect the poor and vulnerable from adverse impacts of climate change. Accordingly the following focus areas are set as part of its INDC communication<sup>2</sup>.

- To reduce the emissions intensity of its GDP by 33–35% of the 2005 levels by 2030.

<sup>1</sup> BP Statistical Review of World Energy-2018

<sup>2</sup> Source : INDIA's INDC's target submitted to UNFCCC

- To achieve about 40% cumulative electric power installed capacity through non-fossil fuel sources by 2030 with the help of transfer of technology and low cost international finance including from Green Climate Fund (GCF).
- To create an additional carbon sink of 2.5 to 3 billion tonnes of CO<sub>2</sub> equivalent through additional forest and tree cover by 2030.

To implement the INDC targets, India's GHG emissions need to be measured, targets for reduction to be set and progress against these targets assessed and reported annually. However, under UNFCCC India do not have binding GHG mitigation commitments in recognition of its relatively small contribution to the greenhouse problem as well as low financial and technical capacities.

#### **10.4 GHG Accounting and Reporting**

When consolidating GHG data, it is important to distinguish between GHG accounting and GHG reporting. GHG accounting concerns the consolidation of GHG emissions from operations in which a company holds an operational or financial control and linking the data to specific operations, sites, geographic locations, and business processes. Accounting for emissions can help identify the most effective reduction opportunities.

GHG reporting, on the other hand, concerns the presentation of GHG data in appropriate formats to meet the needs of various reporting uses and users. As concerns over climatic change grow, NGOs, investors and other stakeholders are increasingly calling for greater corporate disclosure of GHG information. In response, companies are preparing stakeholder reports containing information on GHG emissions as a stand-alone report or as a part of broader sustainability reports.

#### **10.5 Relevant Protocols and Standards**

Two global approaches to organizational (sometimes called "corporate" or "entity-level") greenhouse gas accountings are available:

*The Greenhouse Gas Protocol (GHG Protocol)* was developed by a consortium convened by the World Resources Institute (WRI) and the World Business Council for Sustainable Development (WBCSD), and second revision is now available.

*ISO 14064-1:2006 Greenhouse gases -- Part 1: Specification with guidance at the organization level for quantification and reporting of greenhouse gas emissions and removals.*

It specifies principles and requirements at the organization level for quantification and reporting of greenhouse gas (GHG) emissions and removals. It includes requirements for the



design, development, management, reporting and verification of an organization's GHG inventory.

## 10.6 Estimating GHG or Carbon Emissions

GHG emissions or carbon dioxide equivalent emissions or simply carbon emissions refer to emissions of all GHGs stated in terms of tonnes of carbon dioxide equivalent (CO<sub>2</sub> eq). The carbon dioxide equivalent (CO<sub>2</sub> eq) allows the different greenhouse gases to be compared on a *like-for-like* basis relative to one unit of CO<sub>2</sub>.

CO<sub>2</sub>e is calculated by multiplying the emissions of each of the greenhouse gases by its 100 year global warming potential (GWP). The equivalence is based on Global Warming Potential (GWP) of each GHG and CO<sub>2</sub> is considered as common denominator with an equivalence of 1 and other GHGs are expressed in CO<sub>2</sub>e using their respective GWP. For example methane (CH<sub>4</sub>) has GWP is 28. Hence 1 kg CH<sub>4</sub> emissions equal 28 kg CO<sub>2</sub> eq. The GWPs for different GHGs are presented in Table 10.1.

**Table 10.1: GHG and its GWP**

GHG	GHG Name	Common Sources/Uses	GWP (100 year time horizon)
CO <sub>2</sub>	Carbon Dioxide	Fossil fuel combustion, forest clearing, cement production etc.	1
CH <sub>4</sub>	Methane	Coal mining, fuel combustion, landfills, wastewater treatment, production and distribution of natural gas and petroleum, etc.	28
N <sub>2</sub> O	Nitrous Oxide	Fossil fuel combustion, fertilizers, nylon production, manure, etc.	265
HFC's	Hydro fluorocarbons	Refrigeration gases, aluminum smelting, semiconductor manufacturing, etc.	Up to 12400
PFC's	Per-fluorocarbons	Aluminum production, semiconductor industry, etc.	Up to 11100
SF <sub>6</sub>	Sulfur hexafluoride	Insulated switch gears and circuit breakers.	23500

Source: GWP values for 100-year time horizon; IPCC fifth assessment report, 2014 (AR5)

In addition to major six Kyoto GHG gases, companies may also decide to report emissions data for other GHGs (i.e. Montreal Protocol gases) separately.

## 10.7 Calculations and Methods for Determining GHG Emissions

The following methods can be used to estimate GHG emissions:

- Measuring GHG emissions from identified sources and converting them to CO<sub>2</sub> equivalent using GWP.
- Measuring energy use and converting it to CO<sub>2</sub> equivalent using notified emission factors
- Estimating GHG emissions from production using product emission factors
- Estimating GHG emissions based on fuel consumed and its composition (ultimate analysis)
- Approaches for estimating GHG emissions from transport
- Estimating GHG emissions from chemical reaction using material balance

A brief description followed by illustrative calculation of GHG assessments by each of the above methods with examples are given as follows:

### 10.7.1 Measuring GHG emissions from identified sources converting them to CO<sub>2</sub> equivalent using GWP

An industrial source emits around 10 tonnes of CO<sub>2</sub> and 100 kg of methane. It also consumes around 0.2 kg of HFC. CO<sub>2</sub>e emissions using GWP can be estimated as shown in Table 10.2.

**Table 10.2: Estimation of Total GHG Emissions based on Emission Releases**

GHG gas emitted	Quantity	GWP	CO <sub>2</sub> eq
Carbon dioxide	10 t	1	10 t
Methane	100 kg	28	2.8 t
HFC	0.2 kg	12400	2.48 t
<b>TOTAL GHG EMISSIONS</b>			15.28 t

### 10.7.2 Measuring energy use and converting it to CO<sub>2</sub> equivalent using notified emission factors

For sources where there are difficulties in measuring emissions from source, such as due to use of fuels whose source of origin or quality is not known, or use of electricity produced using different fuels, for such GHG sources, emission factors that are published from various agencies like CEA can be used (refer Table 10.3).

**Table 10.3: GHG Emissions Factors**

S. No.	Parameter	Units	Emission Factor
1	Grid Electricity	Kg CO <sub>2</sub> /kWh	0.82
2	<u>CPP Electricity</u>		
a)	Coal Fired	Kg CO <sub>2</sub> /kWh	1.04
b)	Diesel Fired	Kg CO <sub>2</sub> /kWh	0.59
c)	Gas Fired (CC)	Kg CO <sub>2</sub> /kWh	0.43
3	Coal(Sub-bituminous)	Kg CO <sub>2</sub> /TJ	90600
4	Diesel	Kg CO <sub>2</sub> /TJ	69100
5	Furnace oil	Kg CO <sub>2</sub> /TJ	71900

Source: CO<sub>2</sub> Baseline Database for the Indian Power Sector, CEA, Dec 2014

As an example of how to estimate GHG emissions using these factors, assume an industry uses 950 kWh of grid electricity and 400 kWh of diesel-fired CPP electricity (DG set) and also uses 500 kg of furnace oil for heating purposes. The total CO<sub>2</sub>e emissions from the industrial source can be estimated as shown in Table 10.4.

**Table 10.4: Estimation of Total GHG Emissions based on Fuel/ Power Consumption**

Energy consumed	Quantity	Emission Factor, kg CO <sub>2</sub>	CO <sub>2</sub> e
Grid Electricity	950 kWh	0.82/kWh	779 kg
Diesel fired CPP electricity	400 kWh	0.59/kWh	236 kg
Furnace oil	500 kg	3.11/kg	1520 kg
<b>TOTAL GHG emissions</b>			<b>2535 kg = 2.54 t</b>

### 10.7.3 Estimating emissions from production using product emission factors

Standard GHG emissions data published by various government and other data agencies can be used to estimate the total GHG emissions. For example, in cement sector, the Energy Benchmarking for Cement Industry: Version 2.0, by CII; Cement Sector Emissions Calculation Tool India Version 1.0, July 2005 by TERI can be used. As an example, GHG emissions from cement industry producing 4 MTPA cement using specific GHG emission data could be calculated as shown in Table 10.5.

**Table 10.5: Estimation of Total GHG Emissions Based on Emission Factors**

Cement Production	Emissions, tCO <sub>2e</sub>		
	For Thermal energy	For Electrical energy	Total
1 ton	0.232	0.0604	0.2924
4 MTPA	928000	241600	1169600 = 1.17 MT CO <sub>2</sub> /year

#### 10.7.4 Estimating emissions based on fuel consumed and its composition (ultimate analysis)

The ultimate analysis of fuel e.g. coal can be measured to estimate the total GHG emissions as given in Table 10.6.

**Table 10.6: Ultimate Analysis of Sub-Bituminous Coal**

Element/Compound	(Weight %)
Carbon	39.17
Hydrogen	2.70
Oxygen	8.57
Nitrogen	1.16
Moisture	5.19
Mineral Matter	43.25
Sulphur	0.48

<b>Equation:</b>	C	+	O <sub>2</sub>	→	CO <sub>2</sub>
<b>Formula Wt.:</b>	12		32		44
<b>Tons emission per Ton carbon</b>	1				3.67
<b>Tons Emission per ton fuel</b>	0.39				1.43

For example, if the thermal power plant burns 1 tonne of coal, 1.43 tonnes CO<sub>2</sub> will be emitted.

#### 10.7.5 Approaches for estimating GHG emissions from transport

Three approaches are given for estimating GHG emissions from transport:

##### a) Calculating emissions based on fuel used and emission factor

Suppose total fuel used by all the diesel vehicles in a company is 150,000 litres annually. If the emission factor for diesel is 2.67 kg CO<sub>2eq</sub>/L, then

Total emissions = 150,000 x 2.67 = 400,500 kgCO<sub>2</sub> eq./year

**b) Calculating emissions based on fuel expenditure and emission factor**

The company does not collect fuel usage data. It tracks total fuel spend as INR 15 Lakhs/year. The average price for the year for diesel is INR.60/Litre.

$$\begin{aligned}\text{Fuel use} &= \text{Fuel spend} \div \text{Fuel price} \\ &= 1500000 \div 60 \\ &= 25000 \text{ Litres}\end{aligned}$$

Therefore:

$$\begin{aligned}\text{Total emissions} &= 25000 \times 2.67 \\ &= 66750 \text{ kgCO}_2 \text{ eq./year}\end{aligned}$$

**c) Calculating fuel use from mileage and fuel efficiency**

If the company does not have fuel expenditure data but know total mileage as 20000 km/year and estimates its trucks get mileage of 7 km/Litre. It therefore calculates its emissions as:

$$\begin{aligned}\text{Fuel use} &= \text{Distance} \div \text{Fuel efficiency} \\ &= 20000 \div 7 \\ &= 2857 \text{ Litres/year}\end{aligned}$$

Therefore:

$$\begin{aligned}\text{Total emissions} &= 2857 \times 2.67 \\ &= 7628 \text{ kgCO}_2 \text{ eq./year}\end{aligned}$$

**10.7.6 Estimating GHG emissions from chemical reaction using material balance approach**

Apart from combustion of fossil fuels, manufacturing of few products also emit GHGs. For example, in cement manufacturing process, calcium carbonate is thermally decomposed to form calcium oxide. The chemical equation is as follows:

Equation:	<b>CaCO<sub>3</sub></b>	<b>→</b>	<b>CaO</b>	<b>+</b>	<b>CO<sub>2</sub></b>
Formula Wt.:	100		56		44
Tonnes of Emission per Tonne CaCO <sub>3</sub>	1				0.44

If 1 tonne calcium carbonate is thermally decomposed, 440 kg CO<sub>2</sub> is released into the atmosphere.

**10.8 Carbon Footprints**

A carbon footprint measures the total greenhouse gas emissions caused directly and indirectly by a person, organisation, event or product. A carbon footprint considers all six of the Kyoto Protocol greenhouse gases.

The related terms are carbon neutral and carbon offset. A company becomes carbon neutral when its net greenhouse gas emissions become zero. To become carbon neutral, company

must calculate its emissions, reduce these emissions as much as possible, and purchase carbon credits equivalent to the remaining emissions which is called carbon offset. This process results in its balance emissions being offset and leads to net zero emissions or being carbon neutral.

Measuring the carbon footprint of products across their full lifecycle has following benefits:

- Identify cost savings opportunities
- Plan GHG emissions reductions
- Determine what level of emissions they need to offset to become carbon neutral
- Demonstrate environmental/corporate responsibility leadership
- Fulfill request from business or investors
- Meet customer demands for information on product carbon footprints
- Differentiate and meet demands from 'green' consumers (for improving marketing).
- Incorporate emissions impact into decision making on choosing suppliers, materials, product design, manufacturing processes, etc.
- Help meet national INDC targets

### 10.9 Types of Carbon Footprints

Broadly carbon footprint is assessed for organization as a whole (organizational carbon footprint) or for a product (product carbon footprint).

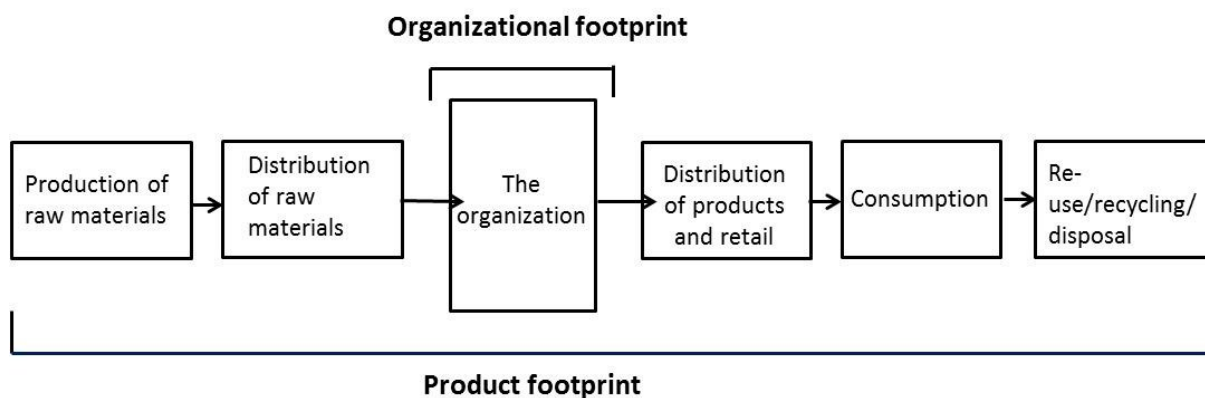
- Organizational carbon footprint

An organisational carbon footprint measures the GHG emissions from all the activities across the organization, including energy used in buildings, industrial processes and company vehicles. It measures both direct and indirect GHG emissions.

- Product carbon footprint.

A product carbon footprint measures the GHG emissions of the product over the whole life, from the extraction of raw materials, transportation to plant and manufacturing right through to its use and final re-use, recycling or disposal, or to the extent it controls the production, process based on boundaries it defines itself.

The different boundaries of organization and product footprints are illustrated in the Figure 10.4.



**Figure 10.4: The Different Boundaries of Organisational and Product Footprints**

### 10.9.1 Organizational Footprint

Of the two standards available to measure GHG emissions resulting from the activities of an organization for corporate GHG accounting, the Greenhouse Gas Protocol standard is most widely used.

#### ***The Greenhouse Gas Protocol Standard***

The Greenhouse Gas Protocol sets out how to account GHG emissions by categorizing emissions into three groups or 'scopes':

#### **Scope 1: Direct GHG emissions**

Companies report GHG emissions from sources they own or control as scope 1. Direct GHG emissions are the result of activities undertaken by the company.

- Generation of electricity, heat or steam. These emissions result from combustion of fuels in boilers, furnaces, turbines etc.
- Physical and chemical processing. These emissions arise from manufacture or processing of chemicals and materials, e.g. cement, aluminum, ammonia manufacture, and waste processing
- Transportation of materials, products, waste and employees. These emissions arise from the combustion of fuels in company owned/controlled mobile combustion sources (e.g. cars, buses, trucks, trains, airplanes etc.)
- Fugitive emissions. These emissions results from intentional or unintentional sources, e.g., leaks from joints, seals, packing and gaskets.

#### **Scope 2: Indirect GHG emissions**

Indirect emissions from any electricity, heat or steam purchased and used onsite. Although the emission is not under the control of the organization, by using the energy it is indirectly responsible for the release of CO<sub>2</sub>.

Purchased electricity represents one of the largest source of GHG emissions and most significant opportunity to reduce these emissions. Companies can reduce their use of electricity by investing in energy-efficient technologies and energy conservation.

Also renewable energy provides opportunities to switch over to less GHG intensive sources of energy. Company can also setup cogeneration plant and reduce electricity supply from grid which is more GHG intensive.

### **Scope 3: Other indirect emissions**

Any other indirect emissions from sources outside organisation direct control comes under scope 3. Scope 3 is optional, but it provides an opportunity to be innovative in GHG management. Examples of scope 3 emissions include transportation of purchased materials, purchased fuels and sold products, use of sold goods, employee commuting and business travel, outsourced transportation, waste disposal and water consumption.

Under the GHG protocol, all organizational footprints must include scope 1 and 2 emissions. There is flexibility when choosing which scope 3 emissions to measure and report. Typical activities covered under each are summarized in Table 10.7.

**Table 10.7: Activities Covered Under Each Scope**

<b>Scope 1</b>	<b>Scope 2</b>	<b>Scope 3</b>
Fuel combustion	Purchased electricity, heat and steam	Purchased goods and services
Company vehicles		Upstream transportation and distribution
Process emissions		Business travel
Fugitive emissions		Employee commuting
		Downstream transportation and distribution
		Use of sold products
		Fuel- and energy related activities

The scoping of emissions is illustrated in Figure 10.5.



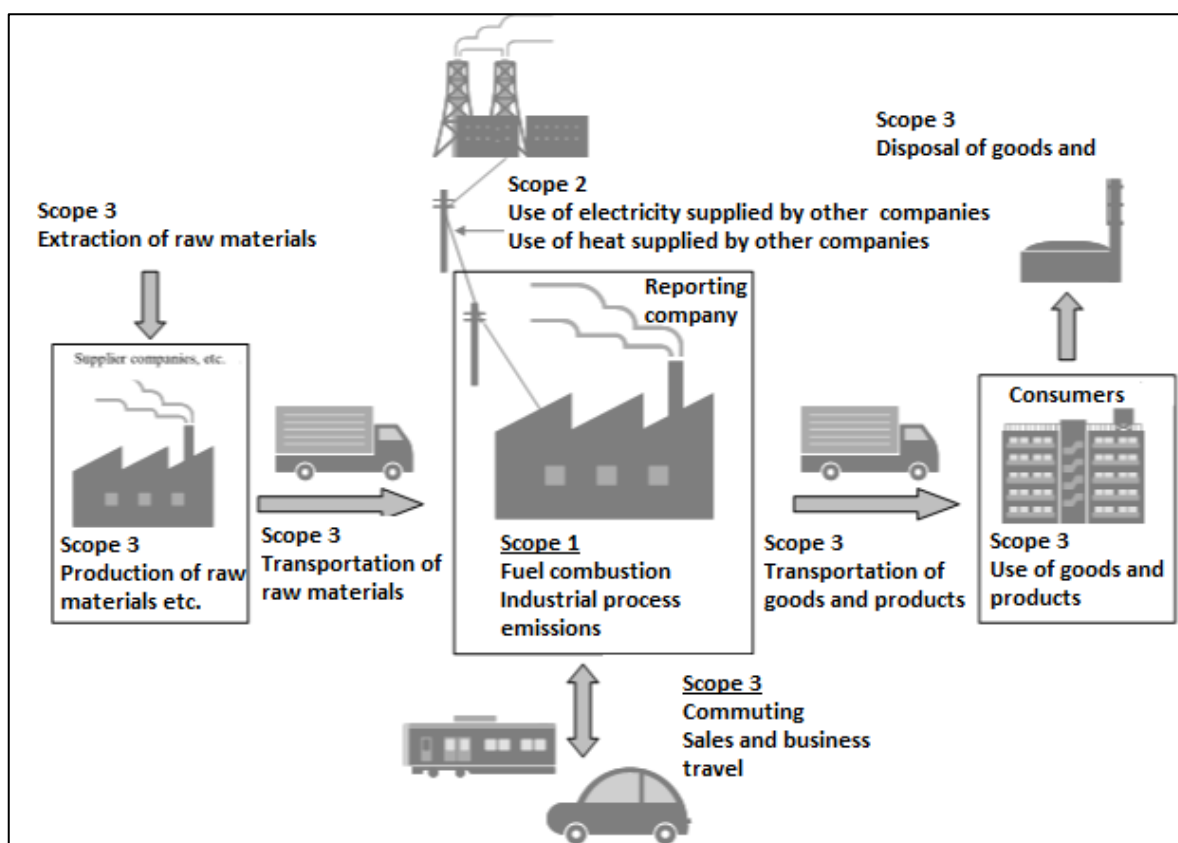
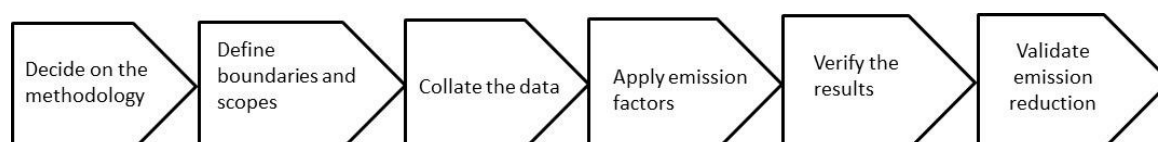


Figure 10.5: The Different Scopes of Carbon Emissions

### 10.9.2 How to calculate an Organizational Footprint?

The key steps in calculating an organizational footprint are:



#### ***Decide on the methodology***

The methodology used should be consistent as many people are involved in collecting and interpreting data. The GHG Protocol provides detailed guidance on methods, and is available free of charge online. The ISO 14064 on the other hand, which builds on many of the concepts introduced by the GHG Protocol.

Company shall choose and report a 'base year for which verifiable emission data are available. This will allow meaningful and consistent tracking of emissions over time.

In some areas the GHG Protocol leaves room for discretion, which may result in differences in which companies measure their emissions:

- It covers the 6 GHG of the Kyoto Protocol. In addition, companies may also provide emissions data for other GHGs (e.g., Montreal Protocol gases).

- When setting organisational boundaries, companies can choose between either the operational control or financial control criteria to consolidate GHG emissions.
- Companies are asked to separately account for, and report on scopes 1 and 2 at a minimum. Scope 3 is an optional reporting category.
- Companies are advised to choose as a base year as the earliest relevant point in time for which they have reliable data.
- The GHG Protocol recognizes the importance of a quality management system to ensure that an inventory continues to meet the principles of the GHG Protocol Corporate Standard and outlines five accounting principles that set an implicit standard for the faithful representation of a company's GHG emissions

Overall the two approaches are very similar in content and intent. A company reporting against ISO requirements could very well be informed by the GHGP guidance and context. In the majority of cases a company GHG report that meets ISO needs would also meet GHGP needs, and vice versa. The primary remaining area of difference regards treatment of indirect emissions.

### ***Define boundaries and scope***

Clear boundaries should be set which defines which parts of the organization are included in the footprint. For corporate reporting, companies shall account for and report their consolidated GHG data according to either the equity share or control approach.

Under the equity share approach, a company accounts for GHG emissions from operations according to its share of equity in the operation and equity share will normally be the same as the ownership percentage. Under the control approach, a company accounts for 100 percent of the GHG emissions from operations over which it has control.

If the reporting company wholly owns all its operations, its organizational boundary will be the same whichever approach is used.

The operational boundary determines which emission sources will be quantified. It should include the full range of emissions from activities under operational control. All scope 1 and 2 emissions should be included, but which of scope 3 emissions to include is left to choice.

### ***Collate the data***

The accuracy of the footprint relies on collating consumption data for all of the emission sources within the established boundary. For electricity, data in kilowatt hours (kWh) from meter readings or bills are used. The data for other fuels can be in a variety of units, such as litres, kWh or megajoules (MJ). For transport emissions, fuel consumption by fuel type where possible (from fuel cards etc) is taken. Where this is not available, consumption can be estimated based on the mileage of the vehicles and fuel economy assumptions.

### ***Apply emissions factors***

The carbon footprint is measured in tonnes of CO<sub>2</sub> equivalent (tCO<sub>2</sub>e), and is calculated using the activity data collated multiplied by standard emissions factors as given in Table 10.3.

***Verify the results (optional)***

The verification of the carbon footprint by a third party gives credibility and confidence to carbon reporting for public disclosure.

The companies may need to track emissions over time in response to various business goals such as,

- Public reporting
- Establishing GHG targets
- Managing risks and opportunities
- Addressing the needs of investors and other stakeholders

***Validating emissions reductions (optional)***

After measuring the carbon footprint and taking actions to reduce it progressively over time, organizational internal audit team or outside agency may be called to verify and certify to give credibility to the reduction claims. The approaches to validating results are as follows:

- Self-assessment
- Accredited third party Certification
- Non-accredited third parties Verification.

**10.9.3 Communicating organizational carbon footprint*****Internal communication***

Communicating organizational carbon footprint to employees can help engage them in the process of carbon reduction and energy management. If employees are asked to save energy, it is important to show them what difference they are making to the organization's emissions and the environment in general. The data collected may also help employees identify efficiencies in existing processes and practices.

***External communication***

The organizational carbon footprint is communicated externally as part of corporate social responsibility (CSR) report to demonstrate the concerns the business is having on the environment. For business-to-business organisations, many businesses may require suppliers to report emissions or at least demonstrate green credentials. A published and certified carbon footprint is a credible way of demonstrating this, particularly if it includes a carbon reduction plan, and can provide a company with a competitive edge. For business-to-customer organisations, consumers are increasingly taking environmental issues into account and publishing carbon footprints is a good way to give the customer confidence in the organization.

**10.10 Reporting GHG Emissions**

A credible GHG emissions report presents relevant information that is complete, consistent, accurate and transparent. A public GHG report should be based on the best data available at the time of publication. It should also communicate any material discrepancies identified in the previous years.

The *GHG Protocol Corporate Standard* requires reporting a minimum of scope 1 and scope 2 emissions.

### Required information

A public GHG emissions report that is in accordance with the *GHG Protocol Corporate Standard* shall include the following information:

### DESCRIPTION OF THE COMPANY AND INVENTORY BOUNDARY

- An outline of the organizational boundaries chosen,
- An outline of the operational boundaries chosen, and if scope 3 is included, a list specifying which types of activities are covered.
- The reporting period covered.

### INFORMATION ON EMISSIONS

- Total scope 1 and 2 emissions.
- Emissions data separately for each scope.
- Emissions data for all six GHGs separately in metric tonnes and in tonnes of CO<sub>2</sub> equivalent.
- Year chosen as base year, and an emissions profile over time
- Methodologies used to calculate or measure emissions
- Any specific exclusion of sources, facilities, and /or operations.

### Optional information

A public GHG emissions report should include, when applicable, the following additional information:

### INFORMATION ON EMISSIONS AND PERFORMANCE

- Emissions data from relevant scope 3 emissions activities for which reliable data can be obtained.
- Emissions data further subdivided, by business units/facilities, source types (stationary combustion, process, fugitive, etc.), and activity types (production of electricity, transportation, generation of purchased electricity that is sold to end users, etc.).
- Emissions from GHGs not covered by the Kyoto Protocol (e.g., CFCs, NO<sub>x</sub>), reported separately from scopes.
- Relevant ratio performance indicators (e.g. emissions per kilowatt-hour generated, tonne of material production, or sales).
- An outline of any GHG management/reduction programs or strategies.
- A copy of any verification statement, if applicable, of the reported emissions data.
- GHG emissions data for all years between the base year and the reporting year
- Information on the quality of the inventory (e.g., information on the causes and magnitude of uncertainties in emission estimates)
- A list of facilities included in the inventory.
- A contact person.

The above content of the report is adapted from the *GHG Protocol Corporate Standard*. The reader is advised to refer the standard for comprehensive details.

## A. ENERGY AUDIT INSTRUMENTS

### A1. Introduction

The conduct of an energy audit requires the use of portable instruments to monitor various electrical and thermal parameters.


The parameters typically monitored during energy audit may include the following:





- Electrical Parameters: Voltage (V), Current (I), Power factor ( $\cos\Phi$ ), Active power (kW), apparent power (demand) (kVA), Reactive power (kVAr), Energy consumption (kWh), Frequency (Hz), etc.
- Harmonics Parameters: The harmonic spectrum of currents and voltages (amplitudes and percentage of the fundamental), Total Harmonic Distortion (THD) % of Current and Voltage.
- Thermal Parameters: Temperature, heat flow, air and gas flow, liquid flow, moisture content, relative humidity, Combustion analyser for measurement of CO<sub>2</sub>, O<sub>2</sub>, CO, SO<sub>x</sub>, NO<sub>x</sub> etc.
- Other parameters: Lux, Total Dissolved Solids (TDS), noise vibration, Speed (RPM)





The energy audit instruments should be periodically calibrated as per the established schedule.





### A2. Typical Instruments Used For Energy Audit

The following are the major energy audit instruments used.


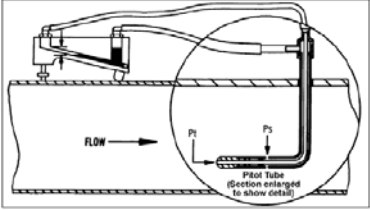



No.	Name of the Instrument	Features and Typical Applications
1.	<b>Power &amp; Harmonic Analyser</b> 	Measures all Electrical and Harmonic Parameters namely, V, A, PF, KW, kVA, kVAr, Hz, and first 50 Harmonics.  These instruments can be applied on-line i.e. on running motors without any need to stop the motor. Instant measurements can be taken with hand-held meters, while more advanced ones facilitates cumulative readings with printouts at specified intervals say every 1/2 hr over a shift or a day.



2.	<p><b>Tachometer (Contact-type)</b></p> 	<p>A tachometer is an instrument used to measure the rotational speed of a shaft or wheel in revolutions per minute (rpm). By measuring speed, energy auditor is able to find out belt slip if any and loading.</p> <p>A contact type tachometer can be used where direct access is possible.</p>
3.	<p><b>Non-Contact Tachometer / Stroboscope</b></p> 	<p>Non-contact tachometer allows the users to measure the rotational speed without contacting the object.</p> <p>Non-contact instruments are sophisticated and safer. These instruments can measure speed for objects that are visible but not accessible.</p> <p>A stroboscopic tachometer employs a variable-frequency, flashing light which makes the rotating component appear to stand still when the frequencies match.</p>
4.	<p><b>Lux meter</b></p> 	<p>A lux meter is a device for measuring illumination or lighting levels. The lux is a unit of measurement of illuminance (brightness).</p> <p>A lux meter works by using a photo cell to capture light. The light is then converted to an electric current and corresponding lux value.</p>
5.	<p><b>Combustion / Flue Gas Analysers</b></p> 	<p>Combustion analyser measures the composition of flue gases in percentage (% O<sub>2</sub> (or) % CO<sub>2</sub>), and flue gas temperature.</p> <p>The instrument estimates the combustion efficiency of furnaces, boilers and other fossil fuel-fired devices with an inbuilt programme.</p> <p>Two types are available: digital analyzers and manual combustion analysis kits. Digital combustion analysis equipment performs the measurements and reads out combustion efficiency in percentage.</p> <p>The manual combustion analysis kits typically require multiple measurements including exhaust stack: temperature, oxygen content, and carbon dioxide content. The efficiency of the combustion process can be calculated after determining these parameters. The manual process is tedious and is frequently subject to human error.</p>

6.	<p style="text-align: center;"><b>Thermometer</b></p>  	<p>These thermocouples measures temperatures of flue gas, hot air, hot water by insertion of appropriate probe into the stream. Different types include Fluid Filled, Resistance, Thermocouple and Thermistor.</p> <p>Most HVAC applications require a thermometer with temperature of <math>-50^{\circ}\text{C}</math> to <math>175^{\circ}\text{C}</math>. Boiler and oven stacks require thermometers able to measure up to about <math>500^{\circ}\text{C}</math>.</p> <p>By knowing the process temperature, the auditor can determine process equipment efficiency. It also helps us to waste heat recovery potential.</p> <p>For surface temperature, a leaf type probe is used with the same instrument.</p>
7.	<p style="text-align: center;"><b>Fyrite Gas Analyzer</b></p> 	<p>This instrument is used for measuring and analyzing carbon dioxide or oxygen. The instrument contains absorbing fluid which is selective in the chemical absorption of carbon dioxide or oxygen, respectively. Fyrite readings are unaffected by the presence of most background gases in the sample.</p> <p>Fyrite accuracy is sufficient for most industrial applications and test procedure is simple.</p>
8.	<p style="text-align: center;"><b>Infrared Thermometer (Non-contact type)</b></p> 	<p>The instrument is basically non-contact type which is able to measure temperature from a distance. Non-contact infrared thermometers, also known as heat guns, are very useful for measuring surface temperatures of steam lines, boiler surfaces, processes temperatures, etc.</p> <p>An infrared thermometer infers temperature from a portion of the thermal radiation sometimes called blackbody radiation emitted by the object being measured (as radiation is characteristic of their temperature). By knowing the amount of infrared energy emitted by the object and its emissivity, the object's temperature can be determined.</p> <p>The heart of the infrared thermometer is the detecting surface, which absorbs infrared energy and converts it to an electrical voltage or current.</p> <p>These instruments typically cover a range from <math>30^{\circ}\text{C}</math> to <math>2000^{\circ}\text{C}</math>.</p>
9.	<p style="text-align: center;"><b>Thermal Imaging Devices</b></p>	<p>Thermal cameras are instruments that create pictures of heat rather than light. They measure infrared (IR) energy and convert the data to corresponding images of</p>

		<p>temperatures.</p> <p>Non-contact infrared imagers provide fast, safe, accurate measurements for objects that are:</p> <ul style="list-style-type: none"> <li>▪ Moving or very hot</li> <li>▪ Difficult to reach</li> <li>▪ Impossible to shut-off</li> <li>▪ Dangerous to contact</li> <li>▪ Where contact would damage, contaminate or change temperature.</li> </ul>
10.	<p style="text-align: center;"><b>Ultrasonic Flow Meter</b></p> 	<p>Water and other fluid flows in pipelines can be easily measured using ultrasonic sensors mounted on the pipelines. This instrument is used to estimate the flow rates entering or leaving a pump. The meters are used to determine the fluid flow in terms of velocity and flow rate (given the diameter of pipe).</p> <p>This non-contact flow measuring device uses Doppler effect / Ultra sonic principle. A transmitter and a receiver are positioned on opposite sides of the pipe. Modes of operation and measurement are either by Doppler effect (or) Transit Time.</p>
11.	<p style="text-align: center;"><b>Thermo-anemometer</b></p> 	<p>This instrument is used for measuring air velocity in ventilation, air-conditioning and refrigeration systems etc.</p>
12.	<p style="text-align: center;"><b>Thermo-hygrometer</b></p> 	<p>This instrument measures humidity and temperature for determination of dew point and calculation of heat being carried away by out-going gases where product drying requires hot air.</p>
13.	<p style="text-align: center;"><b>Ultrasonic Steam Trap Tester</b></p>	<p>These instruments operate as electronic stethoscopes. They are able to pick up the very high-pitched sound indicative of freely blowing steam (condensate draining makes a lower-pitched sound).</p> <p>The advantage of ultrasonic testers is that they can</p>



		<p>listen to one pipe and detect if any of the nearby steam traps have failed.</p> <p>Ultrasonic detecting devices can also be used to identify any type of gas or fluid leaks e.g. compressed air leaks.</p>
14.	<p><b>Pitot Tube and manometer</b> <b>(Inclined /Digital manometer)</b></p>  	<p>Air velocity in ducts can be measured using a pitot tube and an inclined manometer for further calculation of flows.</p> <p>The principle is based on measuring the differential (velocity) pressure at various points (traverse points) across the cross-section of the duct.</p> <p>In addition to velocity pressure, this instrument can also determine Static and Total pressures.</p>
15.	<p><b>Leak Detectors</b></p>  	<p>Compressed air is one of the most costly utilities in a facility today. A simple program of leak inspection and repair helps greatly to reduce energy costs.</p> <p>Ultrasonic Leak Detector has an high quality flexible sensor is mounted on the end of a flexible steel pipe so the ultrasonic sound sensor can access hard to reach areas. The unit converts the ultrasonic noise of a leak into a sound a human can hear such as some beeping sound or LED display.</p> <p>Features of this instrument are</p> <ul style="list-style-type: none"> <li>• Detects the location of leaks</li> <li>• Detects almost any leak because <ul style="list-style-type: none"> <li>– Short distance/access not needed</li> <li>– High pressure not needed</li> <li>– Sensitive to sound</li> <li>– Filters background noises</li> </ul> </li> </ul> <p>This instrument does <u>not</u> measure the size of</p>

		the leak.
16.	<p><b>Conductivity Meter</b></p> 	<p>This instrument is used for spot analysis of the amount of total dissolved solids (TDS) in water especially in case of boiler blowdown. An accurate measurement of TDS is required to maintain blow down rate in boilers and optimize energy consumption.</p> <p>TDS meter measures the conductivity of the solution then converts that value to an equivalent TDS reading.</p>
17.	<p><b>pH meter</b></p> 	<p>pH meter is used for spot analysis of acidity or alkalinity of a solution/water..</p> <p>The meter uses the property of certain types of electrodes to exhibit electrical potential when immersed in a solution.</p>
18.	<p><b>Thermal Insulation scanner</b></p>	<p>This instrument measures loss of energy in kCal per unit area from hot/cold insulated surfaces. The total heat loss can be obtained by multiplying the value with total surface area.</p>

## Annexure B

## B. SOFTWARE AND SIMULATION FOR ENERGY AUDITING

### B1. Introduction

The use of energy audit software significantly decreases the time and costs of conducting energy audits, by standardising energy audit methodology, analysis and reporting across the organization. It also helps in preparing focused energy efficiency report.

The software-enabled study helps in identification of full range of energy efficiency options that are applicable with cost and benefit estimates. In recent years, cloud-based energy auditing software platforms are increasingly available

### B2. Applications of Various Softwares

There are many software applications in the form of Modelling, Simulation and Assessment tools available in the market for various utility systems. The brief use and applications of the select software tools that are used in the industries are given as follows:

#### Pumps

##### a. Pumping System Assessment Tool (Figure B1)

Main Inputs	Main Outputs
<ul style="list-style-type: none"> <li>• Electrical energy consumption (measured or nameplate)</li> <li>• Run hours</li> <li>• Static head (from drawings)</li> <li>• Discharges pressure (from pressure gauge)</li> <li>• Flow rate (from flow meter or estimate)</li> <li>• Average unit price (electricity)</li> </ul>	<ul style="list-style-type: none"> <li>• Motor, Pumping (Hydraulic) &amp; System energy efficiencies</li> <li>• Motor, Pumping &amp; Piping Losses</li> <li>• Total Energy Consumption &amp; Energy Cost</li> <li>• CO<sub>2</sub> Emissions</li> <li>• Energy Performance Indicators</li> <li>• Comparison of Actual Performance versus Best Practice</li> <li>• Performance Certificate</li> </ul>

**Software tools**

**Free download**  
**Available at**  
<https://www.seai.ie/resources/tools/Pump-Energy-Efficiency-Calculation-Tool-V7.xlsx>

**Figure B1: Pump Efficiency Calculations**

### b. Pump System Improvement Modeling Tool (PSIM)

PSIM which is highly graphical, drag-and-drop for centrifugal pump modeling tool (Figure B2) with following features:

- Pump sizing
- Variable speed drives
- Impeller trimming
- Best Efficiency Point (BEP) calculations
- NPSH calculations
- Viscosity correction to pump curves
- Power calculations
- Energy usage and cost
- Positive displacement pump modeling includes:
  - Generated head
  - Power calculations
  - Energy usage and cost
  - Ability to model flow and pressure control valves

- Generation of pump versus system curves (Figure B3)
- Ability to model different types of fluids
- Ability to model pipe networks with up to twelve pipe elements

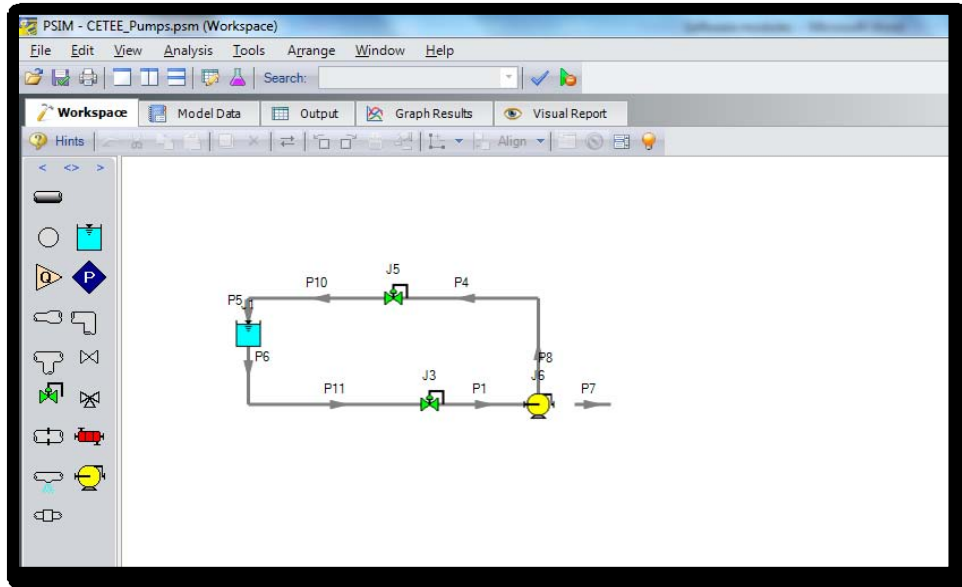


Figure B2: Model of Pumping System

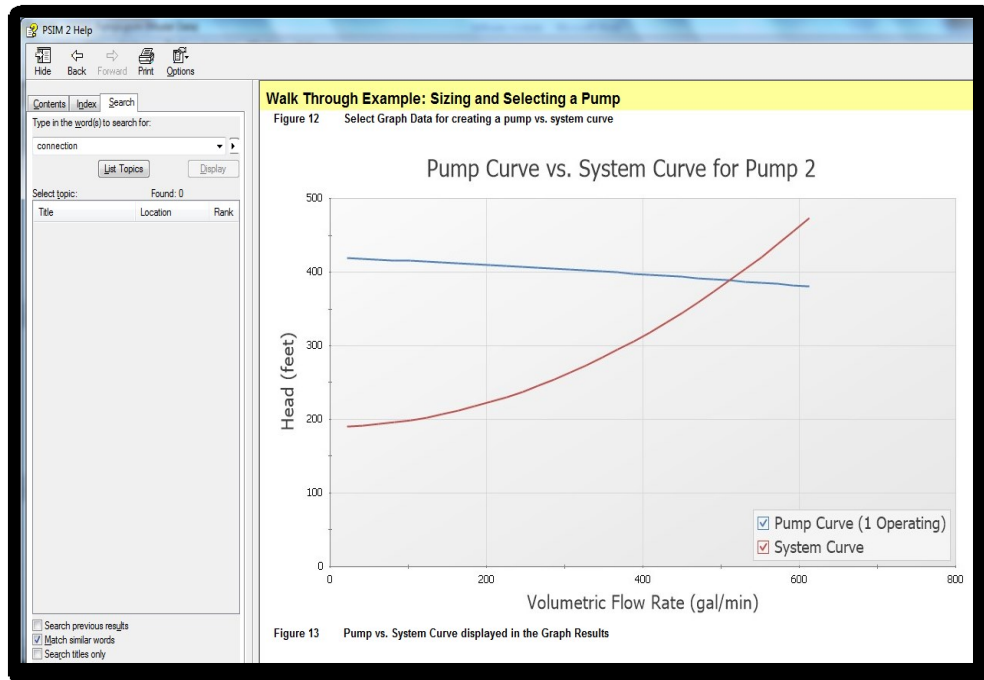


Figure B3: Results of Pump vs System Curve

## Building Simulation Software (ESim)

ESim is a building energy simulation tool used for design, commissioning, and retrofit analysis. Building energy simulation is performed using a computer to virtually represent a building design and perform physics based calculations. The simulations can range from a building component to a cluster of buildings. For energy simulation, the building model along with the usage pattern and weather of the location are required to determine various outputs, such as peak loads, system sizing, and energy consumption for any given period. This information can be used for estimating the utility bills, for evaluating cost–benefit analysis of various design strategies.

Some of the uses for energy simulation tools are:

- **Early design decisions:** In early design stage, decisions such as orientation and layout of the building are taken. Energy simulation can help in evaluating various design strategies. However, a detailed simulation may not be possible because of the limited information available at this stage.
- **Component or material selection:** Simulation helps in the decision-making process while selecting individual components of building envelope or systems. It can be used to carry out cost–benefit analysis of various designs and components. Modeling at this stage needs to be performed with greater accuracy as compared to modelling for early design decisions.
- **Retrofitting decisions:** For retrofit of existing buildings, energy simulation can help in selecting cost effective solutions. For an accurate analysis, simulation model should be calibrated using the measured performance data of the building.

The following basic information is required:

**Location and weather file:** Energy simulation tools need hourly ambient conditions (temperature, humidity, wind velocity, solar radiation, etc.) at the building location. This information is available in weather files. Simulation tools use these weather files to extract the hourly ambient conditions while carrying out the simulation. However, for some locations, the weather file may not be available. In such cases, the weather file of some other location with similar weather conditions can be used

**Building geometry:** Building elevation and floor plans are required to create the geometric model of a building. Architectural drawings may have many details that might not be directly useful for energy simulation. It is useful to simplify the drawings based on thermal zoning into a single line drawing by removing unnecessary details.

Envelope components: It is necessary to have construction details, such as thickness and thermal physical properties of materials used in each layer of building envelope. Besides the opaque components, it is very important to have properties of window glass, frame and shading devices.

**Building services:** Information about various services such as HVAC and lighting is required. This includes equipment capacities, energy efficiency, location and controls.

Usage of building; the hourly values of the following are required:

- Occupancy
- Lighting
- Equipment
- Thermostat set point
- HVAC operation

### **How Simulation Software Works?**

The simulation program enables simultaneous interaction of the geometric model with outdoor conditions, occupancy, and usage of building systems to predict various loads arising in the building on an hourly basis. Basic laws of physics and energy balance equations are used for calculations. The energy consumption for the operation of systems corresponding to the heat and other loads is also calculated on the same time scale. Results of the processing are passed to the calculations of next time slice and are also supplied to the output file. This process continues for the entire duration of the simulation, and the final output is seen as aggregated or on the same time slice for which calculation has been carried out. Most simulation tools are capable of simulating the energy flows through different building components on an hourly basis, including the transient effects of the envelope and systems.

Simulation software: DESIGN BUILDER

Website for purchase: <https://www.designbuilder.co.uk>

### **B3 Softwares for Process Plants, Power Plants, Solar Systems Refinery, Optimizing Heat Exchanger network, Steam plants, and other thermal systems**

#### **EBSILON**

EBSILON is a simulation system for thermodynamic cycle processes that is used for plant planning, design and optimization. It allows the benefits of repowering and retrofitting measures by simulating them.

It allows performance of the plant to be optimized for by introducing specific parameter. It allows calculations of the effects of component degradation, changes in load and changes in environmental conditions. It allows simulation of the operation of newly developed components in a cycle.

Any thermodynamic cycle can be modeled. The modeling options are available for conventional power plants, nuclear and solar power plants, desalination plants, fuel cell applications and so on.

Some of the features include,

- Intuitive modeling with graphical user interface
- Powerful calculation tools and solution algorithm
- Comprehensive component library
- Material data libraries for working fluids and fuels
- Comfortable analysis and presentation of results
- Open software architecture and powerful interfaces
- Intelligent error analysis and online help
- Expansion of the functionality by means of add-on modules

Website for purchase: <https://www.steag-systemtechnologies.com>

### **Thermoflex**

This is referred to as “heat balance software”. It is a fully flexible program with a graphic user interface in which the user creates a thermal system network by selecting, dragging, dropping and connecting icons representing over two hundred different components. The program covers both design and off-design simulation, and models all types of power plants, including combined cycles, conventional steam cycles, and repowering; as well as a wide range of renewable energy plants and systems. It can also model general thermal power systems and network.

Software for purchase: <https://www.thermoflow.com>

### **STEAM PRO**

This software automates the process of designing a conventional (Rankine cycle) steam power plant, guiding the user to rapidly and easily attain an optimal configuration including its technical parameters.



The user inputs design criteria, starting with the big picture and progressing in a logical sequence into greater details. Built-in expert logic automatically selects appropriate options and inputs for the various details, based on the user's high level selections. The program designs the new plant, computes its performance, its detailed heat and mass balance, and creates its major equipment physical sizes and design details.

Free

Website for download: <https://steam-pro.soft112.com/>

## STEAMMASTER

This software simulates performance of a given plant at different operating conditions, such as part-loads, feed water heater by-pass, different environmental parameters, etc.

The user may change the physical hardware of a radiant furnace, or a feed water heater, or a condenser, or a pipe, etc., to match vendor or final engineering specs. Steam Master is based on an Excel spreadsheet with a Visual Basic interface to simplify steam system characterization

Features of the Software:

General Features:

- Software accepts multiple boilers
- Four firing rates (and efficiencies) for each boiler
- Matches boiler furl use for multiple boilers and firing rates
- Visual Basic Interface

Combustion Efficiency

- ASME indirect method of calculating combustion efficiency
- Fuel properties lookup table that includes gas, oil, coal, and wood

Boiler Efficiency

- Part load efficiencies
- Radiation and convection losses that are important at part loads
- Cycling losses are also important at low loads

System Losses

- Uninsulated steam piping
- Steam leaks
- Trap leaks
- Flash steam

## Databases

- Boiler manufacturer specification database
- Steam trap manufacturer specification database

Calculates savings from five steam recommendations:

- Tune boilers
- Insulate steam pipes
- Repair steam leaks
- Repair trap leaks
- Recover flash steam

## TRNSYS

It is an extremely flexible graphically based software environment used to simulate the behavior of transient systems. The vast majority of simulations are focused on assessing the performance of thermal and electrical energy systems

TRNSYS is made up of two parts. The first part is an engine (called the kernel) that reads and processes the input file, iteratively solves, determines convergence, and plots system variables. The kernel also provides utilities that determine thermo-physical properties, invert matrices, perform linear regressions, and interpolate external data files.

The second part of TRNSYS is an extensive library of components, each of which models the performance of one part of the system. The standard library includes approximately 150 models ranging from pumps to multi-zone buildings, wind turbines to electrolyzers, weather data processors to economics routines, and basic HVAC equipment to cutting edge emerging technologies. Models are constructed in such a way that users can modify existing components or write their own, extending the capabilities of the environment.

## Applications

- Central plant modeling
- Building simulation (including LEED Energy Modeling)
- Solar thermal processes
- Ground coupled heat transfer
- High temperature solar applications
- Geothermal heat pump systems
- Coupled multi-zone thermal/airflow modeling
- Optimization
- Energy system research
- Emerging technology assessment
- Power plants (Biomass, Cogeneration)

- Hydrogen fuel cell systems
- Wind and Photovoltaic Systems
- Data and simulation calibration

Reference website for purchase: <http://www.trnsys.com/>

### **Engineering Equation Solver (EES)**

EES is a general equation-solving program that can numerically solve thousands of coupled non-linear algebraic and differential equations. The program can also be used to solve differential and integral equations, do optimization, provide uncertainty analyses, perform linear and non-linear regression, convert units, check unit consistency, and generate publication-quality plots. A major feature of EES is the high accuracy thermodynamic and transport property database that is provided for hundreds of substances that allows it to be used with the equation solving capability.

Reference website for purchase: <http://www.fchart.com/>

### **Aspen Energy Analyzer**

Aspen Energy Analyzer is energy management software for performing optimal heat exchanger network design to minimize process energy. The software is used to develop improved heat integration projects while significantly reducing operating, capital, and design costs, and minimizing energy-related emissions of heat exchanger networks. The purpose of the networks is to maximize heat recovery, thereby lowering the overall plant costs.

In process industries, during operation of any heat exchanger network (HEN), the major aim is to focus on the best performance of the network so as to optimize the given process and minimize the heating load and cooling load. This software implements a methodology for HEN synthesis with the use of pinch technology. Several heat integration networks are designed with different  $\Delta T$  min and total annualized cost compared to obtain the optimal design

Utilizing either a graphical or algorithmic method, users can identify the best heat exchanger network design solutions without spending excessive amounts of resources. It also provides an easy environment to perform optimal heat exchanger network design and retrofit. Using this tool, it is possible to cut down on unnecessary energy use, for a less expensive and greener process design.

Reference website for purchase: <https://www.aspentech.com>

## Compressors (AirSim)

AirSim is a compressed air simulation software tool, which is useful for estimating savings from various energy efficiency upgrades and control changes. AirSim is designed so that simulation outputs can be visually calibrated to measured energy consumption and pressure data. Once calibrated, system parameters can be changed to simulate expected compressor and system performance under various conditions.

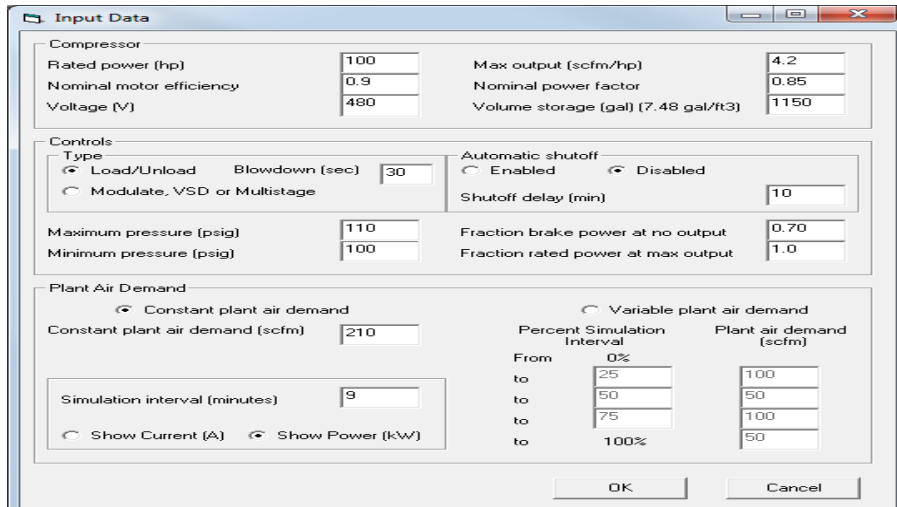
AirSim allows users to simulate multiple compressor systems with pressure band staging control or automatic sequencer control. Savings can be estimated as the difference between current and expected compressed air system energy use.

AirSim allows the user to simulate a compressed air system with multiple compressors using automatic sequencer control. AirSim uses basic control logic to determine which compressors operate based on the variable plant air demand, rather than the user having to specify the staging order for each hour using AirMaster+.

The AirSim sequence of operation begins by opening the program file. The user can choose to run a simulation on a compressed air system with one air compressor or multiple air compressors.

### Single Compressor Data Inputs

The AirSim single compressor input screen is shown in the Figure B4. The input screen allows the user to define the values of the key system parameters and to select how the outputs will be displayed. The inputs are divided into Compressor, Controls and Plant Air Demand sections.



Compressor	
Rated power (hp)	100
Nominal motor efficiency	0.9
Voltage (V)	480
Max output (scfm/hp)	4.2
Nominal power factor	0.85
Volume storage (gal) (7.48 gal/ft <sup>3</sup> )	1150

Controls	
Type	<input checked="" type="radio"/> Load/Unload    Blowdown (sec) 30 <input type="radio"/> Modulate, VSD or Multistage
Automatic shutoff	<input type="radio"/> Enabled <input checked="" type="radio"/> Disabled Shutoff delay (min) 10
Maximum pressure (psig)	110
Minimum pressure (psig)	100
Fraction brake power at no output	0.70
Fraction rated power at max output	1.0

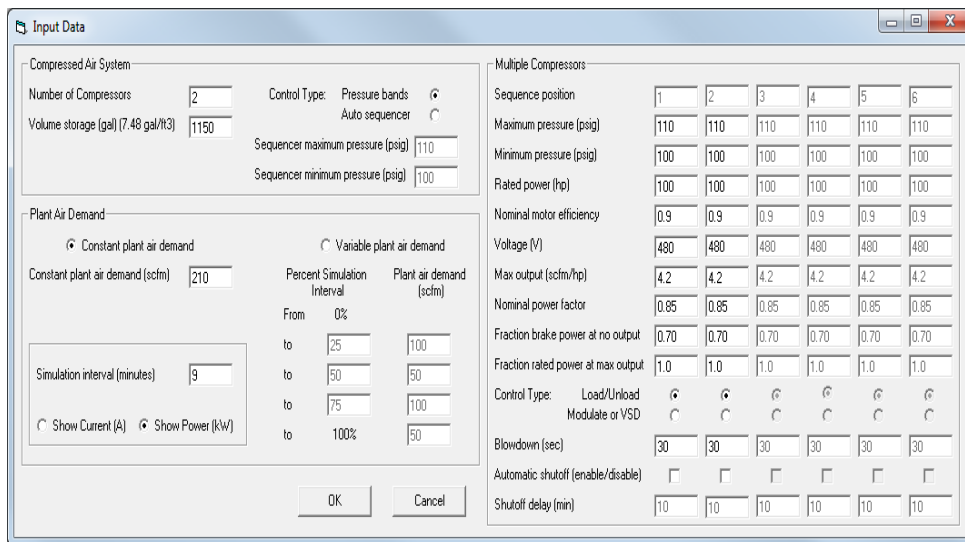
Plant Air Demand	
<input checked="" type="radio"/> Constant plant air demand Constant plant air demand (scfm) 210	<input type="radio"/> Variable plant air demand Percent Simulation Interval    Plant air demand (scfm)
Simulation interval (minutes) 9	From 0%    100 to 25%    50 to 50%    100 to 75%    100 to 100%    50
<input type="radio"/> Show Current (A) <input checked="" type="radio"/> Show Power (kW)	

Figure B4: Data Input

The compressor inputs	The controls inputs include	The plant air demand inputs
<ul style="list-style-type: none"> <li>✚ Rated power (HP)</li> <li>✚ Nominal motor efficiency</li> <li>✚ Supply voltage (V)</li> <li>✚ Maximum compressed air output (scfm/HP)</li> <li>✚ Nominal power factor</li> <li>✚ Volume of compressed air storage</li> </ul>	<ul style="list-style-type: none"> <li>✚ Control type (load/unload or modulate/VSD/multistage)</li> <li>✚ Blowdown time (seconds) – only activated if load/unload control type is selected</li> <li>✚ Optional air compressor automatic shutoff</li> <li>✚ Automatic shutoff delay time (minutes) – only activated if automatic shutoff is selected</li> <li>✚ Maximum compressor pressures (psig)</li> <li>✚ Minimum compressor pressures (psig)</li> <li>✚ Compressor brake power at no output</li> <li>✚ Compressor rated power at max output (sometimes referred to as a motor's service factor)</li> </ul>	<ul style="list-style-type: none"> <li>✚ Constant or variable plant air demand</li> <li>✚ Constant plant air demand (scfm)</li> <li>✚ Variable plant air demand load profile (percent time and scfm)</li> <li>✚ Simulation interval (minutes)</li> <li>✚ Graphical output display of current (A) or power (kW)</li> </ul>

**Multiple Compressors Data Inputs**

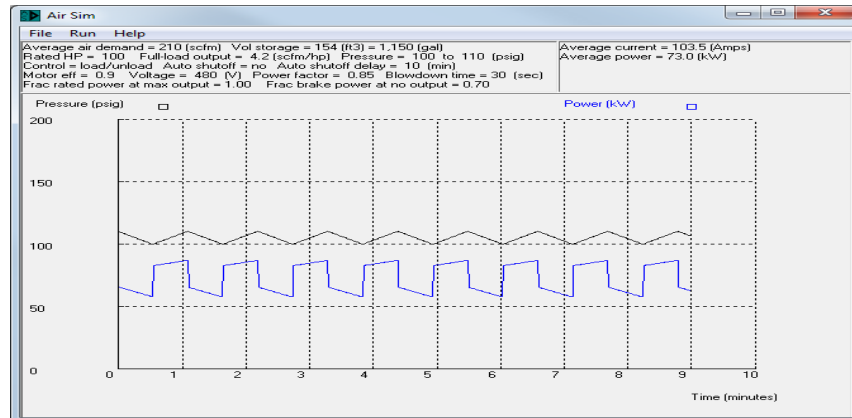
The AirSim multiple compressor input screen is shown in Figure B5. The input screen allows the user to define the values of the key system parameters and to select how the outputs will be displayed. The inputs are divided into compressed air system, plant air demand and multiple compressors sections.



**Figure B5: Data Inputs (Multiple Compressors)**

## Single Compressor Outputs

The output screen for the single compressor simulation is shown in Figure B6. AirSim displays key simulation inputs in the top left panel. AirSim also calculates the average current and average power over the simulation interval and displays these in the top right panel. The graphical display of the simulation interval includes the system pressure and power/current draw of the air compressor.



**Figure B6: Output Screen (Single Compressor Simulation)**

Free

Website for download: <https://www.airbestpractices.com/>

## ✚ Lighting (LightSim) - Natural Daylighting Simulation Tool

This software uses TMY (Typical Meteorological Year) or EPW (Energy Plus weather data) weather files as input. The hourly illuminance incident on windows and skylights is computed assuming that natural daylight has luminous efficacy of 110 lm/W. The hourly illuminance on the work plane of an interior space is computed using the IES method. The fraction of time that daylighting meets a target illuminance, and hence the fraction of time that electric lights can be turned off, is computed. These results support the design and economic evaluation of daylighting projects.

After each simulation, LightSim reports input data and annual simulation results. It reports the fraction of hours that illumination from daylighting meets or exceeds the target illumination on a monthly basis.

The fraction of hours that illumination from daylighting meets or exceeds the target illumination is an indication of the amount of time that all electric lighting in a room could be turned off.

However, sophisticated lighting controls may be able to turn off or dim a portion of the lights, even when daylighting alone cannot meet the target illumination.

LightSim also reports the “fraction electrical power reduction” if sophisticated controls were able to turn off or dim a portion of the lights, to meet the target illumination.

Reference website for purchase: <https://syngient.in>

## REFERENCES

1. ASRAE Guideline 14-2002, Measurement of Energy and Demand Savings
2. ASRAE Guideline 14-2002, Measurement of Energy and Demand Savings
3. Association for Development and Research of Sustainable Habitats, (2012), The National Rating System for Green Buildings, Ministry of New and Renewable Energy, Government of India.
4. Central Electricity Authority, (2017), Power Sector Profile, Government of India.
5. Chief Sustainability Officer's forum & The Energy Research Institute, (2013), Road map for incorporating Energy Efficiency. Retrofit in Existing Building, TERI.
6. Craig Simmons, (2014), Carbon Handbook: Reducing the carbon footprint of world class events, Moscow.
7. Department of Energy (2003), Industrial Heat Pumps for Steam and Fuel Savings, Washington, DC.
8. Fawzi Behmann, Kwok Wu, (2015), Collaborative Internet Of Things (C-IOT), John Wiley & Sons Ltd, United Kingdom.
9. Hydraulic Institute, (2004) Variable Speed Pumping - A Guide To Successful Applications, U.S. Department of Energy Industrial Technologies Program, Washington, D.C.
10. International Performance Measurement and Verification Protocol; Concepts and Options for determining Energy and Water Savings; Volume 1; Jan 2012; Efficiency Valuation organization
11. International Performance Measurement and Verification Protocol; Concepts and Options for determining Energy and Water Savings; Volume 1; Jan 2012; Efficiency Valuation organization
12. IS/ISO 19011:2011 Guidelines for Auditing Management Systems
13. IS/ISO 19011:2011 Guidelines for Auditing Management Systems
14. IS/ISO 50001:2011 Energy Management Systems- Requirements with guidance for use
15. IS/ISO 50001:2011 Energy Management Systems- Requirements with guidance for use
16. IS/ISO 50001:2018 Energy Management Systems- Requirements with guidance for use
17. IS/ISO 50001:2018 Energy Management Systems- Requirements with guidance for use
18. IS/ISO 9000:2005 QMS – Fundamental and Vocabulary
19. IS/ISO 9000:2005 QMS – Fundamental and Vocabulary
20. ISO 50004:2014 Energy management systems—Guidance for the implementation, maintenance and improvement of an energy management system
21. ISO 50004:2014 Energy management systems—Guidance for the implementation, maintenance and improvement of an energy management system
22. ISO 50006:2014 Energy management systems—Measuring Energy Performance using Energy Baselines (EnB) and Energy Performance Indicators (EnPIs)—General principles and guidance
23. ISO 50006:2014 Energy management systems—Measuring Energy Performance using Energy Baselines (EnB) and Energy Performance Indicators (EnPIs)—General principles and guidance
24. ISO 50015:2014 Energy management systems—Measurement and Verification of energy performance of organizations - General principles and guidance
25. ISO 50015:2014 Energy management systems—Measurement and Verification of energy performance of organizations - General principles and guidance
26. ISO/IEC 17021, Second Edition 2011–02-01, Conformity Assessment – Requirements for bodies providing audit and certification for management systems



27. ISO/IEC 17021, Second Edition 2011–02-01, Conformity Assessment – Requirements for bodies providing audit and certification for management systems
28. ISO\_50001energy.pdf published by ISO
29. ISO\_50001energy.pdf published by ISO
30. JA Clarke, (2001), Energy Simulation in Building Design, Butter Worth Heinemann.
31. John Randolph and Gilbert M Masters, (2008), Energy for Sustainability Technology, Planning, Policy, Island Press.
32. M&V Guidelines: Measurement and Verification for Federal Energy Projects; Version 3.0; FEMP; U.S. Department of Energy
33. M&V Guidelines: Measurement and Verification for Federal Energy Projects; Version 3.0; FEMP; U.S. Department of Energy
34. Ministry of Urban Development, (2015), Smart Cities, Government of India.
35. New Energy & Industrial Technology Development Organization, (2008), Japanese Technologies for Energy Savings/GHG Emissions Reduction, Japan.
36. Sanjay Seth, (2011), BEE Star rating for buildings - An initiative to promote energy efficiency in buildings.
37. Shakti Sustainable Energy Foundation & Indian Smart Grid forum, ( 2017 ) , Smart Grid Handbook for Regulators and Policy Makers.
38. Stephen Dixon, TDS Dixon Inc. and Doug Tripp, (2011), DME Energy Auditing Course Trainer's Guidebook, SADC Industrial Energy Management Project.
39. Stephen Wiel & James E McMohan, (2005), Energy Efficiency Labels and Standards – A Guidebook for appliances Equipment and Lighting, Washington, DC.
40. Steven Fawkes, Kit Oung, David Thorpe, (2016), Best Practices and Case Studies for Industrial Energy Efficiency Improvement, Copenhagen Centre on Energy Efficiency, Denmark.
41. TATA Strategic Management Group, (2014), Energy Efficiency in India: PAT Scheme - The Way Ahead, Tata Strategic Management Group.
42. The Australasian Energy Performance Contracting Association, (2004), A Best Practice Guide to Measurement and Verification of Energy Savings, Commonwealth of Australia.
43. The Indian Green Building Council, (2014), Green New Buildings Rating Systems, Indian Green Building Council, Hyderabad.
44. World Energy Council, (2016), World Energy Resources, Hans-Wilhelm Schiffer.

## WEBSITES

[www.nzeb.in](http://www.nzeb.in)  
<https://www.nrcan.gc.ca>  
<https://www.powermin.nic.in>  
<https://mnre.gov.in>  
<http://www.beeindia.gov.in>  
[www.iso.org](http://www.iso.org)  
[www.energymanagertraining.com](http://www.energymanagertraining.com)  
[www.bee-india.nic.in](http://www.bee-india.nic.in)  
[www.enms-doc.com](http://www.enms-doc.com)  
[www.iaf.nu](http://www.iaf.nu)  
<https://www.coal.nic.in>  
[petroleum.nic.in/](http://petroleum.nic.in/)





